

AquaCal® Installation Manual

WATER SOURCE

SWIMMING POOL AND SPA HEAT PUMPS AND

SUNPOWER



Important

Read this document before operating / installing this product

For additional product manuals and operation / installation procedures, please visit www.AquaCal.com

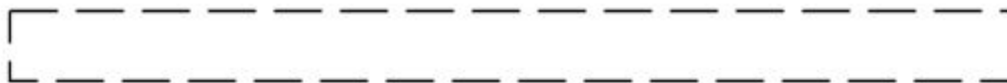

MODEL

/

SERIAL NUMBER

Table of Contents

Contacting AquaCal AutoPilot, Inc.	1
Safety Instructions	1
1 - Installation	3
1.1 Dimensions	3
1.2 Positioning Equipment	4
1.3 Clearances	5
1.4 Plumbing	6
1.4.a Plumbing Requirements	6
1.4.b Water Source Plumbing Diagrams	7
1.4.c SunPower Plumbing Diagrams	10
1.4.d Water Connections to Heat Pump	11
1.4.e In-Line Chlorine Feeders	13
1.4.f Water Flow Rates	14
1.4.g Adjusting Water Flow Using ΔT (Delta-T)	15
1.4.h Maintaining Ability to Winterize	16
1.4.i Adjusting Water Pressure Switch	16
1.5 Electrical	17
1.5.a Electrical Requirements	17
1.5.b Incoming Power Access Holes	20
1.5.c Access Panels	21
1.5.d Verifying Transformer Setting	21
1.5.e Three-Phase Adjustment	22
1.5.f Schematics	22
1.5.g Connecting an External Controller	23
1.5.h Programming for an External Controller	24
1.6 Service Level Programming	26
1.6.a Service Level Factory Defaults	26
1.6.b Enter Service Level Programming	27
1.7 Cleaning Equipment After Installation	29
2 - Operation	31
2.1 Energizing Heat Pump	31
2.2 Wake Up Heat Pump	31
2.3 Display Panel	31
2.3.a Buttons	31
2.3.b Display	31
2.3.c Indicator Lights	32
2.4 User Level Programming	32

2.4.a User Level Factory Defaults	32
2.4.b Selecting Celsius or Fahrenheit	34
2.4.c Setting Operating Mode	34
2.4.d Setting Thermostats	35
2.4.e User Lock Option (Enable)	35
2.4.f User Lock Option (Disable)	36
2.4.g Using Pass Code to Access Heat Pump	36
2.4.h Operating Heat Pump (With an External Controller)	37
3 - Maintenance	38
3.1 Water Chemistry	38
3.2 Planned Maintenance	38
3.3 Winterizing	39
4 - Appendix	42
4.1 Identifying Model Specifications	42
4.2 Weights	43
4.3 Heating Recommendations	43
4.4 Cooling Recommendations	43
4.5 Available Accessories	44
4.6 Schematics	46
Schematic LTM0196	47
Schematic LTM0739	48
Schematic LTM0738	49
Schematic LTM0738	50
Schematic LTM0739	51
5 - Troubleshooting	52
5.1 Fault Codes	52
5.2 Issues and Resolutions	55

Contacting AquaCal AutoPilot, Inc.

For further assistance, please contact the distributor or installer of this product.

If unavailable, please contact AquaCal® for a partner in your area. To better assist you, please have the heat pump model and serial number available. See "Identifying Model Specifications" on page 42.



Product Information:	
Website	www.AquaCal.com
Phone	(1) 727-823-5642
Hours	8-5 pm, Eastern M-F

Service Information:	
Website	www.AquaCal.com/request-heat-pump-service/

SAFETY INSTRUCTIONS

- For personal safety, and to avoid damage to equipment, follow all safety instructions displayed on the equipment and within this manual. Repair and service of heat pump must be performed by an authorized service center.
- Warranties may be voided if the equipment has been improperly installed, maintained or serviced.
- If service is deemed necessary, please see "Contacting AquaCal AutoPilot, Inc." on page 1.

SAFETY SIGNALS
Throughout this document, safety signals have been placed where particular attention is required.

	- Failure to heed the following will result in injury or death.
	Failure to heed the following may result in injury or death.
	Failure to heed the following may result in damage to equipment.

When installing and using your heat pump basic safety precautions must always be followed, including the following:

- | | |
|---|--|
|  | - Failure to heed the following will result in injury or death. |
| | <ul style="list-style-type: none"> • The heat pump utilizes high voltage. Use caution when servicing. |

⚠ WARNING

Failure to heed the following may result in injury or death.

- Installation and repairs must be performed by a qualified technician.
- The heat pump contains refrigerant under pressure. Repairs to the refrigerant circuit must not be attempted by untrained and / or unqualified individuals. Service must be performed only by qualified HVAC technicians. Recover refrigerant before opening the system.
- Improper water chemistry can present a serious health hazard. To avoid possible hazards, maintain pool / spa water per standards detailed in this document.
- Prolonged immersion in water warmer than normal body temperature may cause a condition known as Hyperthermia. The symptoms of Hyperthermia include unawareness of impending hazard, failure to perceive heat, failure to recognize the need to exit the spa, and unconsciousness. The use of alcohol, drugs, or medication can greatly increase the risk of fatal Hyperthermia. In addition, persons having an adverse medical history, or pregnant women, should consult a physician before using a hot tub or spa. Children and the elderly should be supervised by a responsible adult.
- Prolonged immersion in water colder than normal body temperature may cause a condition known as Hypothermia. The symptoms of Hypothermia include shivering (although as hypothermia worsens, shivering stops), clumsiness or lack of coordination, slurred speech or mumbling, confusion and poor decision-making, drowsiness or low energy, lack of concern about personal welfare, progressive loss of consciousness, weak pulse and slow or shallow breathing. In addition, persons having an adverse medical history, or pregnant women, should consult a physician before immersing in a cold body of water. Children and the elderly should be supervised by a responsible adult.

NOTICE

Failure to heed the following may result in damage to equipment.

- Maintain proper water chemistry in order to avoid damage to pump, filter, pool shell, etc.
- Water flow exceeding maximum flow rate requires a bypass. Damage due to excessive water flow will void warranty.

SAVE THESE INSTRUCTIONS

1 - Installation

WARNING

Failure to heed the following may result in injury or death.

- Installation of this equipment by anyone other than a qualified installer can result in a safety hazard.
- The information contained throughout the "Installation" section is intended for use by qualified installation technicians familiar with the swimming Pool / Spa safety standards.

NOTICE

Failure to heed the following may result in damage to equipment.

- Failure to protect equipment against corrosive conditions will adversely affect the life of the equipment and will void equipment warranty.

1.1 Dimensions

(Water Source WS03, WS05)

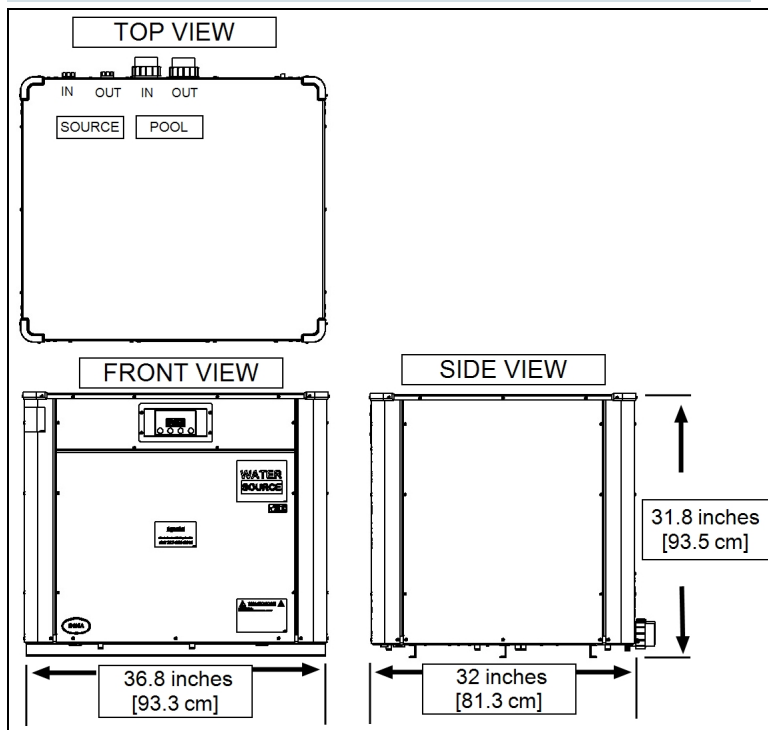

(Water Source WS10)

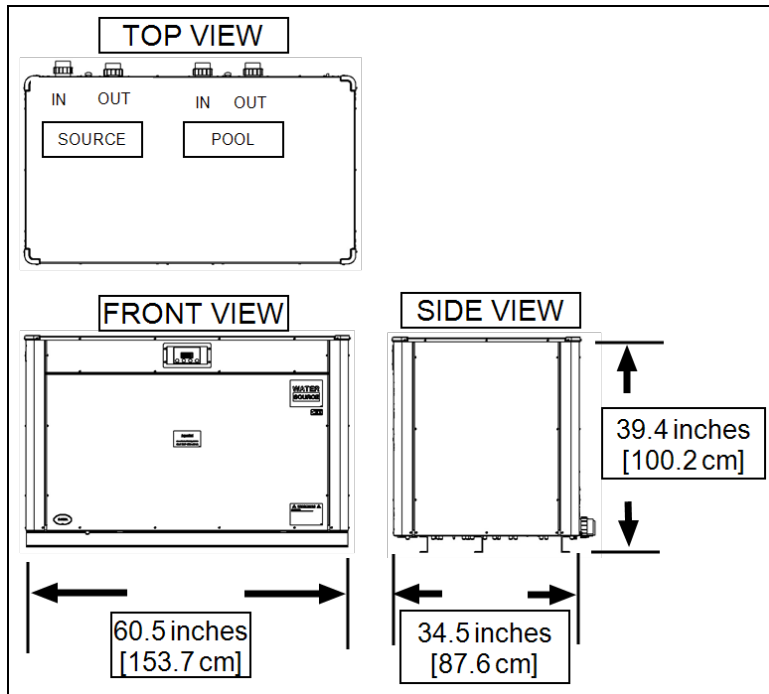

(SunPower SP05)

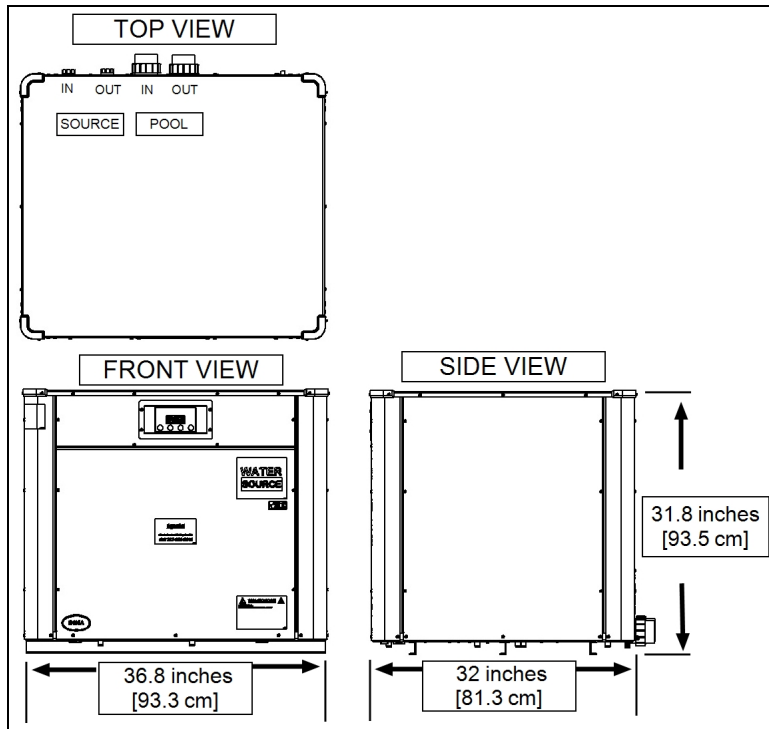

1.2 Positioning Equipment

Controlling Irrigation and Rainwater Runoff

- Irrigation water may damage heat pump components. Direct irrigation water away from the heat pump.
- The heat pump will withstand normal rainfall. Do not allow a roof slope to direct rainwater onto the heat pump. Have a gutter installed on the roof edge to direct this water away from the heat pump. Or install the heat pump in another location.

Mounting Pad Requirements

- Build the heat pump pad out of concrete or other code-approved material.
- Confirm the pad can support the weight of the heat pump. See "Weights" on page 43.
- Elevate the pad enough to allow for drainage.
- Make sure the pad is flat and level.
- Have the pad extend at least 6 inches from the heat pump base in all directions.
- Do not install the heat pump on soil or grass.
- Do not allow the heat pump base to touch the building's foundation.
- Do not place the heat pump directly on a concrete floor. This can cause noise to be transmitted to an occupied space. If necessary install vibration dampers between the heat pump base and floor.
- Equipment pad must meet all requirements of authorities having code-related jurisdiction.

Anchoring to Pad

- Follow all applicable local, state, and national requirements regarding wind load anchoring.
- The shipping brackets used to secure the heat pump to the pallet are approved mounting (hurricane) brackets. They should be used to anchor the heat pump to the pad.
- If needed, contact AquaCal® to obtain anchoring kit information. Please have the heat pump model number and serial number when requesting support. See "Identifying Model Specifications" on page 42.

1.3 Clearances

- Locate the heat pump at least 24 inches away from the wall. And provide a minimum 24 inches between heat pumps. This will allow for rear plumbing access and electrical connections.
- Do not stack heat pumps on top of each other. Use approved racks when stacking equipment.
- Only rack equipment two units high.
- Equipment rack must meet all requirements of authorities having code-related jurisdiction.
- Avoid storing chemical containers near the heat pump. The chemicals can cause equipment damage.
- Avoid placing objects near or on top of the heat pump. This includes shrubbery and lawn furniture. These objects will reduce performance and efficiency and hinder maintenance access.

Water Source (Top View)

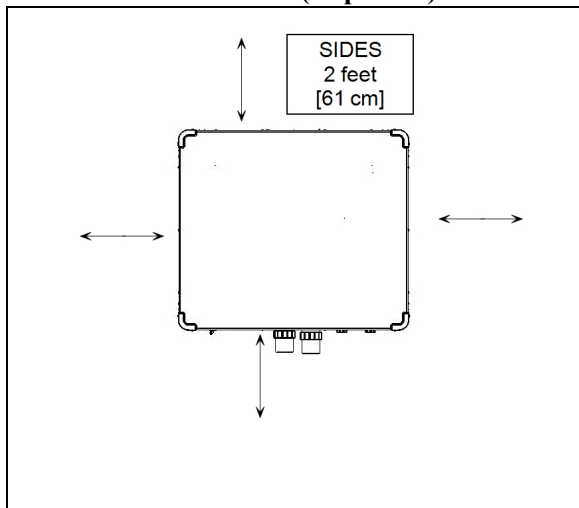

Water Source (Side View)

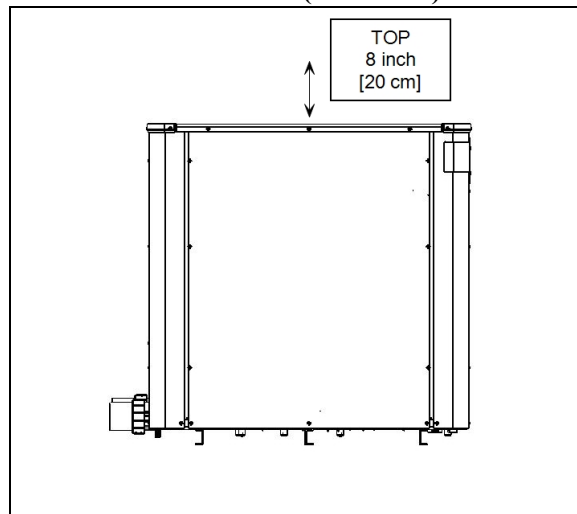

1.4 Plumbing

1.4.a Plumbing Requirements

NOTICE

Failure to heed the following may result in damage to equipment.

- Do not use glue on the threaded portion of the equipment's unions. A glued-in-place union will prevent the equipment from being properly winterized.
- The heat pump must receive water flow within the specified minimum ranges under worst-case conditions such as a fouled water filter.
- Failure to provide clean filtered water to the heat pump can void product warranty.
- Water flow exceeding maximum flow rates will negatively affect the total pool filtration performance and may damage the heat pump. This will not be covered under equipment warranty. See "Water Flow Rates" on page 14.
- Temperature ports with PVC tees and a test thermometer are also provided in selected models. These ports must be installed between the unions and the bypass valves. The preferred location of the port is 6" from the heat pump union. See "Adjusting Water Flow Using ΔT (Delta-T)" on page 15.
- Using open saltwater applications as the heat pumps source water is not recommended.
 - Saltwater can promote the growth of crustaceans, which can clog a heat pump's heat exchanger. These types of applications are highly problematic and require additional maintenance.
 - If a saltwater source is unavoidable, install an external plate heat exchanger to protect the heat pump from fouling. Please note – Saltwater wells do not require an external plate heat exchanger.

1.4.b Water Source Plumbing Diagrams

Plumbing diagrams are provided in this section as a planning guide to the sequence of equipment, valves, and fittings.

- The basic plumbing configurations for typical installations are shown.
- If the installation does not closely follow any of the supplied plumbing diagrams, AquaCal® Technical Support is available for installation advice and guidance.
- Confirm water provided to heat pump is clean and filtered.

It's important to use contractors familiar with geothermal applications when installing a Water Source heat pump.

Single Water Source Heat Pump Configuration (Standard Pressures)

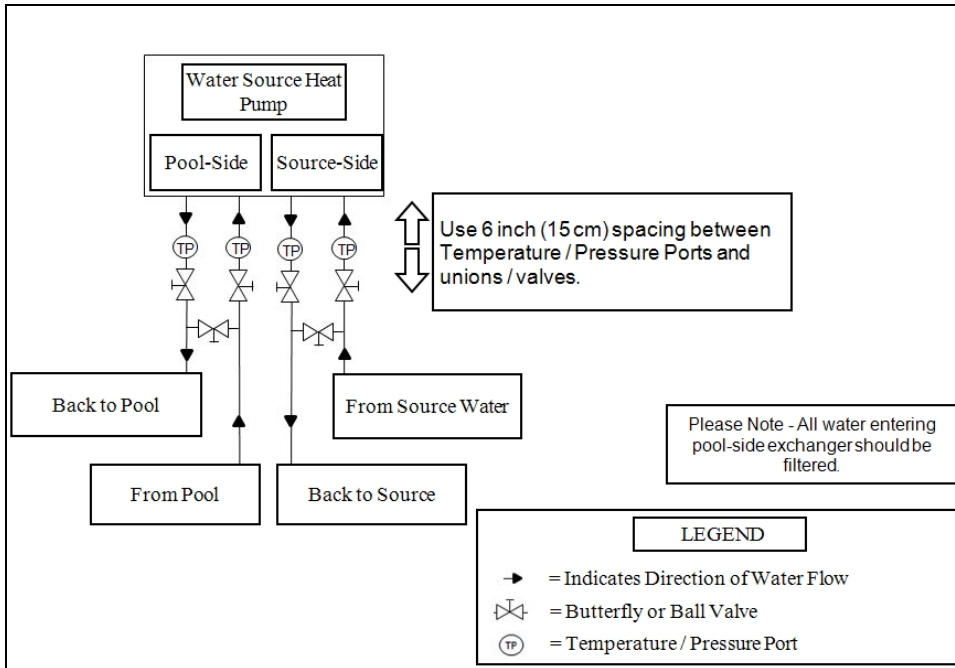

Multiple Water Source Heat Pump Configuration (Standard Pressures)

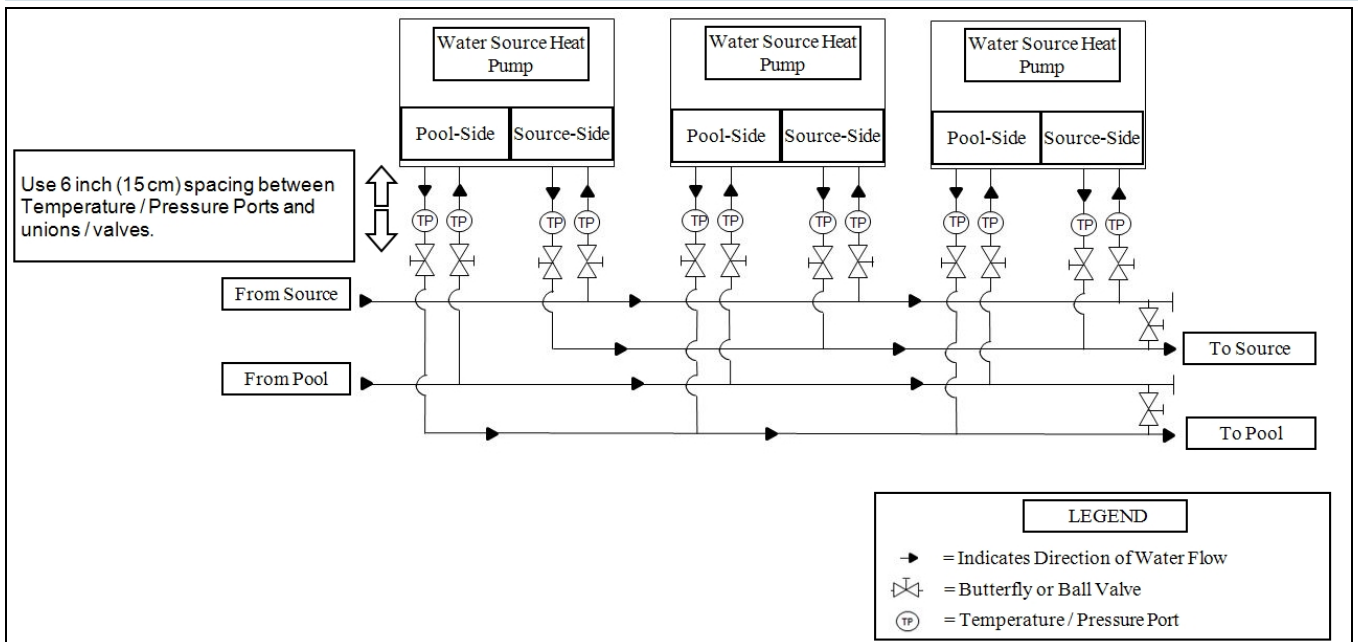

Single Water Source Heat Pump Configuration (High-Pressure)

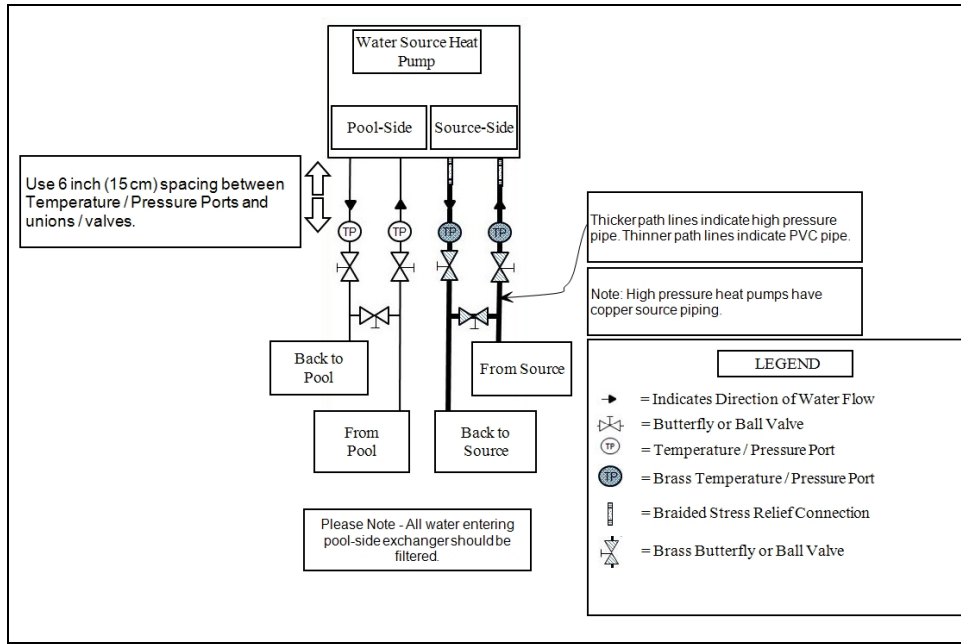

Multiple Water Source Heat Pump Configuration (High-Pressure)

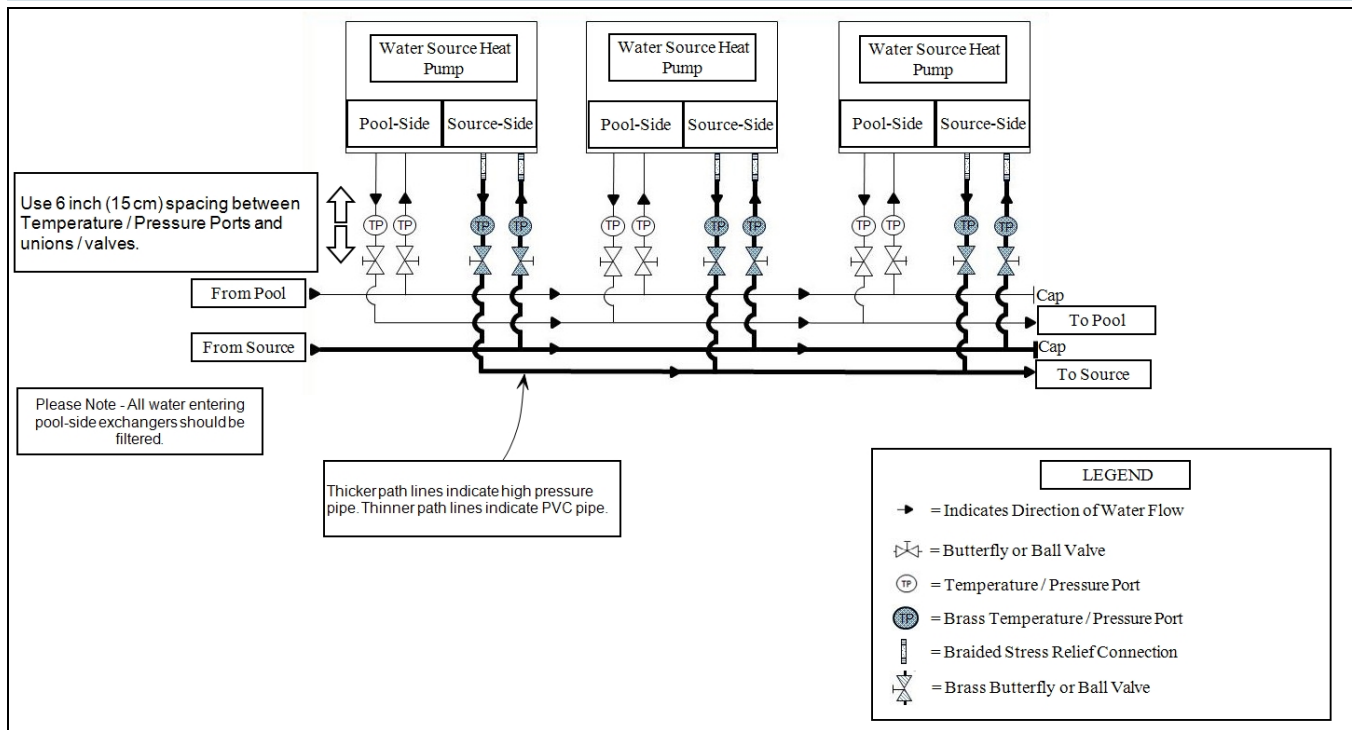

Water Source Heat Pump with Support Equipment

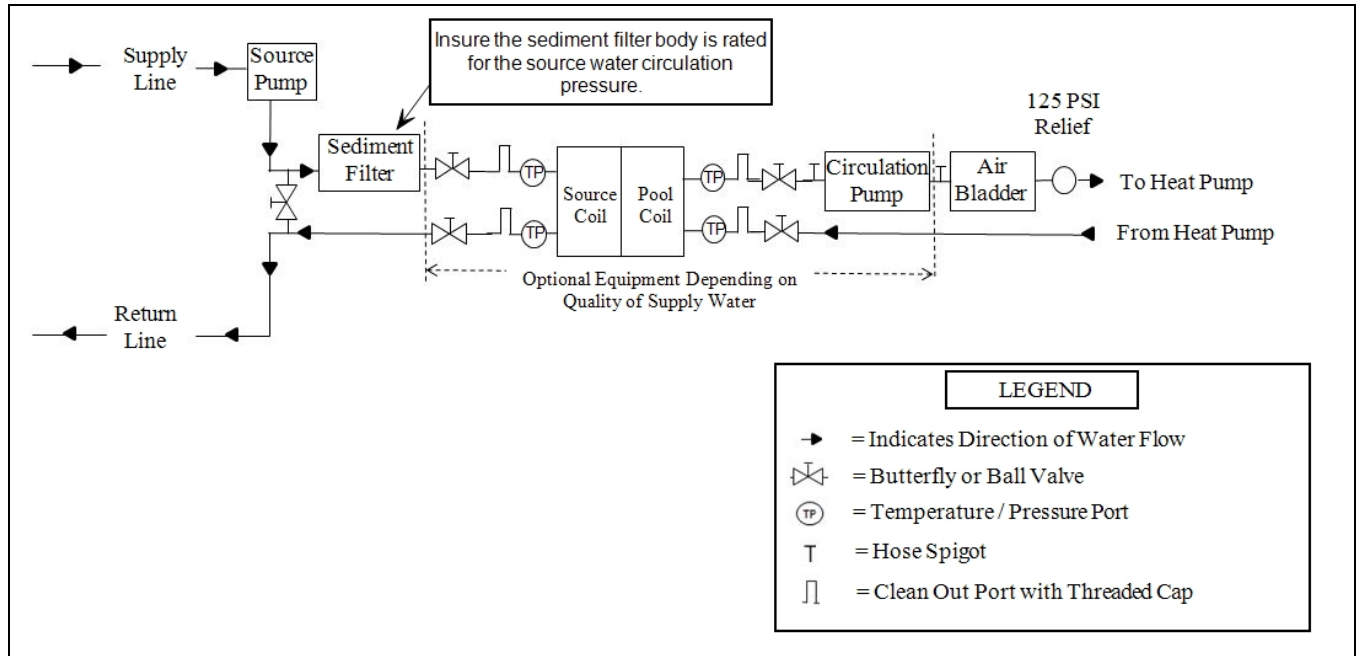

Water Source Heat Pump (Reverse Return Detail)

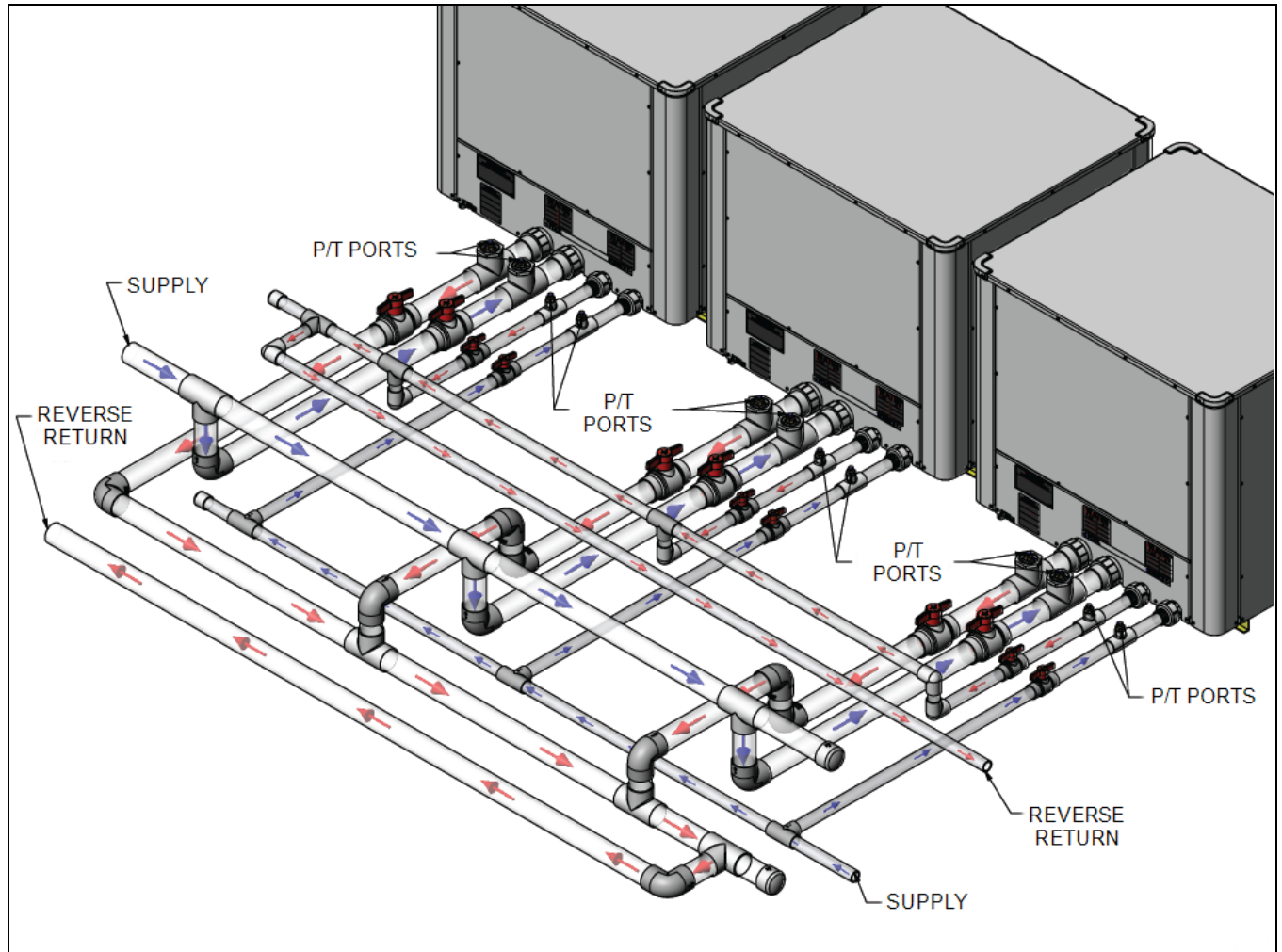

1.4.c SunPower Plumbing Diagrams

Plumbing diagrams are provided in this section as a planning guide to the sequence of equipment, valves, and fittings.

- The basic plumbing configurations for typical installations are shown.
- If the installation does not closely follow any of the supplied plumbing diagrams, AquaCal® Technical Support is available for installation advice and guidance.
- Confirm water provided to heat pump is clean and filtered.

Typical SunPower Installation

Dedicated Spa Heater using Pool as the Heat Source.

PLEASE NOTE -

The SunPower is designed to provide heating for a spa. Not a pool.

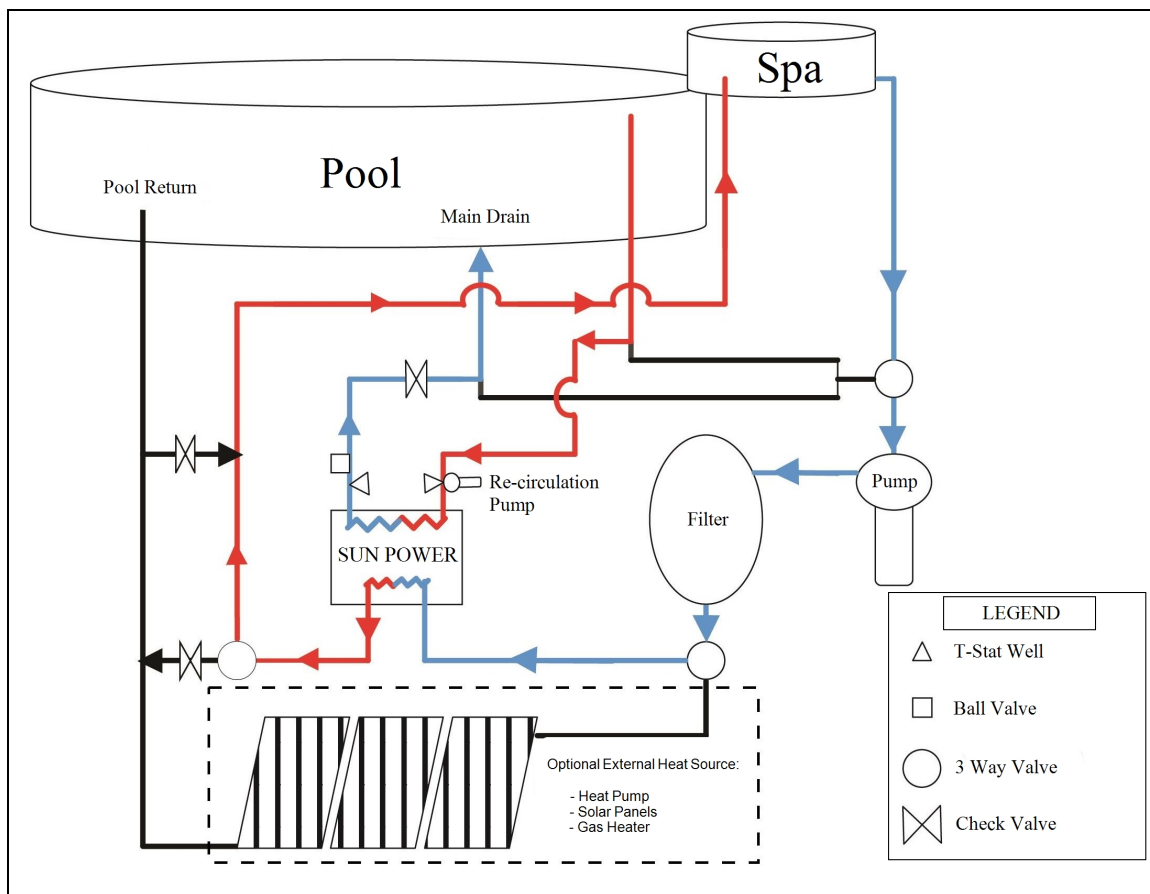

SunPower Heat Pump Configuration

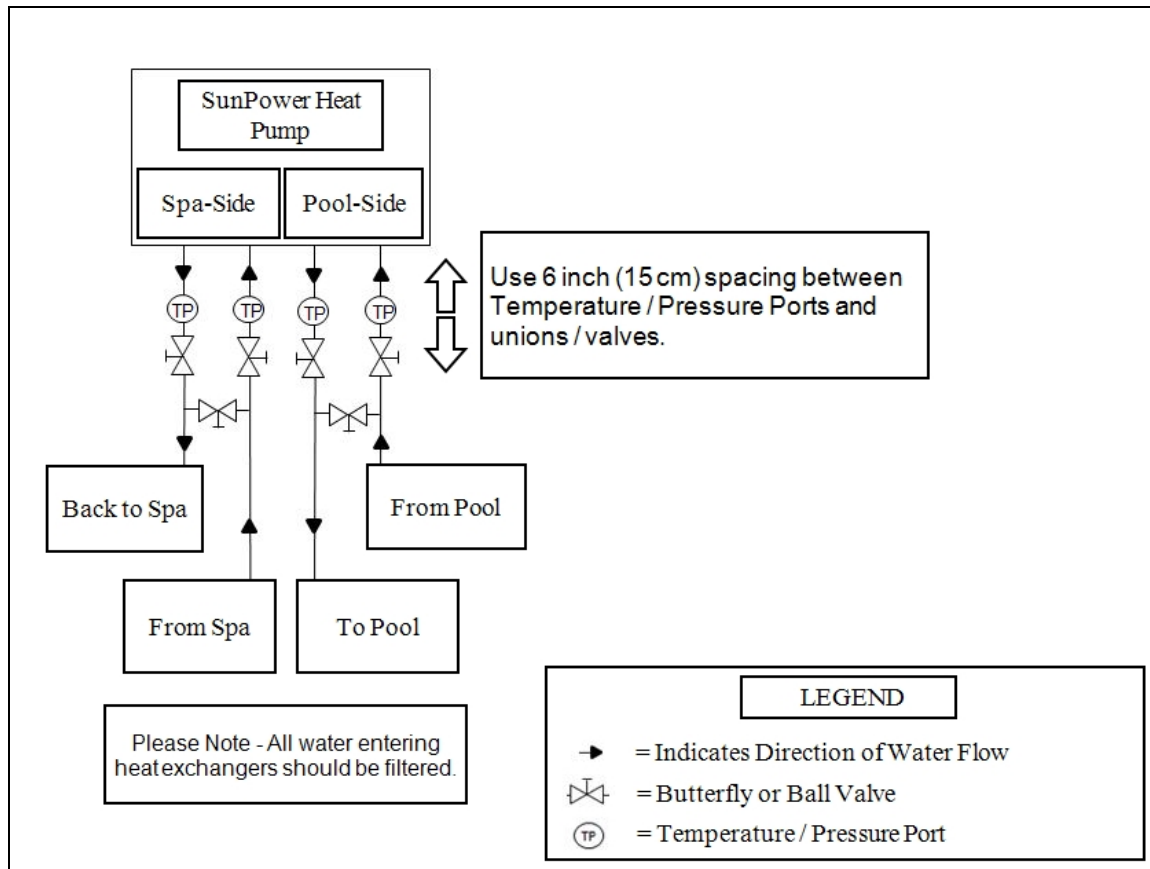

1.4.d Water Connections to Heat Pump

- Heat Pump union sizes are specified on diagrams.
- Connections to site plumbing are made via PVC solvent cement to the female slip socket of the plumbing unions.
- High-pressure units use joint compound on threaded copper connections. See "Single Water Source Heat Pump Configuration (High-Pressure)" on page 8.
- Plumbing unions are available from AquaCal®. See "Available Accessories" on page 44.

NOTICE

Failure to heed the following may result in damage to equipment.

- Do not use glue on the threaded portion of the equipment's unions. A glued-in-place union will prevent the equipment from being properly winterized.

Water Source WS10 (Titanium or Cupronickel Exchanger)

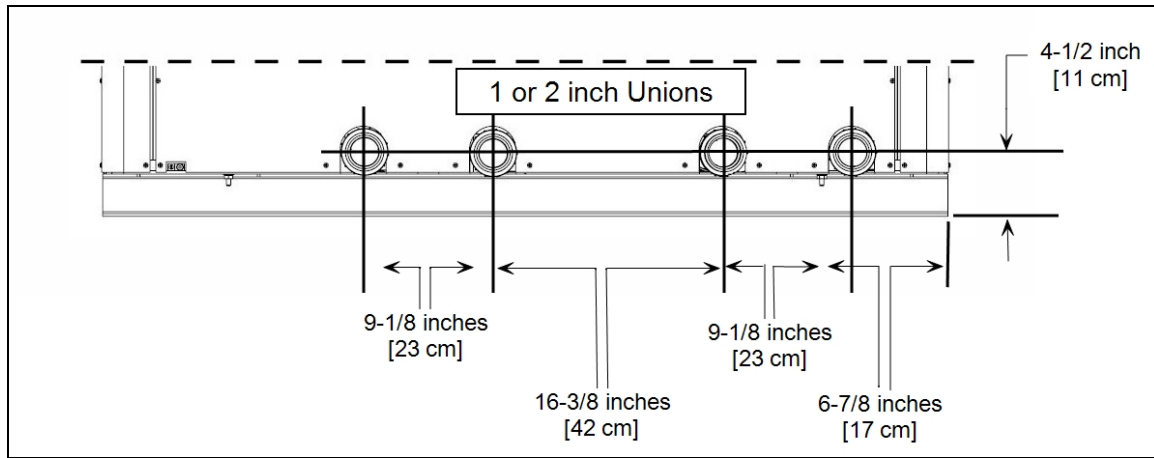

Water Source WS03 and WS05 (Titanium Exchanger Only)

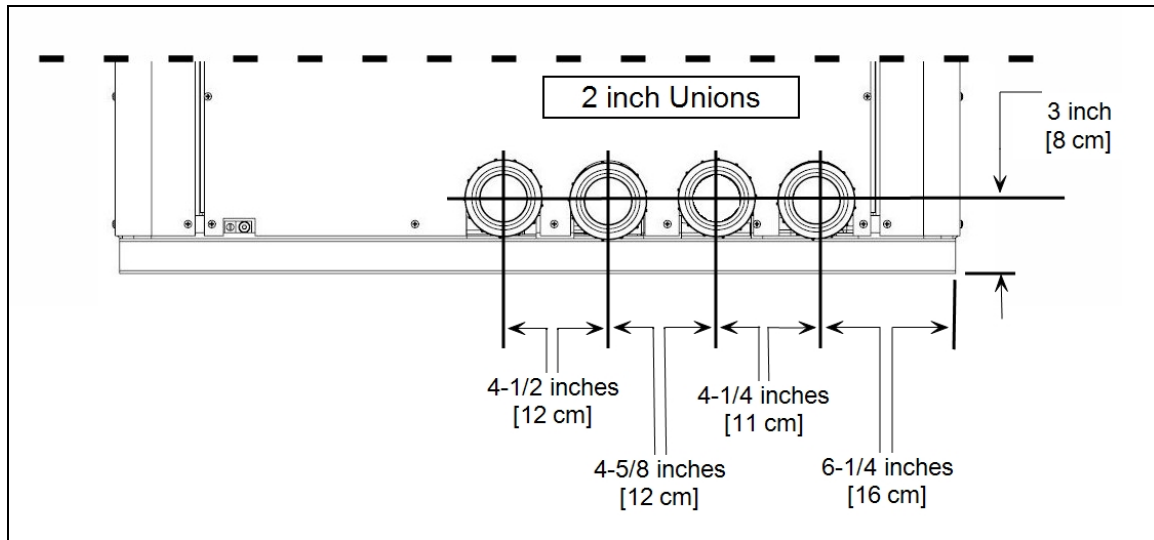

Water Source WS03 and WS05 (Titanium / Cupronickel Exchanger Combination)

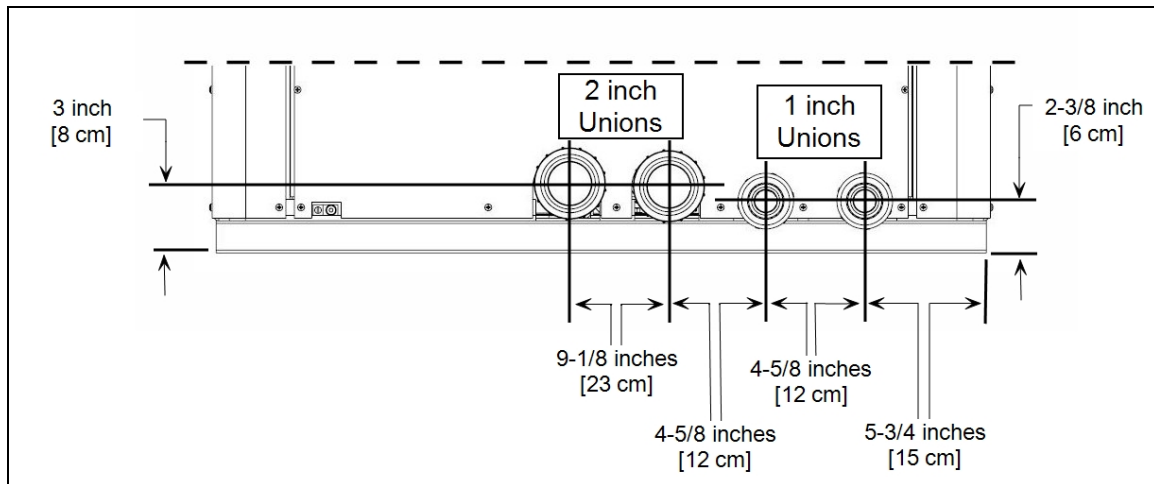

SunPower SP05 (Titanium Exchanger Only)

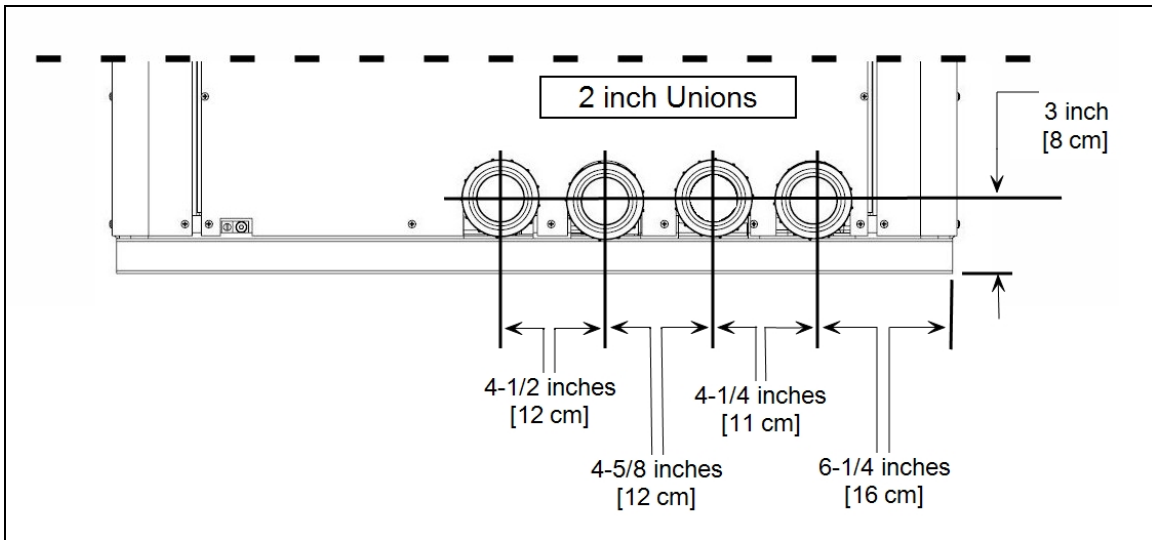

SunPower SP05 (Titanium / Cupronickel Exchanger Combination)

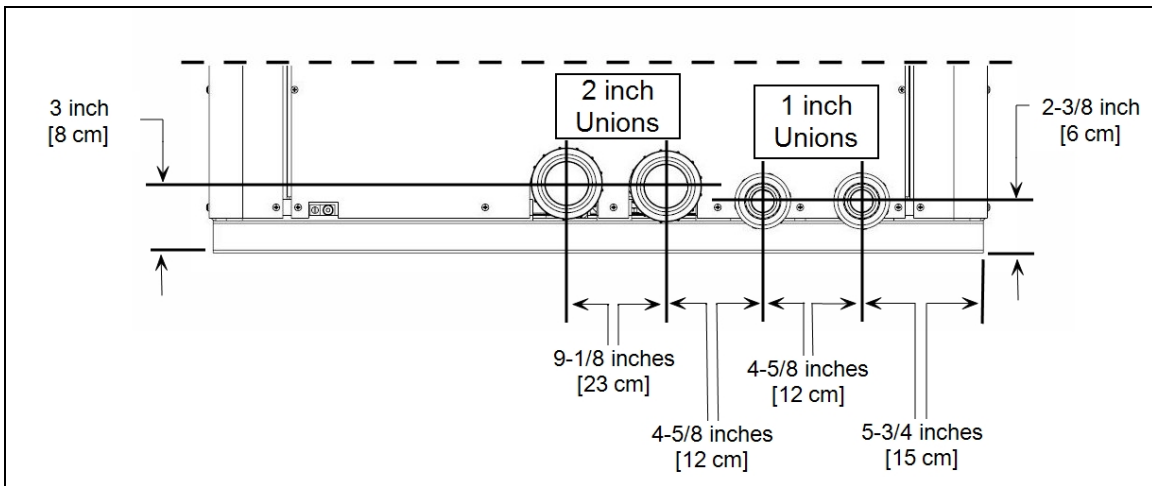

1.4.e In-Line Chlorine Feeders

Place in-line chlorinators downstream from the heat pump and as low in elevation as possible. If an erosion type feeder is used, always install a Hartford Loop to protect internal heat pump components.

Heat Pump with Hartford Loop

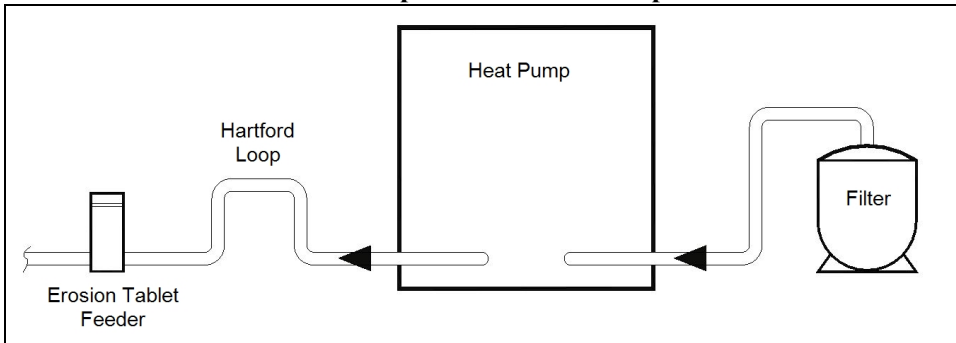

1.4.f Water Flow Rates

Maintain water flow rates as indicated. Please note, these specifications relate to the heat pump only. Code-specified whole system turnover rates must be satisfied.

NOTICE

Failure to heed the following may result in damage to equipment.

- Water flow exceeding maximum flow rates will negatively affect the total pool filtration performance and may damage the heat pump. This will not be covered under equipment warranty.

Water Source

MODEL	SOURCE	HEAT EXCHANGER TYPE	FLOW RATES	
			MINIMUM	MAXIMUM
WS03	Source-Side	Titanium ThermoLink®	20 GPM	70 GPM
		Cupronickel	10 GPM	14 GPM
	Pool / Spa	Titanium ThermoLink®	30 GPM	70 GPM
		Cupronickel	N/A	N/A
WS05	Source-Side	Titanium ThermoLink®	20 GPM	70 GPM
		Cupronickel	10 GPM	18 GPM
	Pool / Spa	Titanium ThermoLink®	30 GPM	70 GPM
		Cupronickel	N/A	N/A
WS10	Source-Side	Titanium ThermoLink®	30 GPM	70 GPM
		Cupronickel	30 GPM	54 GPM
	Pool / Spa	Titanium ThermoLink®	30 GPM	70 GPM
		Cupronickel	N/A	N/A

SunPower

MODEL	SOURCE	HEAT EXCHANGER TYPE	FLOW RATES	
			MINIMUM	MAXIMUM
SP05	Spa-Side	Titanium ThermoLink®	20 GPM	45 GPM
	Pool-Side	Titanium ThermoLink®	30 GPM	70 GPM

PLEASE NOTE -

If minimum flow rates are not met, heat pump performance is reduced and performance will suffer. Internal safety devices may deactivate the heat pump with the following errors:

- **HP** and **HP5**
- or (if equipped) error codes of **LP** and **LP5**

- Operate water filtration devices per manufacturer's specifications. Dirty filters can cause a reduction of water flow to the heat pump. An increase of 7-10 psi higher than the clean filter pressure typically reduces flow rates. This

requires the filter to be cleaned or back-washed.

- Keep baskets free of debris. A large quantity of debris in the pump and skimmer baskets can reduce water flow.
- Check for improper valve settings. A partially closed valve after the filter, or a full-open bypass around the heat pump, will cause insufficient water flow through the heat pump.
- The maximum static pressure (or operating pressure) is 50 pounds-per-square-inch (PSI) unless a special "high-pressure" unit has been ordered. These specifications relate to the heat pump only.
- Code-specified whole system turnover rates must be satisfied.

1.4.g Adjusting Water Flow Using ΔT (Delta-T)

The Delta-T is the temperature difference between the water temperatures entering and leaving the heat pump. The equipment can be fine-tuned for maximum performance by balancing water flow rates to maintain an ideal ΔT .

- Installed temperature ports are required to perform the following procedures.
- **This adjustment procedure must be completed with the unit in heating mode.**

PLEASE NOTE -

- The installation of temperature ports are required for all Water Source and SunPower heat pumps on both inlet and outlet piping.
- See "Temperature Port Kit" on page 45.

1. Adjust thermostat to its lowest setting with unit in heating mode.
2. Deactivate the water filtration pump.
3. Confirm that the filters leading to the heat pump are clean.
4. Adjust the valves controlling water headed towards the heat pump to the half open position.
5. Adjust the valves controlling water leading away from the heat pump to a fully open position.
6. Activate the pool water filtration pump.
7. Slowly raise the thermostat temperature until the heat pump activates.
 - The source-water filtration pump will cycle on first.
 - After a four-minute delay, the heat pump's compressor will start.
8. With the heat pump running, confirm the source-side water filtration pump is operating properly with adequate flow and no short cycling.
9. Wait for water temperatures to stabilize (approximately 5 minutes).
10. Adjust valves in the following order:
 - a. Adjust the source-side valve that controls water exiting the heat pump. Match the temperature measured with a temperature probe to the temperature chart.
 - b. Adjust the pool-side valve that controls water exiting the heat pump. Match the temperature measured with a temperature probe to the chart. (See "Temperature Chart" in this section)
 - c. Wait for water temperatures to stabilize. Then check source-side temperature again. Re-adjust the valve controlling the water exiting the heat pump as needed.
 - d. Wait for water temperatures to stabilize. Then check pool-side temperature again. Re-adjust the valve controlling the water exiting the heat pump as needed.
11. Mark valves at these positions for future reference.

**Temperature Port
(Shown with Probe)**

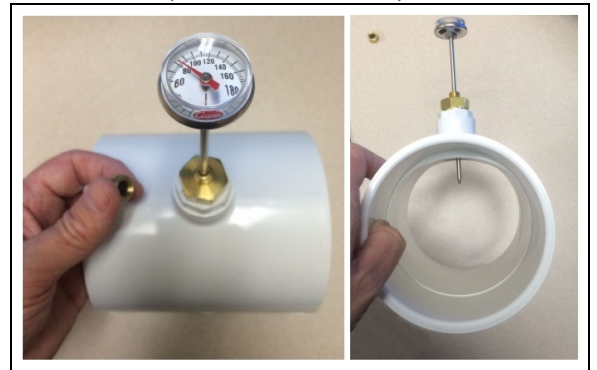

HEAT EXCHANGER TYPE	MODEL	POOL-SIDE	SOURCE-SIDE
Titanium pool-side and source-side exchangers	WS03	2° to 4° F	1° to 5° F
	WS05	3° to 6° F	2° to 8° F
	WS10	6° to 14° F	5° to 12° F
Titanium pool-side exchanger and cupronickel source-side exchanger	WS03	1° to 3° F	6° to 8° F
	WS05	2° to 6° F	7° to 13° F
	WS10	6° to 14° F	6° to 11° F
Titanium ThermoLink®	SP05	3° to 6° F	2° to 8° F

Table 1 - Temperature Chart

PLEASE NOTE -

- Temperature differences are based on pool and source water temperatures of 69° to 75° F.
- For water temperatures outside this range, contact AquaCal®. See "Contacting AquaCal AutoPilot, Inc." on page 1.

1.4.h Maintaining Ability to Winterize

Do not glue the threaded portion of the unions. The unions are used to decouple the heat pump from the plumbing system during hard freeze conditions.

NOTICE

Failure to heed the following may result in damage to equipment.

- Do not use glue on the threaded portion of the equipment's unions. A glued-in-place union will prevent the heat pump from being properly winterized.

1.4.i Adjusting Water Pressure Switch

Adjust water pressure switch when heat pump attempts to operate without water flow.

Before attempting any adjustments confirm the following :

- The filter is clean.
- Filter pump is operating.
- The valves are set to direct the appropriate amount of water through the heat pump. See "Water Flow Rates" on page 14.
- **FLD** is displayed (or displays intermittently).

WARNING

Failure to heed the following may result in injury or death.

- Water Pressure Switch adjustment procedure to be performed by experienced service personnel only; procedure must not be attempted by individuals lacking adequate electrical and mechanical experience.

NOTICE

Failure to heed the following may result in damage to equipment.

- If after water pressure switch adjustment the heat pump continues to operate with the filter pump off, readjust water pressure switch to ensure heat pump will not run without water flow.
1. Remove heat pump access panel. See "Access Panels" on page 21.
 2. Locate the water pressure switch. It will be outside and along the bottom edge of the electrical enclosure. Exact location varies by model.
 3. Activate filter pump.
 4. Apply power to heat pump.
 5. Slowly rotate the adjustment wheel on the switch. Keep turning the wheel until the heat pump indicates it is receiving water. The display will no longer display the **FLD** code.
 6. Deactivate filter pump. If correctly adjusted, the heat pump will deactivate and the display will show the **FLD** code.
 7. Re-install heat pump access panel.
 - If heat pump continues to operate without water flow, contact AquaCal®.
 - Site-specific factors may require the installation of an external flow switch. See "Available Accessories" on page 44.

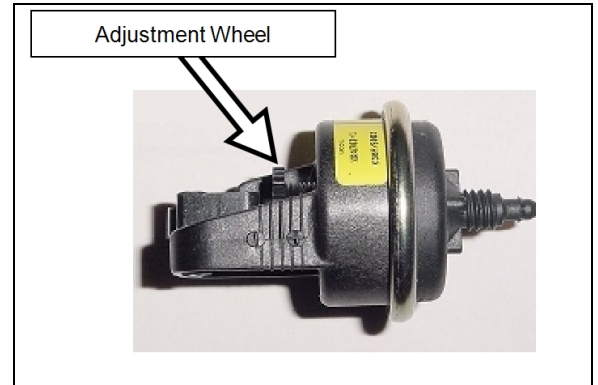

1.5 Electrical

1.5.a Electrical Requirements

⚠ WARNING

Failure to heed the following may result in injury or death.

- The information contained in this section is intended for use by qualified electricians familiar with electrical service-industry safety standards and methods.
- Locate the equipment disconnect as near to the heat pump as possible. Always satisfy applicable codes and standards.
- Never mount power-disconnects directly to the heat pump.
- In sizing power wiring, be especially aware of up-sizing requirements necessary due to wiring distances. Always satisfy applicable codes and standards.
- AquaCal® heat pumps are designed to use copper conductors, only. Do not use aluminum wire.
- Multiple heat pumps installed at the same site may benefit from automatic sequencing controllers (ASC) to avoid excessive power drops at start-up. See "Available Accessories" on page 44.

Electrical Standards

Standards	Title
NFPA 70	The electrical installation must conform to the current version of the NEC, and all applicable local and state codes
NFPA 70 Article 440	Standard for Safety for Electric Spas, Equipment Assemblies, and Associated Equipment
NFPA 70 Article 680	Standard for Safety for Swimming Pool Pumps, Filters, and Chlorinators
IEC 60335-1-2001	Household and similar electrical appliances - Safety - General Requirements
IEC 60335-2-40 2006	Household and similar electrical appliances - Safety – Particular requirements for electrical heat pumps, air-conditioners, and dehumidifiers
UL1995 & CSA C22.2 236-05	Heating and cooling equipment

Table 2 - Standards

Grounding and Bonding

Follow local code requirements for properly grounding and bonding heat pump equipment.

- A bonding lug has been provided on the lower left hand corner of the plumbing access panel.

Surge Suppression

The use of approved commercial surge protectors is strongly recommended.

Sizing the Electrical Service

Refer to equipment data plate for specific information required to size electrical service and over-current protection of heat pump. Sizing is based on data plate information, wire size, wiring devices, and over-current protection per applicable local codes and standards. See "Identifying Model Specifications" on page 42.

Minimum and Maximum Operating Voltage

The heat pump must operate within specified voltages.

NOTICE

Failure to heed the following may result in damage to equipment.

- Operating equipment under higher or lower voltage conditions may result in damage to your compressor, motors or other electrical components. This damage will not be covered by product warranty.
1. Measure site voltage. The site voltage **MUST** be measured under “FULL LOAD” conditions. Activate all equipment using the same electrical panel as the heat pump.
 2. If measured site voltage is outside listed ranges, immediately deactivate equipment until site conditions have been corrected. If unsure of heat pump equipment rating, please see "Identifying Model Specifications" on page 42.

Equipment Rating	Minimum Site Voltage	Maximum Site Voltage
A Voltage (208 to 230 Volts) Single Phase 60 hertz	200 Volts	253 Volts
B Voltage (208 to 230 Volts) 3 phase 60 hertz	200 Volts	253 Volts
G Voltage (460 Volts) 3 phase 60 hertz	437 Volts	483 Volts
H Voltage (200 to 240 Volts) Single Phase 50 hertz	180 Volts	264 Volts

PLEASE NOTE

The WS10 Water Source heat pump comes with an ICM phase-rotation monitor. All other three-phase models use the standard phase-rotation monitor. These monitors are located inside the electrical panel.

The device protects the heat pump by preventing operation during abnormal voltage conditions.

- If the unit fails to operate, a qualified technician should check the phase rotation monitor for faults preventing operation. Complete instructions for the ICM phase monitor are in the appendix. See "ICM Digital 3-Phase Monitor"

**ICM Digital
Three-Phase
Monitor**



**Standard
Three-Phase
Monitor**

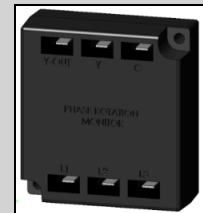

1.5.b Incoming Power Access Holes

Water Source WS03, WS05 SunPower SP050

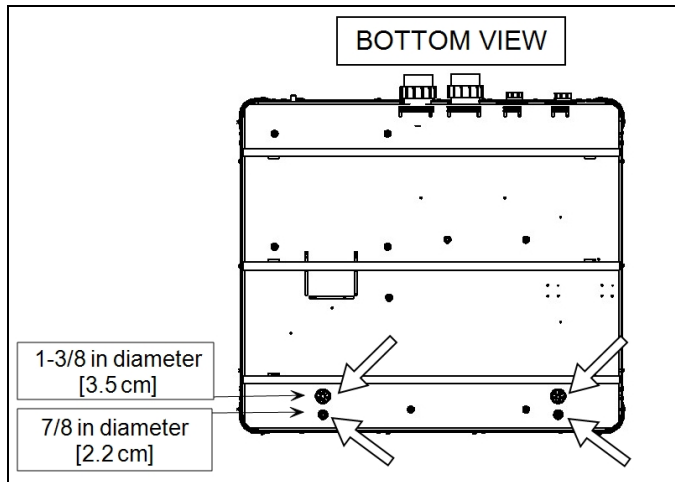

Water Source WS10

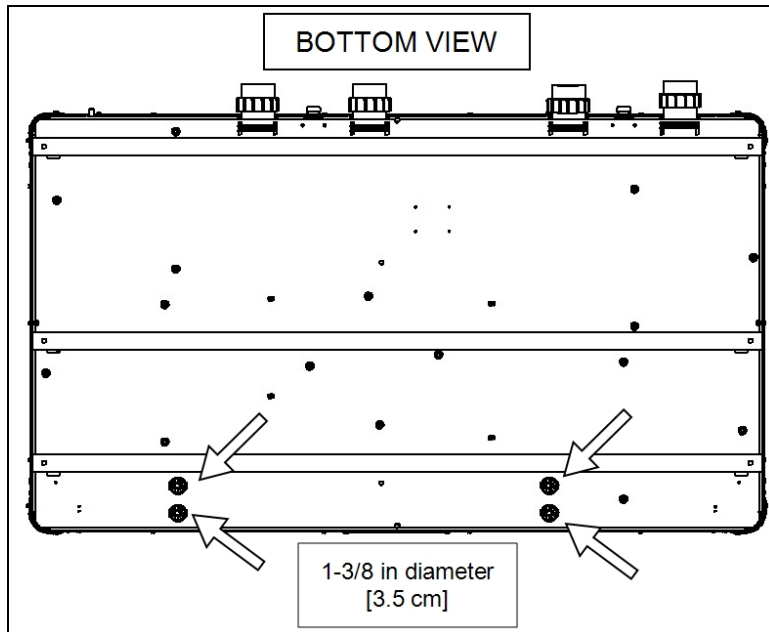

1.5.c Access Panels

(SunPower)

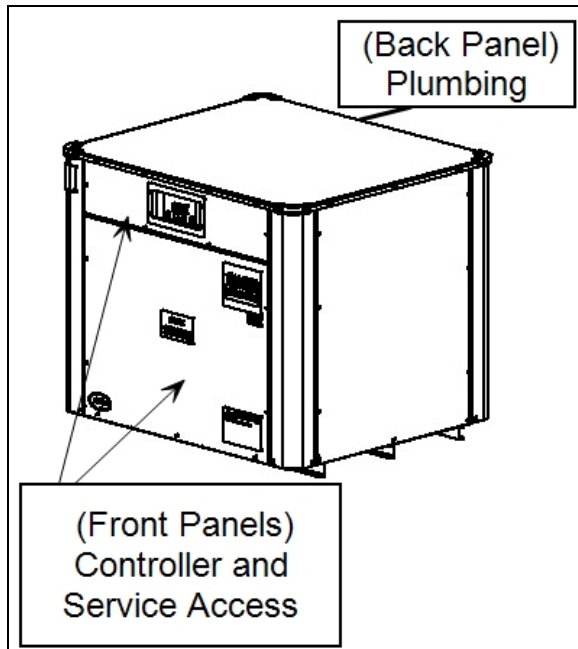

(Water Source)

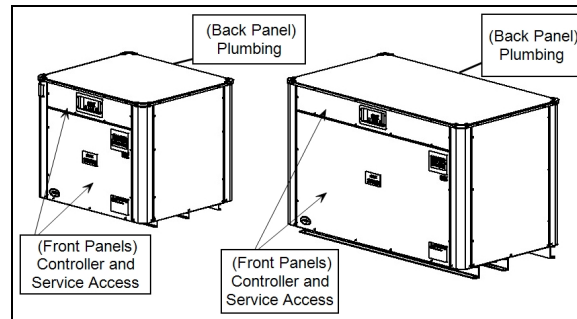

1.5.d Verifying Transformer Setting

Transformer voltage must be confirmed and set correctly depending on the measured voltage found on the site. Incorrect settings may cause heat pump damage. The following procedure will allow the installer to set the heat pumps transformer for the appropriate site voltage.

WARNING

Failure to heed the following may result in injury or death.

- The information contained in this section is intended for use by qualified technicians, familiar with electrical service-industry safety standards and methods.
1. Turn heat pump on by adjusting the thermostat to call for heating or cooling. If more than one heat pump is on site, turn them all on. Allow time for all heat pump compressors to activate.
 2. Measure the running site voltage.
 3. Confirm transformer tap is set for the measured site voltage. If more than one voltage tap is shown, select the voltage nearest to the running site voltage.

Example of heat pump transformer (Varies between models)

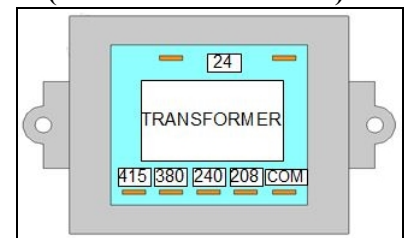

PLEASE NOTE -

- If more than one voltage is shown on the equipment's data plate, the factory default setting is usually the higher voltage on the transformer.
- As an example, a "208/230" voltage will be set to "240" from the factory.

1.5.e Three-Phase Adjustment

WARNING

Failure to heed the following may result in injury or death.

- The information contained in this section is intended for use by qualified technicians, familiar with electrical service-industry safety standards and methods.

If a three-phase unit fails to operate at start up, the orientation of the line voltage "field" wiring may need to be adjusted.

- Three-phase models are equipped with a Three-Phase Monitor or the ICM Digital Three-Phase Monitor.
- Units equipped with the ICM Digital Three-Phase Monitor will display a "Back Phase Rev" fault code on the phase monitor display.
- There is no display on the standard three-phase monitor.
- The phase monitor is located inside the electrical panel.

1. Deactivate power to the unit. **Confirm that power is off to all three legs using an electrical test meter set for the correct voltage.**

2. Switch position of the incoming power wires at each leg as follows, re-connect power, and attempt to restart the unit. If the unit fails to start, disconnect power. Verify off and proceed to next leg.

- Switch incoming power wires at L1 and L2 on the line side to the contactor.
- Switch incoming power wires at L1 and L3 on the line side to the contactor.
- Switch incoming power wires at L2 and L3 on the line side to the contactor.

3. When heat pump starts, disconnect power and verify off. Then confirm all line voltage connections are securely tightened. Reconnect power.

- If heat pump does not start, contact AquaCal® for further assistance. See "Contacting AquaCal AutoPilot, Inc." on page 1.

**Standard
Three-Phase
Monitor**



**ICM Digital
Three-Phase
Monitor**

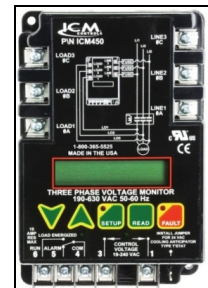

1.5.f Schematics

Schematics are located on the inside of the equipment access panel.

Some schematics have been included in the appendix.

PLEASE NOTE:

- Specifications are subject to change without notice.
- Schematics are available by calling AquaCal® Customer Support. See "Contacting AquaCal AutoPilot, Inc." on page 1.
 - Please have the complete model and serial number available.
 - See "Identifying Model Specifications" on page 42.

Schematic Document Numbers Chart		
Phase	Equipment Model Numbers	Schematic #
Single	WS03, WS05	LTM0738
Three	WS03, WS05	LTM0739
Three	WS10	LTM0196
Single	SP05	LTM0738
Three	SP05	LTM0739

1.5.g Connecting an External Controller

To support a direct connection to an external controller, AquaCal® heat pumps are equipped with optional terminal blocks. These terminals are on the microprocessor located on the low-voltage side of the electrical enclosure.



Failure to heed the following may result in injury or death.

- This section is only for qualified installers who are familiar with swimming pool and spa safety standards.
- The installer must be familiar with service industry techniques.
- Deactivate power while routing wiring to control board.



Failure to heed the following may result in damage to equipment.

- The wire size connecting the controller must be 16-gauge, 2-conductor or larger, low-voltage wire.
- Use direct connection (**dry contact**) provided on the microprocessor for external controllers.

Please confirm the type of external controller to be installed and follow the appropriate instructions.

- A **two-wire** controller (**with an internal thermostat**). *The user can set and adjust the temperature at the controller's screen.*
- A **three-wire** controller (**with an "OFF" position**). *The user adjusts the temperature at the heat pump. The user can select pool or spa mode or turn off the heat pump using the controller.*
- A **three-wire** controller (**without an "OFF" position**). *The user adjusts the temperature at the heat pump. The user can select pool or spa mode, but must turn off the heat pump at the heat pump display panel.*

Dry Contact Connection Points to the Microprocessor

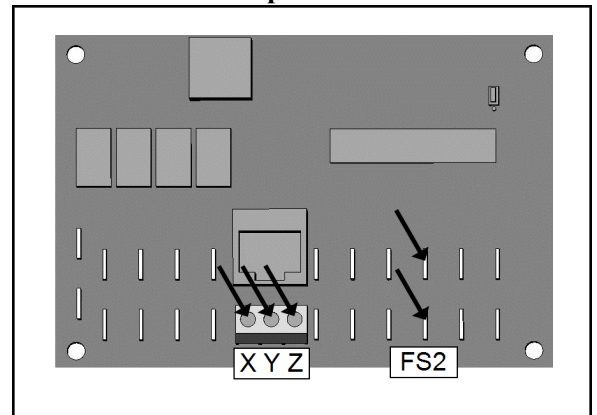

Two-wire controller (with internal thermostat):

1. Deactivate power to heat pump.
2. Remove heat pump electrical access panel.
3. Route the control wiring to the low voltage side of the electrical enclosure. Follow all National Electric Codes (NEC) unless State or Local guidelines supersede.
4. Connect the controller wires to the microprocessor as follows:
 - Connect one wire to "Y".
 - Connect other wire to "Z".
 - The polarity of the wire is not important.
5. Reattach heat pump access panel.
6. Apply power to heat pump.
7. Program heat pump for a two-wire controller. See "Using JAO interface" on page 25.

Three-wire controller (with "OFF" position):

1. Deactivate power to heat pump.
2. Remove heat pump electrical access panel.
3. Route the control wiring to the low voltage side of the electrical enclosure. Follow all National Electric Codes (NEC) unless State or Local guidelines supersede.
4. Connect the controller wires to the microprocessor as follows:
 - Connect "Low" or "Pool" wire to "X".
 - Connect "High" or "Spa" wire to "Z".
 - Connect "Common" wire to "Y".
5. Reattach heat pump access panel.
6. Apply power to heat pump.
7. Program heat pump for a three-wire controller. See "Using JAO interface" on page 25.

Three-wire controller (without an "OFF" position):

1. Deactivate power to heat pump.
2. Remove heat pump electrical access panel.
3. Route the control wiring to the low voltage side of the electrical enclosure. Follow all National Electric Codes (NEC) unless State or Local guidelines supersede.
4. Connect the controller wires to the microprocessor as follows:
 - Connect "Common" wire to one terminal of "FS2".
 - Connect "Spa" to other terminal of "FS2".
 - The third wire is not used.
5. Reattach heat pump access panel.
6. Apply power to heat pump.
7. Program heat pump for an external controller. See "Using FS2 interface" on page 25.

1.5.h Programming for an External Controller

Configure heat pump for external control.

Using JAO interface

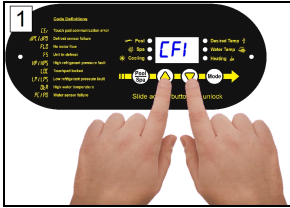

Press "Up" and "Down" buttons simultaneously until **CFI** appears.



Press "Pool / Spa" button until **LOC** is displayed.

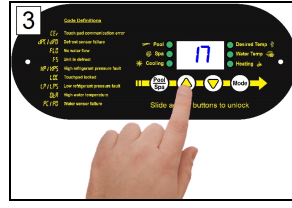

Press "Up" or "Down" to passcode. Default is "17".



Press "Pool / Spa" button once.



Press the "Pool / Spa" button until **JAO** is displayed.

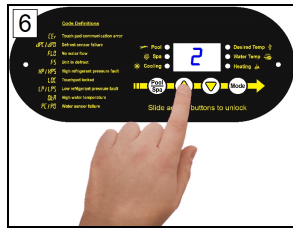

Press "Up" or "Down" button.

- "0" - none
- "2" - two-wire
- "3" - three-wire

Using F52 interface

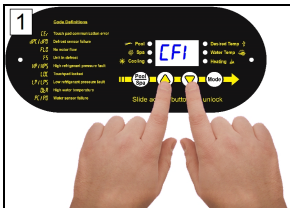

Press "Up" and "Down" buttons simultaneously until **CFI** appears.



Press "Pool / Spa" button until **LOC** is displayed.

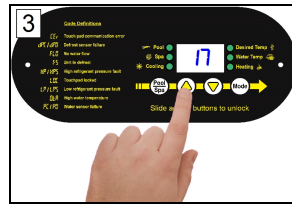

Press "Up" or "Down" to passcode. Default is "17".



Press "Pool / Spa" button once.

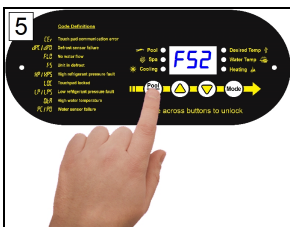

Press the "Pool / Spa" button until **F52** is displayed.

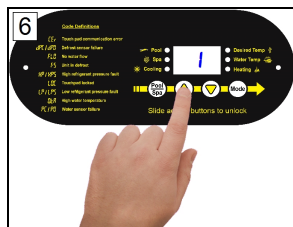

Press "Up" or "Down" button.

- "0" - none
- "1" - External

1.6 Service Level Programming

NOTICE

Failure to heed the following may result in damage to equipment.

- Service Level Programming must only be attempted by authorized personnel.
- Unauthorized adjustments in the Service Menu (beyond the **LDC** menu) may void the heat pump's warranty.
- Resetting the microprocessor to access a locked keypad will reset all settings to factory default including any installer-entered configuration. Re-programming all custom site condition settings will be required when using this reset. See "Reset to Factory Defaults Settings" on page 28.
- For further assistance, please see "*Contacting AquaCal AutoPilot, Inc.*" on page 1.

PLEASE NOTE -

Before changing multiple program options, it is recommended that the user lock option be disabled. See "User Lock Option (Disable)" on page 36.

The lockout option can be re-enabled after all changes are completed.

1.6.a Service Level Factory Defaults

Certain programming options have been preset at the factory. These options can be overwritten for certain site-specific conditions.

Table 3 - Default Program Parameters Chart

Code	Description	Default Value	Range
CFD	Call-Flex Options	0	Set to off at the factory.
dbP	Pool Dead-Band Differential	1°	Set at factory. Do not adjust.
dbS	Spa Dead-Band Differential	1°	Set at factory. Do not adjust.
dEL	Compressor Time Delay	1 (4 minutes)	Set to on (at 4 minutes) at the factory. Do not adjust.
dSC	Defrost Sensor	Factory Calibrated	Set at factory. Do not adjust.
dFd	Defrost Delay	Factory Calibrated	Set at factory. Do not adjust.

Code	Description	Default Value	Range
F52	Flow Switch / Automatic Thermostat Switching Option	0	0 = "No Switch" 1 = "Enable Switch"
JAO	External Controller	0	0 = "No Controller" 2 = "Two Wire Controller" 3 = "Three Wire Controller"
L0C	Service Level Entry Point	50	00 - 99
t5C	Water Sensor	Factory Calibrated	Set at factory. Do not adjust.

1.6.b Enter Service Level Programming



Press "Up" and "Down" buttons simultaneously until **CF 1** appears.



Press "Pool / Spa" button until **L0C** is displayed.

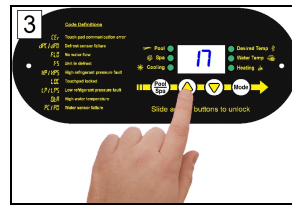

Press "Up" or "Down" to passcode. Default is "17".



Press "Pool / Spa" button once.

Programming for a Relay Switch

Configure heat pump for a relay or flow switch. This can provide automatic pool/ spa thermostat switching.

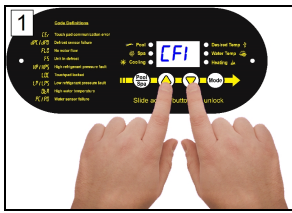

Press "Up" and "Down" buttons simultaneously until **CF 1** appears.

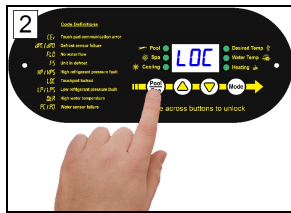

Press "Pool / Spa" button until **LOC** is displayed.

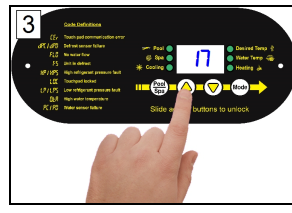

Press "Up" or "Down" to passcode. Default is "17".

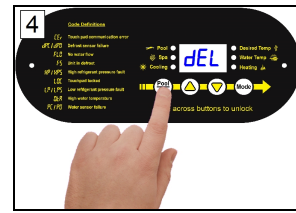

Press "Pool / Spa" button once.



Press the "Pool / Spa" button until **F52** is displayed.

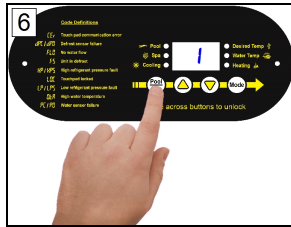

Press the "Up" or "Down"
 • "0" - not active
 • "1" - enable

Once the **F52** feature has been activated the "POOL / SPA" button will no longer function. The relay or flow switch is used to change between the pool and spa temperature settings.

Reset to Factory Defaults Settings

NOTICE

Failure to heed the following may result in damage to equipment.

- Using this option will reset ALL settings to their factory defaults including external controller settings and sensor calibrations. **DO NOT** perform this operation if unsure of site specific settings or how to reset them on the heat pump.
- If a qualified technician is unavailable, please see *"Contacting AquaCal AutoPilot, Inc." on page 1.*

1. Simultaneously Press "Pool / Spa" button and "Up" button until the display shows **888**.
2. Release buttons. Reset is complete.



1.7 Cleaning Equipment After Installation

Installer - If you need to clean equipment after installation, please use the following guidelines.

WARNING

Failure to heed the following may result in injury or death.

- Possible electric shock hazard - Deactivate power to all electrical devices on the pad when washing heat pump. Do not restore electrical power until equipment is completely dry.

NOTICE

Failure to heed the following may result in damage to equipment.

- Do not use a pressure cleaner to wash heat pump. Damage to heat pump components may result. If using a hose-end spray nozzle adjust spray pattern to low strength only.
- Do not spray water directly into the interior of the heat pump; damage to components may result.
- Do not use chemicals on the display panel.

Cleaning

1. Wash outside cabinet using a low-pressure water hose.
2. While the heat pump is still wet, use an approved cleaning agent to clean the exterior of the heat pump. **Do not use chemicals on the display panel.**
3. Use a detergent-dampened cloth to wipe the heat pump's exterior cabinet.
4. Flush all exterior with fresh water using a low-pressure water hose.
5. Dry the exterior cabinet using a soft cloth.

APPROVED CLEANING AGENTS*
Fantastic [®]
Formula 409 [®]
Cascade [®]
All Power Plain Detergent (3% Solution)

Table 4 - Cleaning Agents

Polishing

1. Polish the heat pump's cabinet panels using an approved polishing agent and following the manufacturer's instructions. Do not use chemicals on the display panel.
2. Rinse the heat pump panels with fresh water, wipe, and buff panels using a dry soft cloth.
3. Allow heat pump interior and surrounding equipment to "air-dry" for several hours prior to restoring electrical power.

APPROVED POLISHING AGENTS*
Simoniz [®] Wax
Glo-Coat [®]
Armor All [®] Protectant

Table 5 - Polishing Agents

- The trademarks used in approved cleaning and polishing agents are property of their owners and are not related to AquaCal®.

2 - Operation

2.1 Energizing Heat Pump

Activate power at external fuse box or the breaker box.

- The heat pump performs a lamp test.
- The display reads **BBB**.
- The heat pump then displays as normal. See "Display" on page 31.

2.2 Wake Up Heat Pump

The heat pump's control panel has a sleep mode. This is used to prevent rain that hits the display from making unwanted setting changes.

To wake up the control panel, tap a button on the display until it illuminates. Then slowly slide a finger across the buttons.

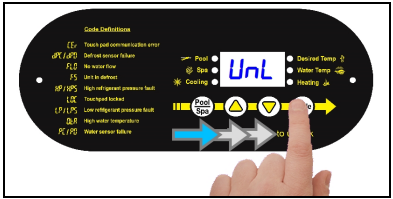

- The code **UnL** will briefly appear. Then either **FLD** or the water temperature will display.

2.3 Display Panel

The following information outlines the operation for a standard installation.

- Control Buttons will operate differently for custom installations; such as a heat pump connected to an external controller. See "Operating Heat Pump (With an External Controller)" on page 37.

Display Panel

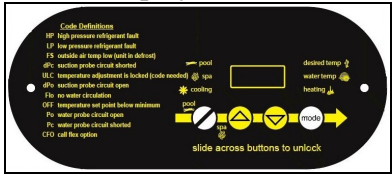

2.3.a Buttons

Buttons	Description
Display Lock	Sliding your finger across the buttons from left to right will temporarily disable the display lock.
Pool / Spa	Select either the pool or the spa thermostat.
Up Arrow	Used to increase temperature set point and navigate through menu options.
Down Arrow	Used to decrease temperature set point and navigate through menu options.
Mode	Select heat pump's operating mode.

2.3.b Display

Display	Description
75	The heat pump is on and displaying the current water temperature. In this example 75° F is displayed.
FLO	No water flow is detected. The filter pump is off or heat pump is not receiving correct water flow.
OFF	The heat pump has been turned off via the mode selector button or the temperature set point has been lowered below 45° F.
BBB	The control program is initializing. This displays only as power is applied to the heat pump.
CF I	Select water temperature format (in either Celsius or Fahrenheit).
ULC	Enable heat pump lockout feature.
ELC	Select pass code to lock the keyboard.
LDC	This is a Service Entry Point (not intended for use by the owner). The LDC code permits service personnel to enter a factory pass code to access adjustable calibration and site dependent setup parameters. Service adjustments are available to authorized installation and service personnel, only.

2.3.c Indicator Lights

Indicators	Description
Pool	The Heat Pump is referencing the pool thermostat.
Spa	The Heat Pump is referencing the spa thermostat.
Heating	Indicates the unit is heating the water. Please note - the compressor must be operating before this light will illuminate.
Cooling	Indicates the unit is cooling the water. Please note - the compressor must be operating before this light will illuminate.
Water Temp	Indicates current water temperature.
Desired Temp	Indicates temperature set point is displayed. This is displayed when "UP" or "DOWN" is selected.

2.4 User Level Programming

2.4.a User Level Factory Defaults

Certain programming options have been preset at the factory. These options can be overwritten for site-specific conditions.

NOTICE

Failure to heed the following may result in damage to equipment.

- Unauthorized adjustments in the Installer Menu (beyond the LDC menu) may void the heat pump's warranty.

- For further assistance, please see "Contacting AquaCal AutoPilot, Inc." on page 1.

Table 6 - Factory Defaults

Code	Description	Default Value	Range
<i>OFF</i>	Heat Pump is deactivated.	<i>OFF</i>	
<i>HEA</i>	Heat water to point set on thermostat.		
<i>COO</i>	Cool water to point set on thermostat.		
<i>RCH</i>	Set to maintain a water temperature set on the thermostat.		
<i>CF 1</i>	Celsius / Fahrenheit Selection	1	0 = Celsius 1 = Fahrenheit
<i>ELC</i>	Enter Lock Code	0	0 - 99
<i>ULC</i>	User Lock Code	0	0 = "User Lock Disabled" 1 = "User Lock Enabled"

2.4.b Selecting Celsius or Fahrenheit

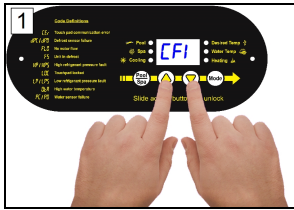

Press and Hold
"UP" and "DOWN"
until **CF 1** displays.

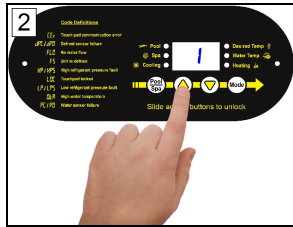

Press "UP" or
"DOWN" button to
select.

"0" - Celsius
"1" - Fahrenheit

2.4.c Setting Operating Mode

1. Press "Mode / Enter" button until desired mode is displayed.
2. After a certain amount of time, the display will show the selected mode and current water temperature.
 - Heating Mode - After fan and compressor starts, the red "Heating" light will activate.
 - Cooling Mode - After fan and compressor starts, the blue "Cooling" light will activate.
 - Holding Mode - After fan and compressor starts, the heat pump will attempt to maintain the set temperature within 3°. The red "Heating" or blue "Cooling" light will activate.
 - Off - The heat pump will indicate it is deactivated. The current water temperature will be displayed.



Heating Mode



Cooling Mode

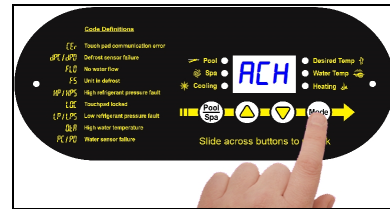

Holding Mode



Deactivate Heat Pump

Heating / Cooling modes only available on select equipment. Confirm heat pump features before setting a mode.

2.4.d Setting Thermostats

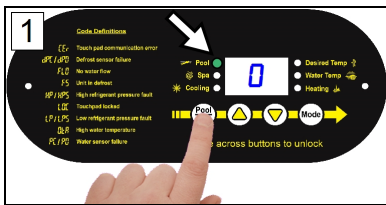

Select "POOL" or "SPA"



Press "UP" or "DOWN" to the desired temperature.

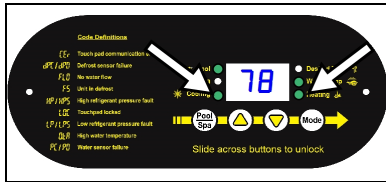

- The heating indicator will illuminate when heating the water.
- The cooling indicator will illuminate when cooling the water.

2.4.e User Lock Option (Enable)

The user-lock feature allows the heat pump display panel to be "locked". This can prevent unauthorized temperature adjustments in commercial applications.

- Do not confuse a user-lock with the display lock. See "Wake Up Heat Pump" on page 31.
- If **LDC** is briefly displayed, followed by a "0", the heat pump is already locked.
- If the user-lock code has been misplaced, please contact AquaCal® for further assistance.



Hold "UP" and "DOWN" until **CF** displays.



Press "POOL / SPA" button until **ELC** is displayed.



Press "UP or "DOWN" button to change or add a numerical password



Press "POOL / SPA" button to save the password.

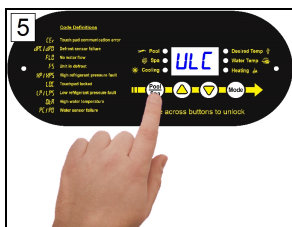

Press "POOL / SPA" button until **ULC** is displayed.



Press "Up" button till "1" is displayed to enable.

2.4.f User Lock Option (Disable)

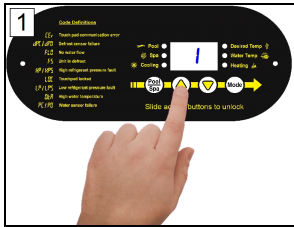

Use "UP" button to enter existing password.

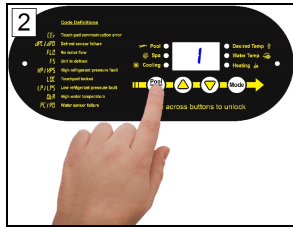

Press "Pool / Spa" button to unlock.



Hold "UP" and "DOWN" buttons until **CF 1** is displayed.

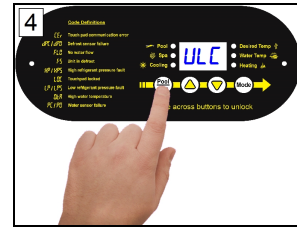

Press "POOL / SPA" button until **ULC** is displayed

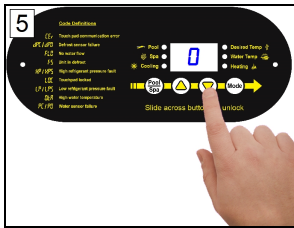

Press "DOWN" button until "0" is displayed.

2.4.g Using Pass Code to Access Heat Pump

If **LOC** is briefly displayed when attempting to change a heat pump's settings followed by a "0", the heat pump is in a user-lock mode. A numerical pass code is required to proceed.



Press "UP" or "DOWN" arrow to enter pass code.

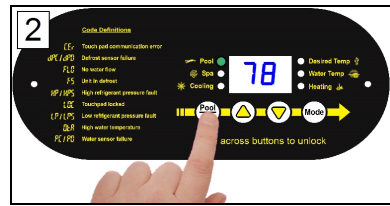

Press "POOL / SPA" button to unlock.

NOTE -

- After ten seconds of inactivity, the heat pump's display lock will activate. See "Wake Up Heat Pump" on page 31.
- If the user-lock code has been misplaced, please contact AquaCal® for further assistance.

2.4.h Operating Heat Pump (With an External Controller)

Controller with an internal thermostat control

Activating Heat Pump

1. Set the desired temperature at the external controller.
2. Use the external controller to select either the "Pool" or "Spa" to heat.

Deactivating Heat Pump

- Set the external controller to "OFF".

Please note - If equipped, the heat pump's cooling function **will be disabled** when using this type of controller.

If the cooling function is needed, the heat pump must be temporarily reprogrammed for local control.

- Set the heat pump to operate with external control temporarily set to "none".
- See "Programming for an External Controller" on page 24.
- It is OK to leave external controller wires in place while the heat pump is set for local control.

Controller with 2 positions - ("Pool" and "Spa" - no internal thermostat control)

Activating Heat Pump

1. Set the desired temperatures on the heat pump thermostats. See "Setting Thermostats" on page 35.
2. Use the external controller to select either the "Pool" or the "Spa" thermostat.
 - *Rapid movement between thermostats without a "rest" between each change can cause a missed signal by the heat pump.*

Deactivating Heat Pump

- Go to the heat pump and set the mode to "OFF". See "Setting Operating Mode" on page 34.

Please note - If equipped, the heat pump's cooling function **will be disabled** when using this type of controller.

If the cooling function is needed, the heat pump must be temporarily reprogrammed for local control.

- Set the heat pump to operate with external control temporarily set to "none".
- See "Programming for an External Controller" on page 24.
- It is OK to leave external controller wires in place while the heat pump is set for local control.

Controller with 3 positions - ("High", "Low", and "Off" - no internal thermostat control):

Activating Heat Pump

1. Set the desired temperatures on the heat pump thermostats. See "Setting Thermostats" on page 35.
2. Use the external controller and select the "High" or "Low" thermostat.
 - *When changing between thermostats, select "Off" first. Then select desired thermostat.*
 - *Rapid movement between thermostats without a "rest" between each change can cause a missed signal by the heat pump.*

Deactivating Heat Pump

- Set the external controller to "OFF".

3 - Maintenance

3.1 Water Chemistry

Check water chemistry regularly and maintain within recommended levels. Standards vary in different residential and commercial applications. Follow all local applicable codes.

NOTICE

Failure to heed the following may result in damage to equipment.

- Do not allow water to flow through heat pump when refinishing or acid washing a pool. Either use an installed bypass to route water away from heat pump or deactivate filter pump.
- To avoid damage to equipment, monitor and maintain chemistry within recommended levels.

CHEMISTRY LEVEL CHART (RESIDENTIAL)		
CHEMICAL	POOLS	SPAS
Chlorine	1.0 – 3.0 ppm	3.0 – 5.0 ppm
Bromine	2.0 – 6.0 ppm	2.0 – 6.0 ppm
Cyanuric Acid	30 – 50 ppm	30 – 50 ppm
pH	7.4 – 7.6 ppm	7.4 – 7.6 ppm
Total Alkalinity	80 – 120 ppm	80 – 120 ppm
Calcium Hardness	200 – 400 ppm	150 – 250 ppm
Total Dissolved Solids*	0 – 1,500 ppm	1,500 ppm above start-up of total dissolved solids in spas

* Salt from a chlorine generator is not included in Total Dissolved Solids.

3.2 Planned Maintenance

An annual inspection and maintenance program is strongly recommended starting no later than one year after installation of the heat pump. In harsh environments or coastal areas a bi-annual inspection is recommended. See recommended inspection checklist.

AquaCal® can perform this service in limited areas. Contact Customer Support for more information.

⚠ WARNING

Failure to heed the following may result in injury or death.

- Annual inspection and service must be performed by a qualified heat pump specialist in order to prevent physical injury or damage to equipment. For tasks requiring handling refrigerant, an HVAC license is required.

Recommended Inspection Checklist:
1. Clean Water Source - Source Coil (As Applicable)
2. Check Contactor Points
3. Clean Heat Pump Cabinet
4. Check Flow / Pressure Switch
5. Apply Rust Inhibitors (As applicable)
6. Verify / Check Water Flow Delta
7. Check Compressor Capacitor Values
8. Check Compressor Amperage Draw
9. Check Internal Electrical Connections
10. Check Operating Refrigerant Pressures (As Applicable)
11. Check Ambient and Water Temperature Sensors
12. Check Proper Line and Control Voltage to Unit
13. Identify Insect and Rodent Issues with Unit
14. Identify Environmental Conditions of Concern (Run-Off, Sprinklers, etc.)
15. Perform Operating Orientation (As Applicable)

3.3 Winterizing

Failure to properly winterize the heat pump as needed may result in serious equipment damage.

WARNING

Failure to heed the following may result in injury or death.

- Deactivate all electrical power to heat pump before performing hard freeze procedures.

NOTICE

Failure to heed the following may result in damage to equipment.

- Failure to winterize heat pump may result in serious equipment damage. Freeze damage is not covered under the heat pump warranty.
- While the plumbing connections are in the winterized condition (not fully tightened), it is imperative that water not run through the heat pump. Loss of water through loose plumbing connections may result in damage to circulation pump, pool and spa structures, and other equipment.

Light Freeze Conditions

A light freeze is when the ambient air temperature falls below 32 degrees Fahrenheit for less than 8 hours. Typically during light freeze conditions circulating (or moving) water will not freeze. Temporarily activate the filter pump for continuous operation during light freeze conditions.

Hard Freeze Conditions

A hard freeze is when the ambient air temperature falls below 32 degrees Fahrenheit for more than 8 hours. In areas where this condition is prevalent and sustained, the heat pump **MUST** be winterized for hard freeze conditions. Follow the correct procedure depending on the type of heat exchanger found in the heat pump.

PLEASE NOTE - WHEN WINTERIZING WATER SOURCE UNITS

For Water Source units both the pool and the source sides must be winterized. Your Water Source unit may have two different heat exchanger types on pool and source sides. Be sure to properly identify and follow the correct procedure for both heat exchanger types in your unit.

Identify Exchanger:

1. Deactivate all electrical power to heat pump.
2. Deactivate filter pump.
3. Remove front access panel. See "Access Panels" on page 21.
4. Identify heat exchanger from illustrations in this section. Then follow procedure for the appropriate heat exchanger.

Titanium ThermoLink® Exchanger (with no Drain)

5. Reinstall front access panel.
6. Disconnect the plumbing to the heat pump at connection unions (removal is counter-clockwise).
7. Allow water to drain completely from the heat pump. Expect to see a lot of water drain out at first, and then a small amount to continue to drain out over a long period.
8. After heat pump has fully drained, partially reconnect plumbing connection unions.
9. Winterizing is complete.
10. When ready to use heat pump again, hand-tighten connection unions. Reconnect electrical power, and set the operating mode on the heat pump. Activate filter pump.

No Drain



Cupronickel Tube in Tube Exchanger

5. Reinstall front access panel.
6. Disconnect the plumbing to the heat pump at connection unions (removal is counter-clockwise).
7. Place a garden hose into the inlet side of the heat pump; wrap a clean rag around the hose to form a temporary seal.
8. Turn on the garden hose water supply.
9. Allow water to run through the heat exchanger for 2-3 minutes; fresh water should be seen exiting the pool's out-port.
10. Place a garden hose into the outlet side inlet of the heat pump; wrap a clean rag around the hose to form a temporary seal.
11. Turn on the garden hose water supply.
12. Allow water to run through the heat exchanger for 2-3 minutes; fresh water should be seen exiting the pool's in-port.
13. Place an air hose into the pool inlet of the heat pump; wrap a clean rag around the hose to form a temporary seal.
14. Push all water from the water circuit using compressed air at approximately 50 psig. The residual water should be forced out of the heat pump's water outlet.
15. Allow compressed air to blow into the heat pump inlet for at least 15-20 seconds after the water stops coming out.
16. Repeat process on the outlet side.
17. Partially reconnect plumbing connection unions.
18. Winterizing is complete.
19. When ready to use heat pump again, hand-tighten connection unions. Reconnect electrical power, and set the operating mode on the heat pump. Activate filter pump.

**Cupronickel
(Orientation
depends
on model)**

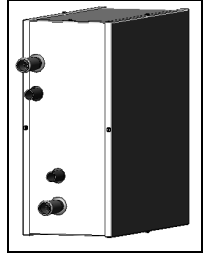

4 - Appendix

4.1 Identifying Model Specifications

1. Find Data Plate - The data plate is usually posted on the side of the equipment or the inside of the heat pump's access plate.
2. Find the model number on the data plate. The first letters and numbers indicate the model type.
3. The complete model number identifies the equipment's specifications.

Data Plate Example

MINIMUM CIRCUIT AMPACITY <input type="text"/>	MADE IN THE USA
ELEC. SERVICE: VOLTS <input type="text"/> PH <input type="text"/> HZ <input type="text"/>	
MAXIMUM TIME DELAY FUSE OR HACR BREAKER <input type="text"/> 5	
COMPRESSOR VOLTS <input type="text"/> R.L.A. <input type="text"/> L.R.A. <input type="text"/>	
FAN MOTOR VOLTS <input type="text"/> H.P. <input type="text"/> F.L.A. <input type="text"/>	
REFRIGERANT: Circuit - Factory charged <input type="checkbox"/> Only oz/Kg <input type="text"/>	
Tested to <input type="checkbox"/> psig High side / <input type="checkbox"/> psig Low side	
OUTDOOR USE	
AQUA CAL, INC. A TEAM HORNER COMPANY 2737 24 TH STREET NORTH ST. PETERSBURG, FL 33713 FACTORY SERVICE 727-523-5642	MODEL NUMBER <input type="text"/> IIIBAR CODEIII SERIAL NUMBER <input type="text"/> IIIBAR CODEIII

Model Number Example

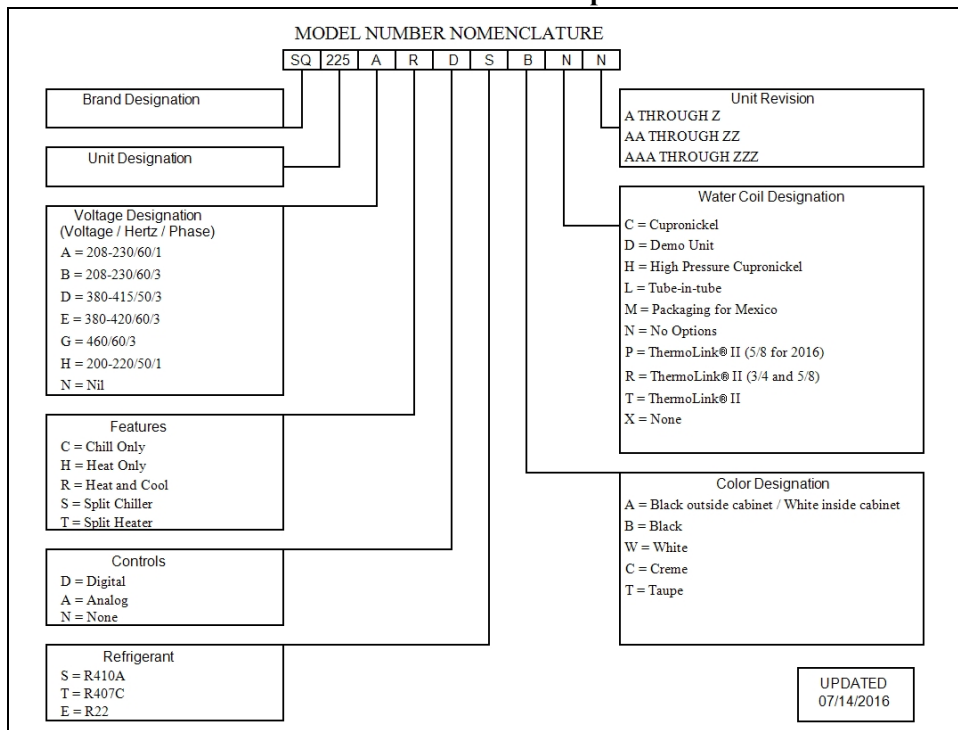

4.2 Weights

NOTE:

Specifications subject to change.

Model Type	Model Number	Install Weight
Water Source	WS03 (source side Titanium)	290 Pounds
Water Source	WS03 (source side Cupronickel)	300 Pounds
Water Source	WS05 (source side Titanium)	300 Pounds
Water Source	WS05 (source side Cupronickel)	320 Pounds
Water Source	WS10 (source side Titanium)	745 Pounds
Water Source	WS10 (source side Cupronickel)	840 Pounds
SunPower	SP05 (source side Titanium)	340 Pounds
SunPower	SP05 (source side Cupronickel)	350 Pounds

Table 7 - Equipment Weight

4.3 Heating Recommendations

The following recommendations will reduce the amount of time required to heat a pool. **If unsure of equipment heating capability, review equipment data plate.** See "Identifying Model Specifications" on page 42.

1. Confirm heat pump mode has been set to heating mode.
2. Set thermostat to desired water temperature.
3. Temporarily set the filter pump for continuous operation.
 - This will allow the Heat Pump the time required to heat the water at start-up.
 - After the water has reached the desired temperature, reset the filter pump to normal operating time-frames.
4. Use a pool cover or blanket to reduce heating time.

4.4 Cooling Recommendations

The following recommendations will reduce the amount of time required to cool a pool or cold plunge application. **If unsure of equipment cooling capability, review equipment data plate.** See "Identifying Model Specifications" on page 42.

1. Confirm heat pump mode has been set to cooling mode.
2. Set thermostat to desired water temperature.
3. Temporarily set the filter pump for continuous operation.
 - This will allow the Heat Pump the time required to cool the water at start-up.
 - After the water has reached the desired temperature, reset the filter pump to normal operating time-frames.

4.5 Available Accessories

Accessories may be purchased through an authorized dealer of AquaCal products.

For further assistance, please see "Contacting AquaCal AutoPilot, Inc." on page 1.

5 lb Bypass Valve Kit (# STK0135)

- When high flow rates are outside recommended specifications, please use this kit or an alternative bypass valve system.
- This kit can be used to control excessive water flow through the heat pump. It provides automatic flow adjustments for most applications.

Automatic Sequencing Controller

- An Automatic Sequencing Controller (ASC) provides easy control of all units from one lead unit and prevents the simultaneous start-up of multiple heat pumps.
- Site voltage drop is minimized and utilities are not subjected to large in-rush demands of electrical current.
- Part number is based on number of heat pumps to be controlled. Call AquaCal® for assistance with correct configuration. See "Contacting AquaCal AutoPilot, Inc." on page 1.

External Flow Relay (Grid Flow Switch) Kit (0040S)

- Used when the pool / spa elevation is higher than the heat pump.
- Also used for automatic pool / spa thermostat switching.

PLEASE NOTE -

The kit is not to be used on applications exceeding 50 PSI.

Liquid Blankets

- An invisible liquid heat barrier designed to retain heat and extend the swimming season.
- AquaCal® recommends [Lo-Chlor](#)® Aqua Blanket™.



Plumbing Unions:

SIZE	PART NUMBER
1 INCH	PLP0059
2 INCH	PLS2627

Remote Control Kit (STK0070)

- A remote (wired) control kit allows for full control of the heat pump from up to 100 feet from the equipment.

Temperature Port Kit

- This kit is used to install a temperature port.
- This port can be used to adjust water flow using Delta-T. The kit comes with port, installation components, and a temperature probe.

PART NUMBER

Kit # (STK0096)

4.6 Schematics

Schematics are located on the inside of the equipment access panel.

Some schematics have been included in the appendix.

PLEASE NOTE:

- Specifications are subject to change without notice.
- Schematics are available by calling AquaCal® Customer Support. See "Contacting AquaCal AutoPilot, Inc." on page 1.
 - Please have the complete model and serial number available.
 - See "Identifying Model Specifications" on page 42.

Schematic Document Numbers Chart		
Phase	Equipment Model Numbers	Schematic #
Single	WS03, WS05	LTM0738
Three	WS03, WS05	LTM0739
Three	WS10	LTM0196
Single	SP05	LTM0738
Three	SP05	LTM0739

NOTES UNLESS OTHERWISE SPECIFIED
 1. USE COPPER CONDUCTORS ONLY.
 2. TO BE WIRED IN ACCORDANCE WITH NATIONAL ELECTRIC (NEC) & LOCAL CODES.
 3. EXTERNAL CONTROLLER HOOK UP:

- A. TWO-WIRE CONTROLLERS (JANDY RS 4,6,8, COMPOOL LX 3800)
 a. WIRES CONNECT TO Y & Z ON THE MICROPROCESSOR.
 b. WITH HEATER DISPLAYING WATER TEMPERATURE, PRESS THE UP & DOWN ARROW AT THE SAME TIME UNTIL CF1 APPEARS.
 c. PUSH THE POOL/SPA KEY UNTIL LOC APPEARS PUSH THE UP ARROW UNTIL 50 APPEARS.
 d. PUSH THE POOL SPA KEY UNTIL JAO DISPLAYS; PUSH THE UP ARROW UNTIL 2 DISPLAYS.
 e. WHEN THE WATER TEMPERATURE DISPLAYS, TURN BOTH THERMOSTATS TO THE OFF POSITION.
 B. THREE-WIRE CONTROLLERS (JANDY AQUASWITCH, COMPOOL) (USE ONLY COMMON AND THE SPA TERMINALS IN THE CONTROLLER)
 a. WIRES CONNECT TO FS2 ON THE MICROPROCESSOR.
 b. WHEN THE HEATER DISPLAYS WATER TEMPERATURE, HOLD THE UP AND DOWN ARROW AT THE SAME TIME UNTIL CF1 APPEARS.
 c. PUSH THE POOL/SPA KEY UNTIL LOC APPEARS; PUSH THE UP ARROW UNTIL 50 DISPLAYS.
 d. PUSH THE POOL/SPA KEY UNTIL FS2 DISPLAYS; PUSH THE UP ARROW UNTIL 1 APPEARS.
 e. WHEN THE WATER TEMPERATURE DISPLAYS, SET BOTH THE THERMOSTATS.

REVISIONS				
REV.	PCA# / DESCRIPTION	DATE	CHG	ENG
REL-A	INITIAL RELEASE	12/17/09	SCF	DKS
REL-B	REMOVED PHASE ROTATION CONTROLLER INSTRUCTIONS	8/1/14	TD	TD
REL-C	ADDED D-VOLTAGE NOTES	6/9/15	TD	TD

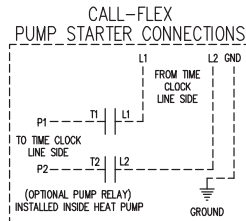
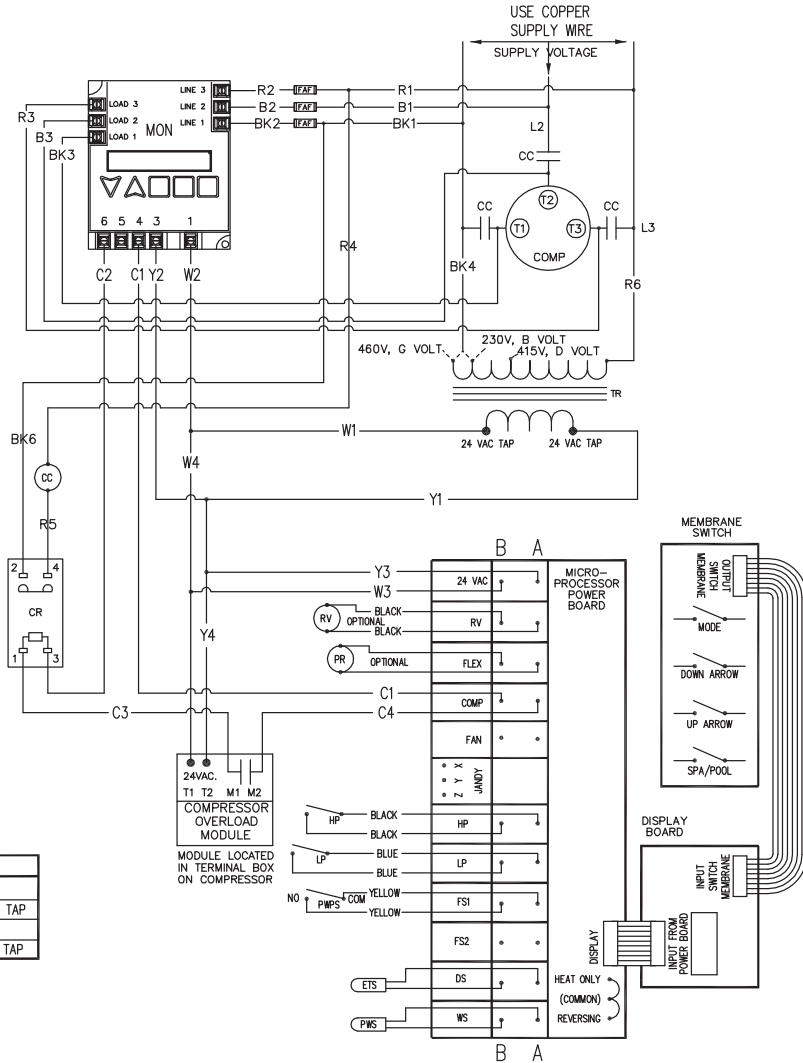

VOLTAGE CODES	
CODE	DESCRIPTION
B	200-230 VAC, 60 Hz, 3Ø-USE 240 VAC TRANSFORMER TAP
G	460 VAC, 60 Hz, 3Ø-USE 460 VAC TRANSFORMER TAP
D	380-415 VAC, 50 Hz, 3Ø-USE 415 VAC TRANSFORMER TAP

LEGEND	
————	FACTORY WIRING
-----	FIELD WIRING
CC	COMPRESSOR CONTACTOR
COMP	COMPRESSOR MOTOR
ETS	EVAPORATOR TEMPERATURE SENSOR
HP	HIGH PRESSURE SWITCH (REFRIGERANT)
LP	LOW PRESSURE SWITCH (REFRIGERANT)
MON	DIGITAL VOLTAGE MONITOR
PR	PUMP RELAY
PWPS	POOL WATER PRESSURE SWITCH
PWS	POOL WATER TEMPERATURE SENSOR
RV	REVERSING VALVE
TR	TRANSFORMER

WIRE COLORS	
B	BLUE
BK	BLACK
R	RED
W	WHITE
C	BLUE/WHITE TRACER

CAD GENERATED DRAWING; DO NOT MANUALLY CHANGE

APPROVALS	DATE
DRAWN BY: S. FREDETTE	12/17/09
CHECKED BY: D. SMITH	12/18/09
APPROVED BY: SEB	12/18/09

THE INFORMATION CONTAINED IN THIS DRAWING IS THE SOLE PROPERTY OF AQUACAL. ANY REPRODUCTION IN PART OR WHOLE WITHOUT WRITTEN PERMISSION OF AQUACAL IS PROHIBITED.

America's Leading Pool Heat Pump Manufacturer
 2737 24th St. No.
 St. Petersburg, FL 33713

SCHEM, W/S, DIGITAL MONITOR	
SIZE DWG. NO. A LTM0196	REV. A
DO NOT SCALE DRAWING	SCALE: N/A CAD FILE: LTM0196 SHEET 1 OF 1

NOTES UNLESS OTHERWISE SPECIFIED:
 1. USE COPPER CONDUCTORS ONLY.
 2. TO BE WIRED IN ACCORDANCE WITH NAT'L ELEC (NEC) & LOCAL CODES.
 3. CONNECT TRANSFORMER TO CORRECT VOLTAGE.
 4. CUT RED WIRE ON PHASE ROTATION MONITOR FOR D-VOLT LINE VOLTAGE CODES:
 B: 208-230VAC/60HZ/3Ø
 D: 380-415VAC/50HZ/3Ø
 G: 460VAC/60HZ/3Ø

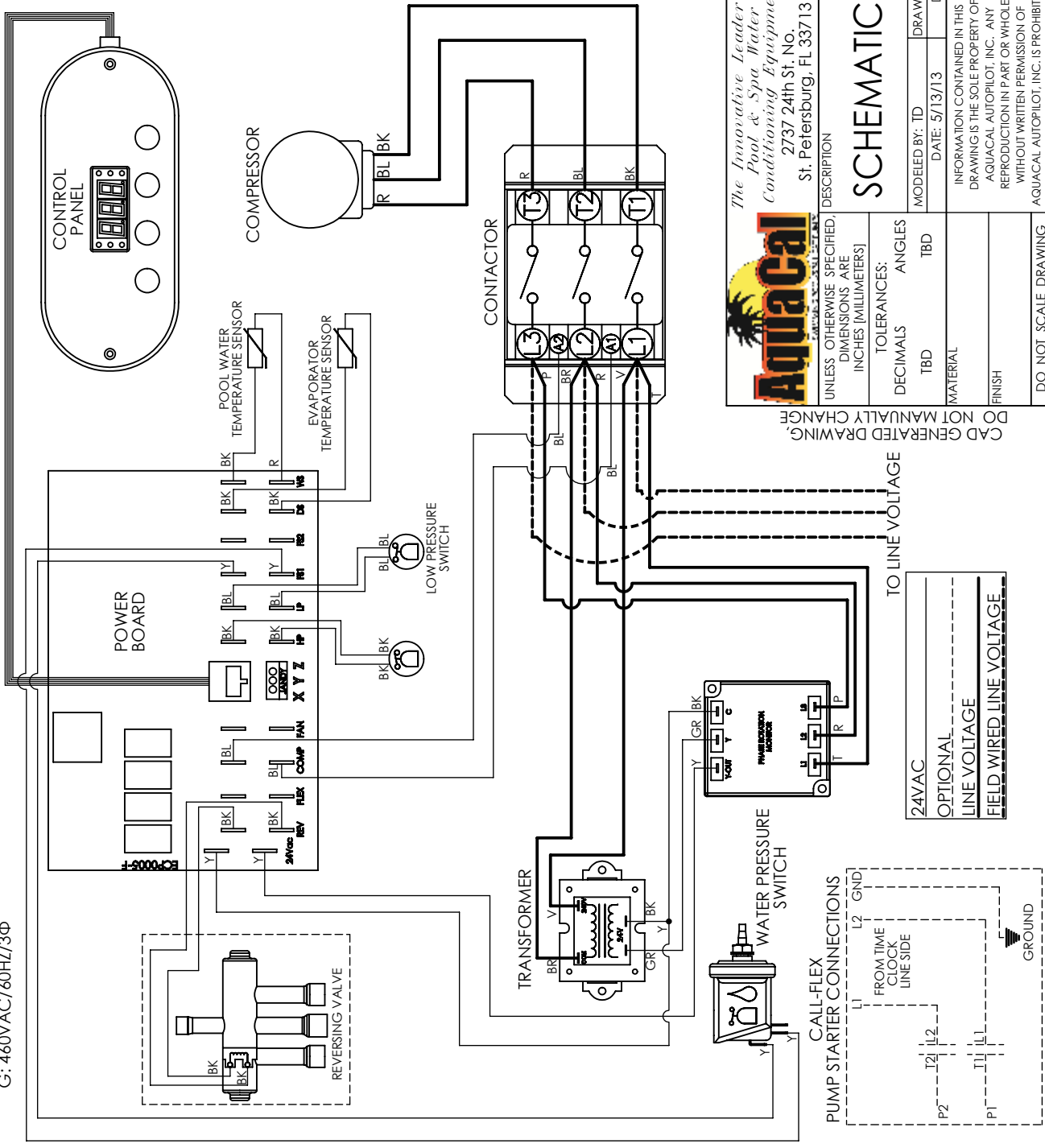

COLOR CODE

BL:	BLUE
BK:	BLACK
BR:	BROWN
BR/W:	BROWN AND WHITE
G:	GREEN
GR:	GRAY
P:	PINK
R:	RED
T:	TAN
V:	VIOLET
Y:	YELLOW
W:	WHITE



AUTOPILOT SYSTEMS, INC.
 SALT CHLORINE GENERATORS
 2737 24th St. No.
 St. Petersburg, FL 33713

SCHEMATIC, 3PH, WATERSOURCE

MODELED BY: TD	DRAWN BY: TD	PROJECT ENG: TD	CHKD BY: TD
DATE: 5/13/13	DATE: 8/5/13		
INFORMATION CONTAINED IN THIS DRAWING IS THE SOLE PROPERTY OF AQUACAL AUTOPILOT, INC. ANY REPRODUCTION IN PART OR WHOLE WITHOUT WRITTEN PERMISSION OF AQUACAL AUTOPILOT, INC., IS PROHIBITED.			
DWG. NO. LTM0739		SCALE: 1:4	REVISION: DEV-G
DWG. SIZE: A		SHEET 1 OF 1	
CAD FILE: LTM0333			

UNLESS OTHERWISE SPECIFIED, DIMENSIONS ARE INCHES (MILLIMETERS)
 TOLERANCES:
 DECIMALS: TBD
 ANGLES: TBD
 MATERIAL: TBD
 FINISH: DO NOT SCALE DRAWING

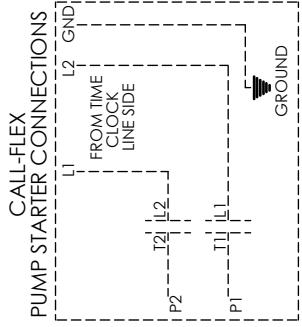

REVISION TABLE

REV.	PCA NUMBER/DESCRIPTION	CHANGED BY	DATE
DEV-D	ADDED COMPRESSOR CONTACTOR WIRES	TOMD	9/16/2014
DEV-E	ADDED REVERSING VALVE OPTION	TOMD	10/27/2014

- NOTES UNLESS OTHERWISE SPECIFIED:
 1. USE COPPER CONDUCTORS ONLY.
 2. TO BE WIRED IN ACCORDANCE WITH NAT'L ELEC (NEC) & LOCAL CODES.
 3. CONNECT TRANSFORMER TO CORRECT VOLTAGE.
 4. LINE VOLTAGE CODES:
 A: 208-230VAC/60HZ/1Φ
 H: 200-240VAC/50HZ/1Φ

REVISION TABLE

REV.	PCA NUMBER/DESCRIPTION	CHANGED BY	DATE
DEV-G	ADDED REVERSING VALVE OPTION	TOMD	10/27/2014

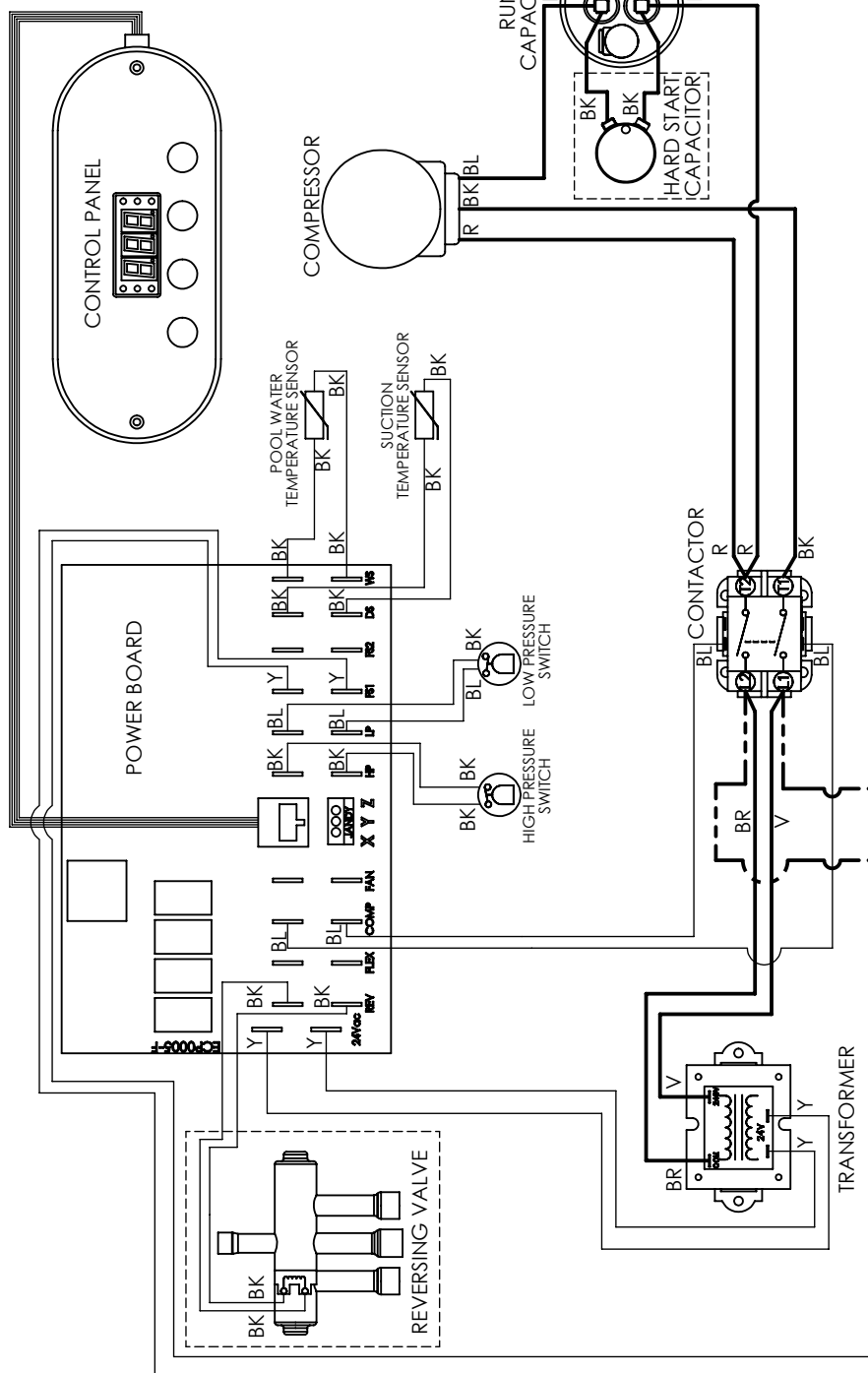

COLOR CODE
 BL: BLUE
 BK: BLACK
 BR: BROWN
 BR/W: BROWN AND WHITE
 G: GREEN
 R: RED
 V: VIOLET
 Y: YELLOW
 W: WHITE

AquaCal SALT CHLORINE GENERATORS
The Innovative Leader In Pool & Spa Water Conditioning Equipment
AUTOPILOT SYSTEMS INC.
 2737 24th St. No. St. Petersburg, FL 33713
 SALT CHLORINE GENERATORS

DESCRIPTION		PROJECT ENG: TD		CHKD BY: TD	
MODELED BY: TD	DRAWN BY: XXX	DATE: 5/13/13	DATE: 1/1/2011		
INFORMATION CONTAINED IN THIS DRAWING IS THE SOLE PROPERTY OF AQUACAL AUTOPILOT, INC. ANY REPRODUCTION IN PART OR WHOLE WITHOUT WRITTEN PERMISSION OF AQUACAL AUTOPILOT, INC., IS PROHIBITED.					
TOLERANCES: ANGLES		TBD		LIM0738	
DECIMALS	TBD	SCALE	DWG SIZE	REVISION	DEV-F
DO NOT SCALE DRAWING		1:4 A		SHEET 1 OF 1	
DO NOT MANUALLY CHANGE CAD GENERATED DRAWING.		CAD FILE: LTM0350		Last Revision: 03/15/13	

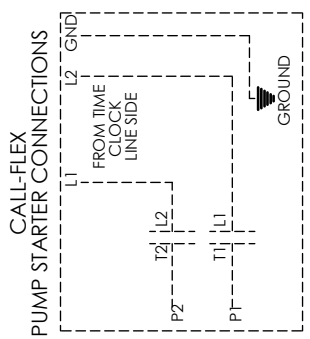

24VAC
 OPTIONAL LINE VOLTAGE
 FIELD WIRED LINE VOLTAGE

- NOTES UNLESS OTHERWISE SPECIFIED:
 1. USE COPPER CONDUCTORS ONLY.
 2. TO BE WIRED IN ACCORDANCE WITH NAT'L ELEC. (NEC) & LOCAL CODES.
 3. CONNECT TRANSFORMER TO CORRECT VOLTAGE.
 4. LINE VOLTAGE CODES:
 A: 208-230VAC/60HZ/1Φ
 H: 200-240VAC/50HZ/1Φ

REVISION TABLE

REV.	PCA NUMBER/DESCRIPTION	CHANGED BY	DATE
DEV-G	ADDED REVERSING VALVE OPTION	TOMD	10/27/2014

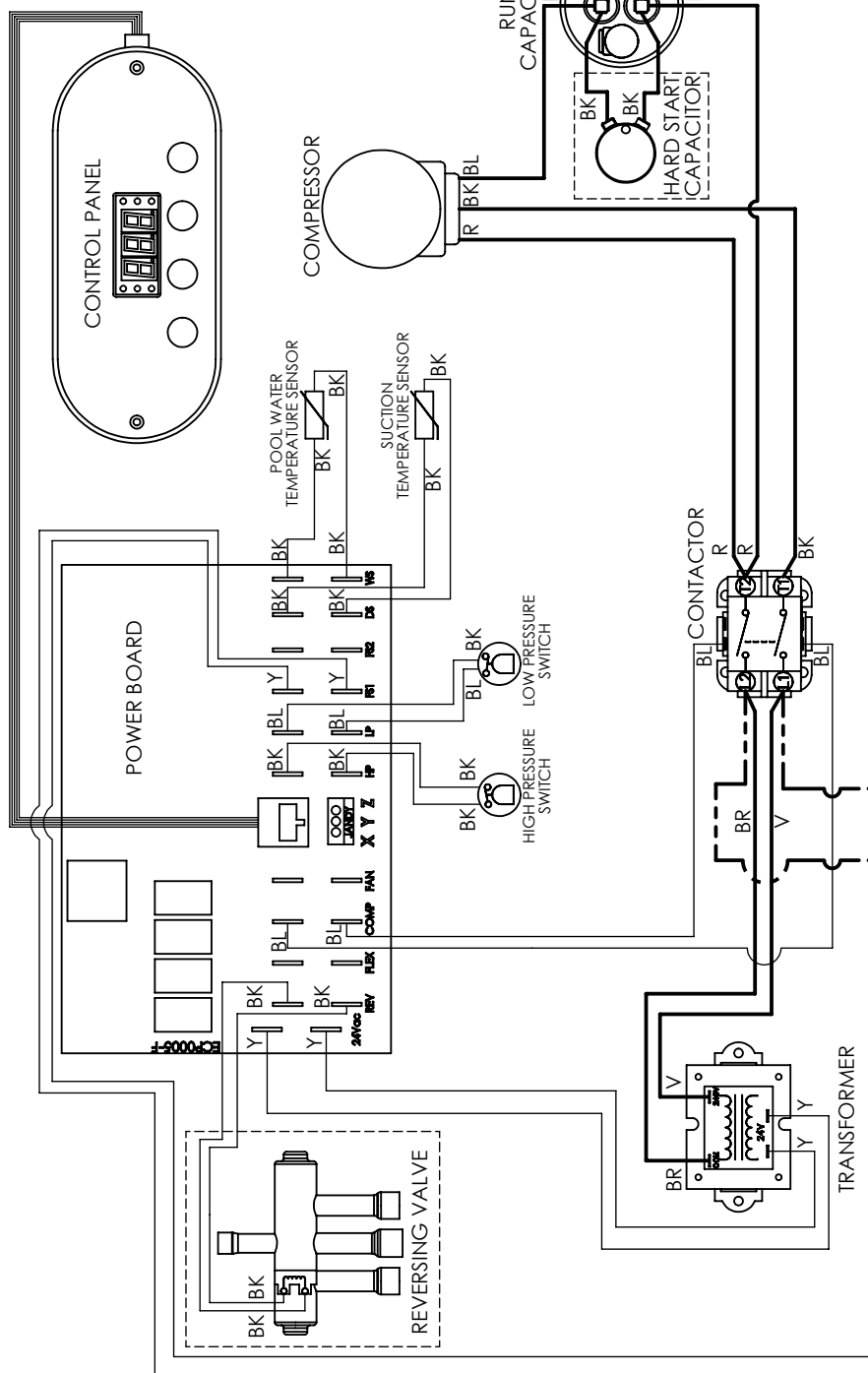

COLOR CODE
 BL: BLUE
 BK: BLACK
 BR: BROWN
 BR/W: BROWN
 AND WHITE
 G: GREEN
 R: RED
 V: VIOLET
 Y: YELLOW
 W: WHITE

AquaCal SALT CHLORINE GENERATORS
The Innovative Leader In Pool & Spa Water Conditioning Equipment
AUTOPILOT SYSTEMS INC.
 2737 24th St. No. St. Petersburg, FL 33713

DESCRIPTION		PROJECT ENG: TD		CHKD BY: TD	
MODELED BY: TD	DRAWN BY: XXX	DATE: 5/13/13	DATE: 1/1/2011		
UNLESS OTHERWISE SPECIFIED, DIMENSIONS ARE INCHES (MILLIMETERS)					
TOLERANCES: ANGLES					
TBD	TBD				
MATERIAL					
FINISH					
DO NOT SCALE DRAWING					
INFORMATION CONTAINED IN THIS DRAWING IS THE SOLE PROPERTY OF AQUACAL AUTOPILOT, INC. ANY REPRODUCTION IN PART OR WHOLE WITHOUT WRITTEN PERMISSION OF AQUACAL AUTOPILOT, INC., IS PROHIBITED.					
LTM0738			DWG. NO.		
SCALE 1:4	DWG SIZE A	REVISION DEV-F			
SHEET 1 OF 1			CAD FILE: LTM0350		

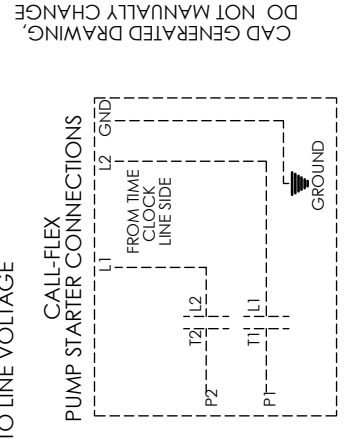

24VAC
 OPTIONAL LINE VOLTAGE
 FIELD WIRED LINE VOLTAGE

NOTES UNLESS OTHERWISE SPECIFIED:
 1. USE COPPER CONDUCTORS ONLY.
 2. TO BE WIRED IN ACCORDANCE WITH NAT'L ELEC (NEC) & LOCAL CODES.
 3. CONNECT TRANSFORMER TO CORRECT VOLTAGE.
 4. CUT RED WIRE ON PHASE ROTATION MONITOR FOR D-VOLT LINE VOLTAGE CODES:
 B: 208-230VAC/60HZ/3Ø
 D: 380-415VAC/50HZ/3Ø
 G: 460VAC/60HZ/3Ø

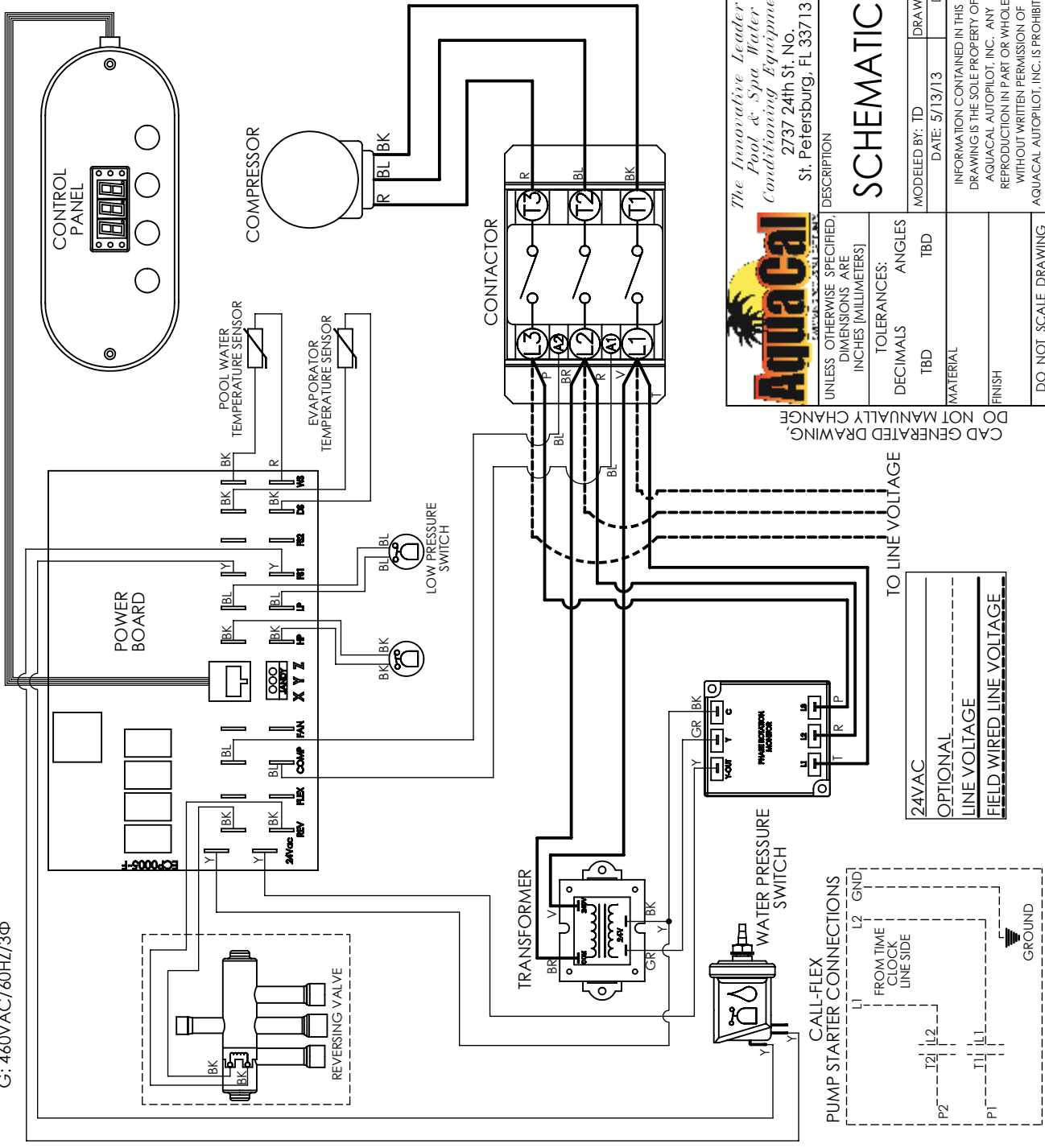

COLOR CODE

BL:	BLUE
BK:	BLACK
BR:	BROWN
BR/W:	BROWN AND WHITE
G:	GREEN
GR:	GRAY
P:	PINK
R:	RED
T:	TAN
V:	VIOLET
Y:	YELLOW
W:	WHITE



AUTOPILOT SYSTEMS, INC.
 SALT CHLORINE GENERATORS
 2737 24th St. No.
 St. Petersburg, FL 33713

SCHEMATIC, 3PH, WATERSOURCE

MODELED BY: TD	DRAWN BY: TD	DATE: 5/13/13	PROJECT ENG: TD	CHKD BY: TD
INFORMATION CONTAINED IN THIS DRAWING IS THE SOLE PROPERTY OF AQUACAL AUTOPILOT, INC. ANY REPRODUCTION IN PART OR WHOLE WITHOUT WRITTEN PERMISSION OF AQUACAL AUTOPILOT, INC., IS PROHIBITED.				
LIM0739			SCALE: 1:4	REVISION: DEV-G
DO NOT SCALE DRAWING			CAD FILE: LTM0333	SHEET 1 OF 1

UNLESS OTHERWISE SPECIFIED, DIMENSIONS ARE IN INCHES (MILLIMETERS)
 TOLERANCES:
 DECIMALS: TBD
 ANGLES: TBD
 MATERIAL: TBD
 FINISH: TBD
 DO NOT MANUALLY CHANGE CAD GENERATED DRAWING.

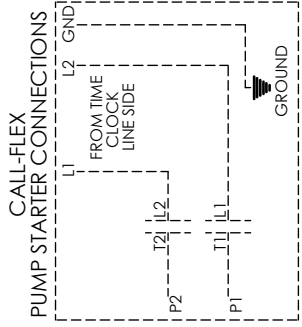

REVISION TABLE

REV.	PCA NUMBER/DESCRIPTION	CHANGED BY	DATE
DEV-D	ADDED COMPRESSOR CONTACTOR WIRES	TOMD	9/16/2014
DEV-E	ADDED REVERSING VALVE OPTION	TOMD	10/27/2014

1. 2. 3. 4. 5. 6. 7. 8.

5 - Troubleshooting

5.1 Fault Codes

A fault code indicates a specific issue or condition that will require action before the equipment can resume operating.

Please perform the following troubleshooting.

If the issue reoccurs, please see "*Contacting AquaCal AutoPilot, Inc.*" on page 1.

⚠ WARNING

Failure to heed the following may result in injury or death.

- Repairs must not be attempted by untrained or unqualified individuals.
- The heat pump contains refrigerant under high pressure. Repairs to the refrigerant circuit must not be attempted by untrained or unqualified individuals. Service must be performed only by qualified HVAC technicians. Recover refrigerant before opening the system.

NOTICE

Failure to heed the following may result in damage to equipment.

- Service by unauthorized personnel will void the heat pump warranty.

FLO Indicator

ISSUE

Low or no water detected.

RESOLUTION

1. Confirm the filter pump is on.
2. If a multiple-speed filter pump is being used, run at a higher speed to determine if the error persists. Do not exceed maximum flow rate for your model.
3. Confirm water is not being diverted away from the heat pump.
 - See "Water Flow Rates" on page 14.
 - See "Adjusting Water Flow Using ΔT (Delta-T)" on page 15.

F5 Indicator

ISSUE

The heat pump has sensed the coil is icing up.

RESOLUTION

CEr Indicator

ISSUE

This can indicate a loose or damaged communication cable.

RESOLUTION

A qualified technician should check the cable from control board to display assembly for a loose connection or visible damage.

CSE Indicator

ISSUE

This is a control system error.

RESOLUTION

Deactivate then reactivate power to reset controls.

dPC or dPD Indicator

ISSUE

Shorted or open defrost sensor.

RESOLUTION

A qualified technician should replace the defrost sensor.

PC or PD Indicator

ISSUE

Shorted or open water sensor.

RESOLUTION

A qualified technician should replace the water sensor.

HP Indicator

ISSUE

The refrigerant system's high-pressure switch is showing as open.

RESOLUTION

Heat Only Units and Heat and Cool (Reversing) Units

If the heat pump is a reversing unit, place it in **HEA** mode and perform the following troubleshooting.

Determine if an insufficient amount of water is being supplied to the equipment.

1. Confirm the filter pump is on.
2. If a multiple-speed filter pump is being used, run filter pump at a higher speed. Do not exceed maximum flow rate for the model.
3. Confirm water is not being diverted away from the heat pump.
 - See "Water Flow Rates" on page 14.
 - See "Adjusting Water Flow Using ΔT (Delta-T)" on page 15.
4. The water pressure switch may be incorrectly calibrated. See "Adjusting Water Pressure Switch" on page 16.

A qualified HVAC technician should evaluate the system for the following:

1. The high-pressure switch may be defective. Replace the switch.
2. The heat pump may have too high a refrigerant charge. See heat pump data plate for correct charge. Then use a temperature pressure chart to confirm charge.

Please note – Improperly charging the system can void manufacturer's warranty.

Cool Only Units

Determine if an insufficient amount of air is being supplied to the equipment.

1. Check for proper fan operation. If fan is not operating, contact AquaCal®.
2. Check for obstructed air flow around the heat pump. See "Clearances" on page 5.
3. Check for dirty or blocked evaporator coil. See "Cleaning Equipment After Installation" on page 29.

A qualified HVAC technician should evaluate the system for the following:

1. The high-pressure switch may be defective. Replace the switch.
2. The heat pump may have too high a refrigerant charge. See heat pump data plate for correct charge. Then use a temperature pressure chart to confirm charge.

Please note – Improperly charging the system can void manufacturer's warranty.

If the heat pump is a reversing unit, place it in **HEA** mode and perform the following troubleshooting.

Determine if an insufficient amount of water is being supplied to the equipment.

1. Confirm the filter pump is on.
2. If a multiple-speed filter pump is being used, run filter pump at a higher speed. Do not exceed maximum flow rate for the model.
3. Confirm water is not being diverted away from the heat pump.
 - See "Water Flow Rates" on page 14.
 - See "Adjusting Water Flow Using ΔT (Delta-T)" on page 15.
4. The water pressure switch may be incorrectly calibrated. See "Adjusting Water Pressure Switch" on page 16.

HP5 Indicator

ISSUE

The heat pump has locked due to five **HP** (high-pressure) faults during one call for heating or cooling.

RESOLUTION

1. Deactivate then reactivate power to the heat pump to clear error.
2. Troubleshoot the high-pressure issue causing the error. See "HP Indicator" on page 53.

LP Indicator

ISSUE

The refrigerant system's low-pressure switch is showing as open.

RESOLUTION

If the heat pump is a reversing unit, place it in **HEA** mode and perform the following troubleshooting.

Determine if an insufficient amount of water is being supplied to the equipment.

1. Confirm the filter pump is on.
2. If a multiple-speed filter pump is being used, run filter pump at a higher speed. Do not exceed maximum flow rate for the model.
3. Confirm water is not being diverted away from the heat pump.
 - See "Water Flow Rates" on page 14.
 - See "Adjusting Water Flow Using ΔT (Delta-T)" on page 15.
4. The water pressure switch may be incorrectly calibrated. See "Adjusting Water Pressure Switch" on page 16.

LP5 Indicator

ISSUE

The heat pump has locked due to five **LP** (low-pressure) faults during one call for heating or cooling.

RESOLUTION

1. Deactivate then reactivate power to the heat pump to clear error.
2. Troubleshoot the low-pressure issue causing the error. See "LP Indicator" on page 54.

DEA Indicator

ISSUE

Incoming water temperature exceeded 110° F and the unit is locked with an **DEA** over temperature alarm. The heat pump will not operate until incoming water temperature drops to 100° F or lower.

RESOLUTION

1. Determine if another heat source (gas heater, solar heater, etc.) is heating water being sent directly to the heat pump with the **DEA** indicator. This situation will need to be corrected before continuing.
2. Rule out an incorrect reading from the water temperature sensor. Verify existing water temperature with an accurate thermometer. If heat pump's sensor is inaccurate, the water temperature sensor may require replacement.

5.2 Issues and Resolutions

WARNING

Failure to heed the following may result in injury or death.

- Repairs must not be attempted by untrained or unqualified individuals.
- The heat pump contains refrigerant under pressure. Repairs to the refrigerant circuit must not be attempted by untrained or unqualified individuals. Service must be performed only by qualified HVAC technicians. Recover refrigerant before opening the system.

NOTICE

Failure to heed the following may result in damage to equipment.

- Service by unauthorized personnel will void the factory warranty.

Please perform the following troubleshooting.

For further assistance, please see "*Contacting AquaCal AutoPilot, Inc.*" on page 1.

Display Panel Not Responding

1. If the heat pump is controlled by an external controller, confirm the external controller settings. See "Operating Heat Pump (With an External Controller)" on page 37.
2. If the issue is still occurring, disconnect external controller from the heat pump. Then check operation at heat pump.
 - If display panel responds, the problem lies with the external controller or its installation. Contact the manufacturer of the external control device.

Heat Pump Not Running

1. Confirm equipment is receiving power. Is the heat pump display illuminated?
 - If not, confirm the main breaker (located at the power supply panel) and the disconnect switch (located near the heat pump) are both turned on.
 - If the display still does not illuminate, it is recommended that the heat pump installer or electrician confirms heat pump is receiving power.
2. Confirm correct mode is selected. See "Setting Operating Mode" on page 34.
3. Confirm thermostat is set correctly. See "Setting Thermostats" on page 35.
 - When heating the water is desired, the thermostat should be set above the current water temperature.
 - When cooling the water is desired, the thermostat should be set below the current water temperature.
4. If an error code is displayed, diagnose and correct the cause of the code. See "Fault Codes" on page 52.
5. If the heat pump is using an external controller, the heat pump may not be set correctly to accept the controller's signal.
 - See "Connecting an External Controller" on page 23.
 - See "Operating Heat Pump (With an External Controller)" on page 37.

Heat Pump's Tripping Breaker

1. Have an electrician confirm breakers are in good condition and properly sized for the heat pump.
2. Multiple heat pumps installed at the same site may benefit from special automatic sequencing controllers to avoid excessive power drops at start-up. See "Automatic Sequencing Controller" on page 44.
3. If a fault occurs immediately when the compressor starts, a qualified technician should evaluate the system.

Heat Pump Won't Shut Off

PLEASE NOTE

When heat pump is set to "OFF", the display will show either the water temperature or FLD.

1. Confirm the heat pump has reached the desired temperature set on the thermostat. The heat pump will continue to run until the set temperature is reached.
2. If the heat pump is using an external controller, it may not be set correctly.
 - See "Operating Heat Pump (With an External Controller)" on page 37.

Heat Pump Is Running, Not Heating

1. If the heat pump is using an external controller, confirm it is set correctly.
 - See "Operating Heat Pump (With an External Controller)" on page 37.
 - If the heat pump is still not running correctly with this device, contact the installer of the external controller device or the device's manufacturer for further assistance.
2. Confirm heat pump mode is set to **HEA** operating mode.
3. Confirm thermostat is set to the desired water temperature.
4. Confirm valves are correctly positioned to heat the correct body of water (either the pool or the spa). If heating a spa that overflows into a pool, confirm the spa is isolated when being heated (not flowing into the pool).
5. Confirm heat pump is transferring heat into the water.
 - Measure the pool-side and source-side discharge water coming out of the heat pump. See "Adjusting Water Flow Using ΔT (Delta-T)" on page 15.
6. If an error code is displayed, diagnose and correct cause of code. See "Fault Codes" on page 52.
7. Confirm that filter pump has a sufficient run-time. The heat pump will not run (or heat the water) without water flow. Water Source equipment will generally be set to run 24 hours a day in commercial applications. See "Heating Recommendations" on page 43.
8. If heating a spa, deactivate air blower or venturi (if equipped) to allow for quicker heating times. For pools, deactivate water features, such as slides, waterfalls, or fountains to allow water to retain heat. Use of a liquid pool blanket product, such as an Aqua Blanket™, can also compensate for excessive heat loss. See "Liquid Blankets" on page 44.

Heat Pump Is Running, Not Cooling (Reversing Models)

1. If the heat pump is using an external controller, confirm the heat pump is programmed properly to allow for cooling. See "Operating Heat Pump (With an External Controller)" on page 37.
2. Confirm the heat pump mode is set to **COO** operating mode.
3. Confirm the thermostat is set below the current water temperature.
4. Confirm valves are correctly positioned to cool the correct body of water (either the pool or the spa). If cooling a spa that overflows into a pool, confirm the spa is isolated when being cooled (not flowing into the pool).
5. If an error code is displayed, determine and correct the condition causing the code. See "Fault Codes" on page 52.
6. Confirm heat pump is transferring heat out of the water.
 - Measure the temperature of source-side and pool-side discharge water coming out of heat pump. See "Adjusting Water Flow Using ΔT (Delta-T)" on page 15.
7. Confirm that filter pump has a sufficient run-time. The heat pump will not run (or cool the water) without water flow. Water Source equipment will generally be set to run 24 hours a day in commercial applications. See "Cooling Recommendations" on page 43.