

# AquaCal®

## Installation Manual

**TropiCool**  
WATER CHILLER

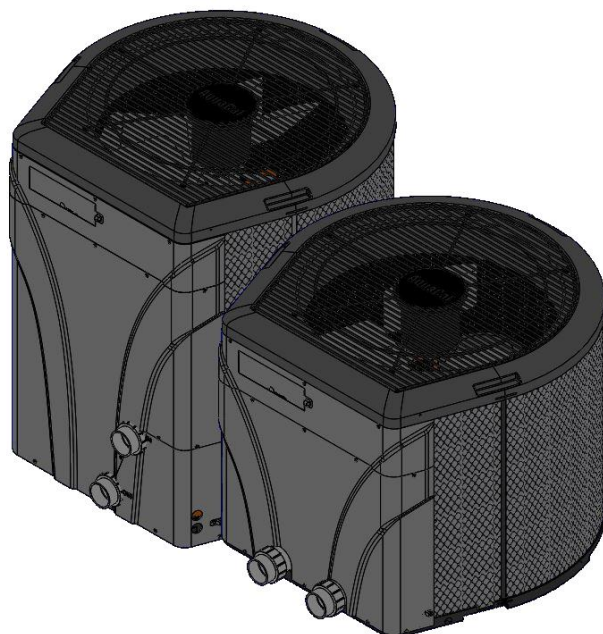

### Important

Read this document before operating / installing this product

For additional product manuals and operation / installation procedures, please visit [www.AquaCal.com](http://www.AquaCal.com)

\_\_\_\_\_

MODEL / SERIAL NUMBER

# Table of Contents

---

## **Section 1 - Contacting AquaCal AutoPilot, Inc.**

## **Section 2 - Safety**

## **Section 3 - Installation**

3.1 Dimensions .....	2
3.2 Positioning Equipment .....	3
3.3 Plumbing .....	3
3.3.a Clearances .....	3
3.3.b Water Flow Rates .....	4
3.3.c Adjusting Water Flow Using $\Delta T$ (Delta-T) .....	5
3.3.d Plumbing Requirements .....	6
3.3.e Plumbing Diagrams .....	6
3.3.f Water Connections to Chiller .....	7
3.3.g In-Line Chlorine Feeders .....	8
3.3.h Maintaining Ability to Winterize .....	8
3.3.i Adjusting Water Pressure Switch .....	8
3.4 Electrical .....	9
3.4.a Electrical Requirements .....	9
3.4.b Electrical Knockouts .....	10
3.4.c Access Panels .....	11
3.4.d Schematics .....	11
3.4.e Verifying Transformer Setting .....	11
3.4.f Three-Phase Adjustment .....	12
3.4.g Connecting Chiller to an External Controller .....	12
3.5 Service Level Programming .....	14

## **Section 4 - Operation**

4.1 Energizing Chiller .....	18
4.2 Display Door .....	18
4.3 Display Lock .....	18
4.4 Display Panel .....	18
4.4.a Buttons .....	18
4.4.b Indicator Lights .....	19
4.4.c Display .....	19

---

4.5 User Level Factory Defaults .....	20
4.6 Setting Operating Mode .....	20
4.7 Selecting Celsius or Fahrenheit .....	21
4.8 Setting Thermostats .....	21
4.9 User Lock Option (Enable) .....	22
4.10 User Lock Option (Disable) .....	23
4.11 User Lock Option (Entering Pass Code) .....	23
4.12 Operating Chiller (With an External Controller) .....	24
<b>Section 5 - Maintenance</b>	
5.1 Water Chemistry .....	25
5.2 Cleaning Equipment After Installation .....	25
5.3 Planned Maintenance .....	26
5.4 Winterizing .....	27
<b>Section 6 - Troubleshooting</b>	
6.1 Fault Codes .....	28
6.2 Issues and Resolutions .....	30
<b>Section 7 - Appendix</b>	
7.1 Identifying Model Specifications .....	33
7.2 Weights .....	34
7.3 Initial Cooling Recommendations .....	34
7.4 Available Accessories .....	34

## SECTION 1 - CONTACTING AQUACAL AUTOPILOT, INC.

For further assistance, please contact AquaCal AutoPilot, Inc. Technical Support. To better assist you, please have the chiller model and serial number available. See "Identifying Model Specifications" on page 33.

<b>Website</b>	www.AquaCal.com
<b>Request Service Online</b>	<a href="http://www.AquaCal.com/request-heat-pump-service/">www.AquaCal.com/request-heat-pump-service/</a>
<b>Phone</b>	(1) 727-823-5642
<b>Hours</b>	8-5 pm, Eastern M-F

## SECTION 2 - SAFETY

- For personal safety, and to avoid damage to equipment, follow all safety instructions displayed on the equipment and within this manual. Repair and service of chiller must be performed by an authorized service center.
- Warranties may be voided if the equipment has been improperly installed, maintained or serviced.
- If service is deemed necessary, please contact AquaCal® Technical Support. See "Contacting AquaCal AutoPilot, Inc." on page 1.

### **SAFETY SIGNALS**

*Throughout this document, safety signals have been placed where particular attention is required.*



**WARNING** - signals relate to personal safety.



**CAUTION** - signals promote avoiding damage to the equipment.

When installing and using your chiller basic safety precautions must always be followed, including the following:

- ⚠ **WARNING** - Failure to heed the following may result in injury or death.
  - Installation and repairs must be performed by a qualified technician.
  - The chiller contains refrigerant under pressure. Repairs to the refrigerant circuit must not be attempted by untrained and / or unqualified individuals. Service must be performed only by qualified HVAC technicians. Recover refrigerant before opening the system.
  - The chiller utilizes high voltage and rotating equipment. Use caution when servicing.
  - Electrical installation and service should be performed by a Licensed Electrician only.
  - Improper water chemistry can present a serious health hazard. To avoid possible hazards, maintain pool / spa water per standards detailed in this document.
  - Prolonged immersion in water colder than normal body temperature may cause a condition known as Hypothermia. The symptoms of Hypothermia include shivering (although as hypothermia worsens, shivering stops), clumsiness or lack of coordination, slurred speech or mumbling, confusion and poor decision-making, drowsiness or low energy, lack of concern about personal welfare, progressive loss of consciousness, weak pulse and slow or shallow breathing. In addition, persons having an adverse medical history, or pregnant women, should consult a physician before immersing in a cold body of water. Children and the extreme elderly should be supervised by a responsible adult.
- ⚠ **CAUTION** - Failure to heed the following may result in equipment damage.
  - Maintain proper water chemistry in order to avoid damage to pump, filter, pool shell, etc.
  - Water flow exceeding maximum flow rate requires a bypass. Damage due to excessive water flow will void warranty.

**SAVE THESE INSTRUCTIONS**

## SECTION 3 - INSTALLATION

**⚠ WARNING** - Failure to heed the following may result in injury or death.

- Installation of this equipment by anyone other than a qualified installer can result in a safety hazard. The information contained throughout the "Installation" section is intended for use by qualified installation technicians familiar with the swimming Pool / Spa safety standards.

**⚠ CAUTION** - Failure to heed the following may result in equipment damage.

- Failure to protect equipment against corrosive conditions will adversely affect the life of the equipment and will void equipment warranty.

### 3.1 Dimensions

#### Dimensions (TropiCool® TC500)

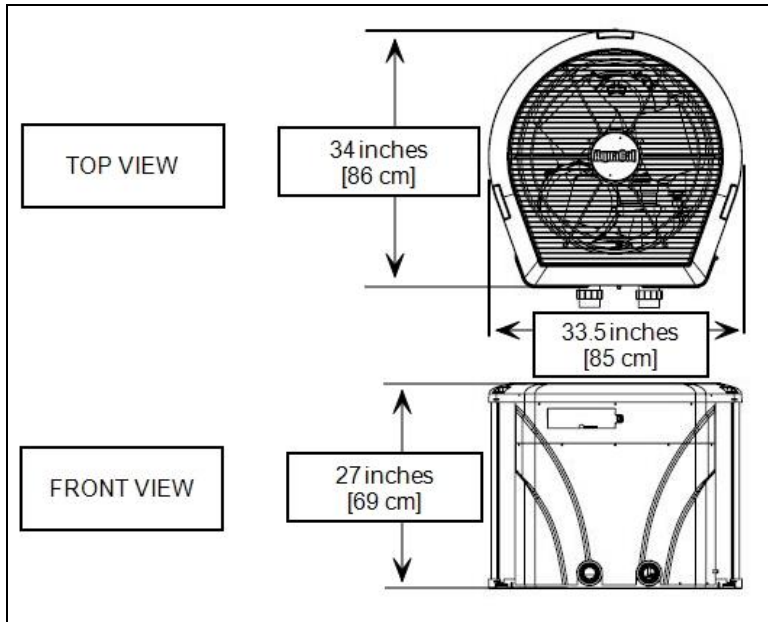

#### Dimensions (TropiCool® TC1000)

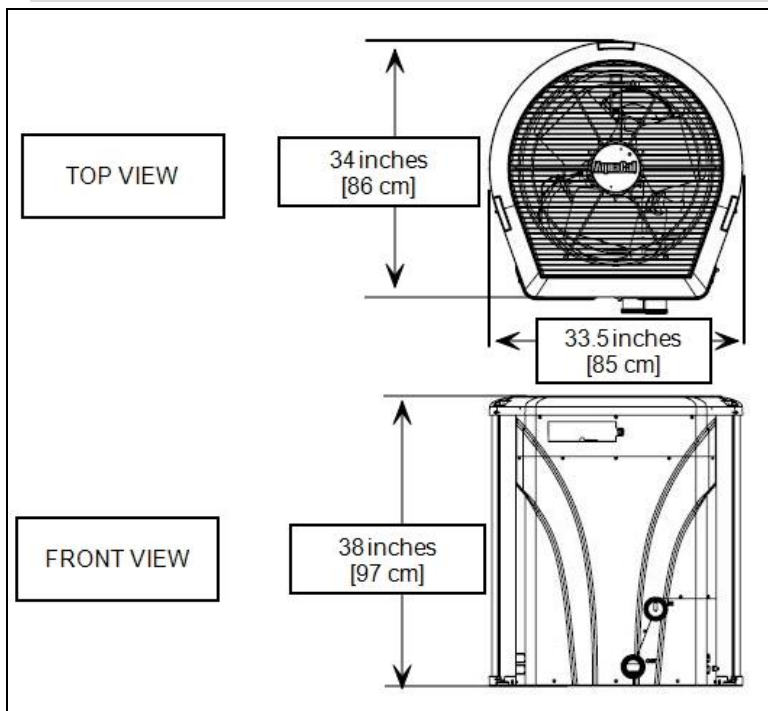

## 3.2 Positioning Equipment

### Controlling Irrigation and Rainwater Runoff

- Irrigation water may damage chiller components. Have irrigation water directed away from the chiller.
- The chiller will withstand normal rainfall. Do not allow a roof slope to direct rainwater onto the chiller. Have a gutter installed on the roof edge to direct this water away from the chiller. Or install the chiller in another location.

### Planning for Condensation

The chiller can produce a large amount of water in the form of condensation. The amount of water depends on air temperature and humidity.

- Install the chiller with enough height to allow for water drainage.
- Plan for water drainage disposal as needed.

### Mounting Pad Requirements

- Build the chiller pad out of concrete or another code-approved material.
- Confirm the pad can support the weight of the chiller. See "Weights" on page 34.
- Elevate the pad enough to allow for drainage.
- Make sure the pad is flat and level.
- Have the pad extend at least 6 inches from the chiller base in all directions.
- Do not install the chiller on soil or grass.
- Do not allow the chiller base to touch the buildings foundation.
- Do not place the chiller directly on a concrete floor inside a building. This can cause noisy equipment vibration. Install vibration dampeners between the chiller base and floor.
- Equipment pad must meet all requirements of authorities having code-related jurisdiction.

### Anchoring to Pad

- Follow all applicable local, state, and national requirements regarding wind load anchoring.
- The shipping brackets used to tie the chiller to the pallet are approved mounting (hurricane) brackets. They can be used to anchor the chiller to the pad.
- If needed, contact AquaCal® Customer Support to obtain the correct anchoring kit information. Please have the chiller model number and serial number when requesting support. See "Identifying Model Specifications" on page 33.

## 3.3 Plumbing

### 3.3.a Clearances

- Proper air circulation is required for the chiller to operate efficiently. Avoid placing objects near or on top of the chiller. This includes shrubbery and lawn furniture. These objects will also hinder maintenance access.
- Avoid storing chemical containers near the chiller. The chemicals can cause equipment damage.

### Overhead Clearance

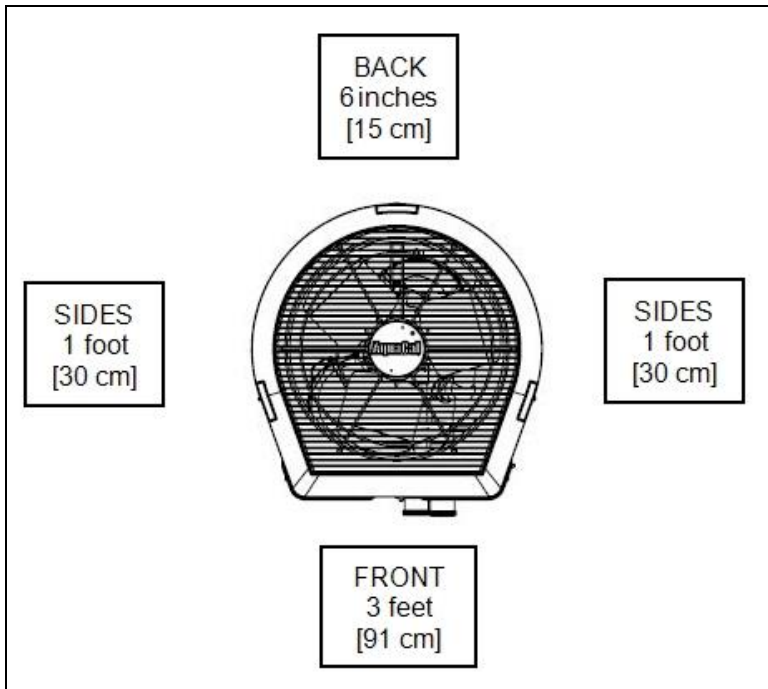
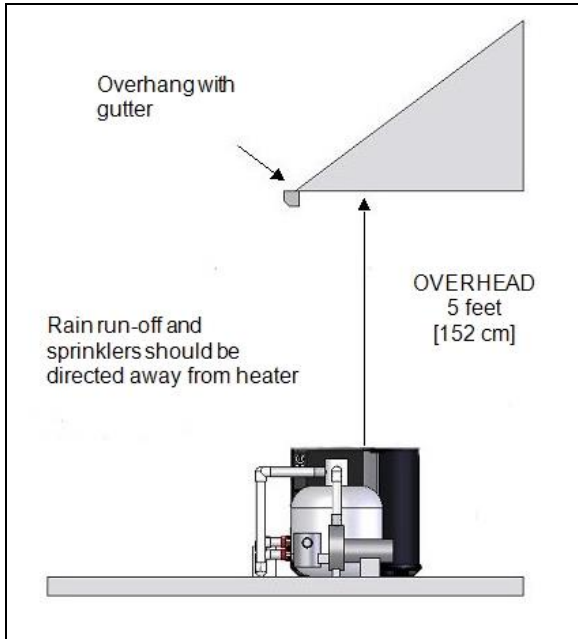

### 3.3.b Water Flow Rates

Maintain water flow rates as indicated. Please note, these specifications relate to the chiller only. Code-specified whole system turnover rates must be satisfied.

**⚠ CAUTION** - Failure to heed the following may result in equipment damage.

- Water flow exceeding maximum flow rate may damage heat exchanger; such damage will not be covered under the equipment warranty

MODEL	HEAT EXCHANGER TYPE	FLOW RATES	
		MINIMUM	MAXIMUM
TC500	Titanium Tube-in-Tube	20 GPM	45 GPM
TC1000	Titanium ThermoLink®	30 GPM	70 GPM

If water flow through the chiller is reduced, performance will suffer and internal safety devices may deactivate the chiller with error codes **LP** or **LPS** (if equipped).

- Operate water filtration devices per manufacturer's specifications. Dirty filters can cause reduced water flow to the chiller. An increase of 7-10 psi higher than the clean filter pressure typically reduces flow rates. This requires the filter to be cleaned or back-washed
- Keep baskets free of debris. Similar to a dirty filter, large volumes of debris in the pump and skimmer baskets can reduce water flow.
- Check for improper valve settings. A partially closed valve after the filter, or a full-open bypass around the chiller, will cause insufficient water flow through the chiller.
- The maximum static (or operating pressure) is 50 pounds-per-square-inch (PSI). These specifications relate to the chiller only. Code-specified whole system turnover rates must be satisfied.

### 3.3.c Adjusting Water Flow Using $\Delta T$ (Delta-T)

The Delta-T is the temperature difference between the water temperatures entering and leaving the chiller. The equipment can be fine-tuned for maximum performance by balancing water flow rates to maintain an ideal  $\Delta T$ .

- Installed Temperature / Pressure probes and ports are required to perform the following procedures.
- **This adjustment procedure is to be completed with the unit in HEA mode only;** ACH and CDD discharge temperatures are not shown.

#### **PLEASE NOTE -**

*Temperature / Pressure ports are required for all commercial applications.*

*They are strongly recommended (but not required) for residential installations.*

1. Adjust chiller thermostat to its lowest setting while in **HEA** mode.
2. Deactivate the water filtration pump.
3. Adjust valves to a halfway open position leading to the chiller.
4. Adjust valves to a fully open position leading away from the chiller.
5. Activate the pool water filtration pump.
6. Slowly turn the thermostat up until the chiller activates.
  - After a four-minute delay, the chiller compressor will start.
7. With the chiller running, confirm water filtration pump is operating properly with adequate flow and no short cycling. If needed, clean filters leading to the chiller.
8. Wait for water and refrigerant pressure to stabilize (approximately 5 minutes).
9. Adjust valves in the following order:
  - A. Adjust valve leading away from the chiller to correct temperatures measured with a temperature pressure probe.
  - B. Allow pressure to stabilize. Then check temperature again. Re-adjust valve leading away from the chiller as needed.
10. Mark valves at these positions for future reference.

**Temperature / Pressure Port  
(Shown with Probe)**





Temperature differences are based on pool temperatures of 72° (+ or – 3° F). For water temperatures outside this range, contact AquaCal® Technical Support.

MODEL	TEMPERATURE
TC500	2° to 5° F
TC1000	2° to 5° F

Table 1 - Temperature Chart

### 3.3.d Plumbing Requirements

**⚠ CAUTION** - Failure to heed the following may result in equipment damage.

- Do not use glue on the threaded portion of the equipment's unions. A glued-in-place union will prevent the equipment from being properly winterized.
- The chiller must receive water flow within the specified minimum ranges under worst-case conditions such as a fouled water filter.
- Water flow exceeding maximum flow rates may damage chiller and will not be covered under equipment warranty. See "Water Flow Rates" on page 4.
  - Install a bypass valve whenever water-flow may exceed maximum rating.
    - See "5 lb Bypass Valve Kit (Kit STK0135)" on page 34.
    - For additional guidance testing water flow rates, please contact AquaCal® Technical Support.

### 3.3.e Plumbing Diagrams

Plumbing diagrams are provided in this section as a planning guide to the sequence of equipment, valves, and fittings.

- The basic plumbing configurations for typical installations are shown.
- If the installation does not closely follow any of the supplied plumbing diagrams, AquaCal® Technical Support is available for installation advice and guidance.

#### Air Source Chiller Plumbing Diagrams

**Chiller with water flows equal or less than maximum listed flow rate**

See "Water Flow Rates" on page 4.

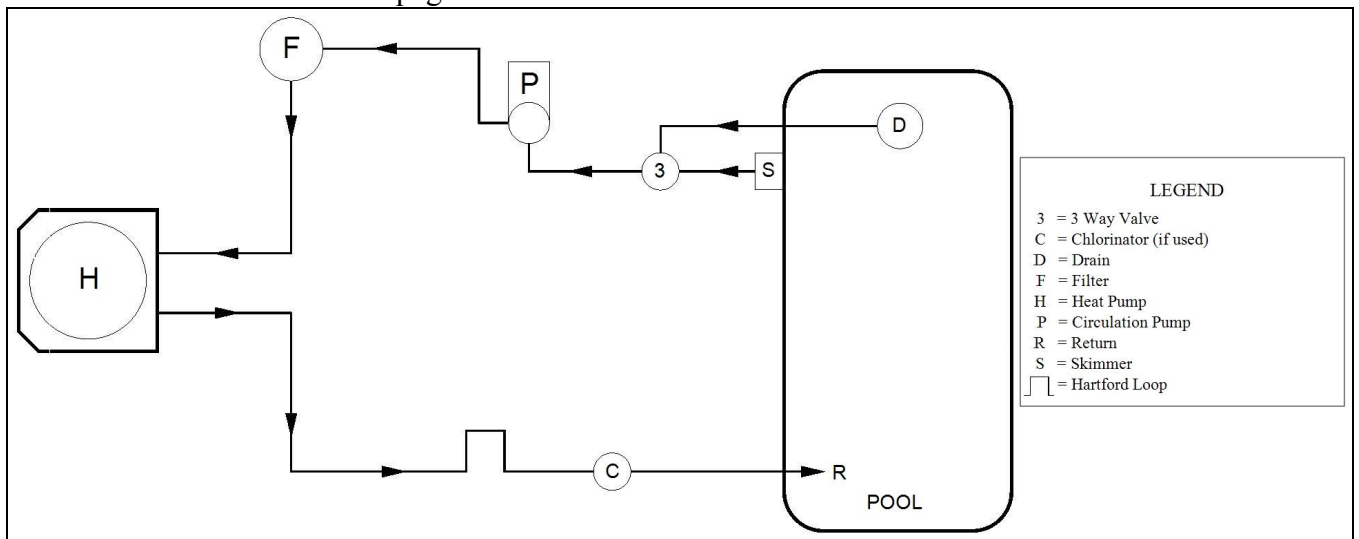

**Chiller with water flows greater than maximum listed flow rate**  
 See "Water Flow Rates" on page 4.

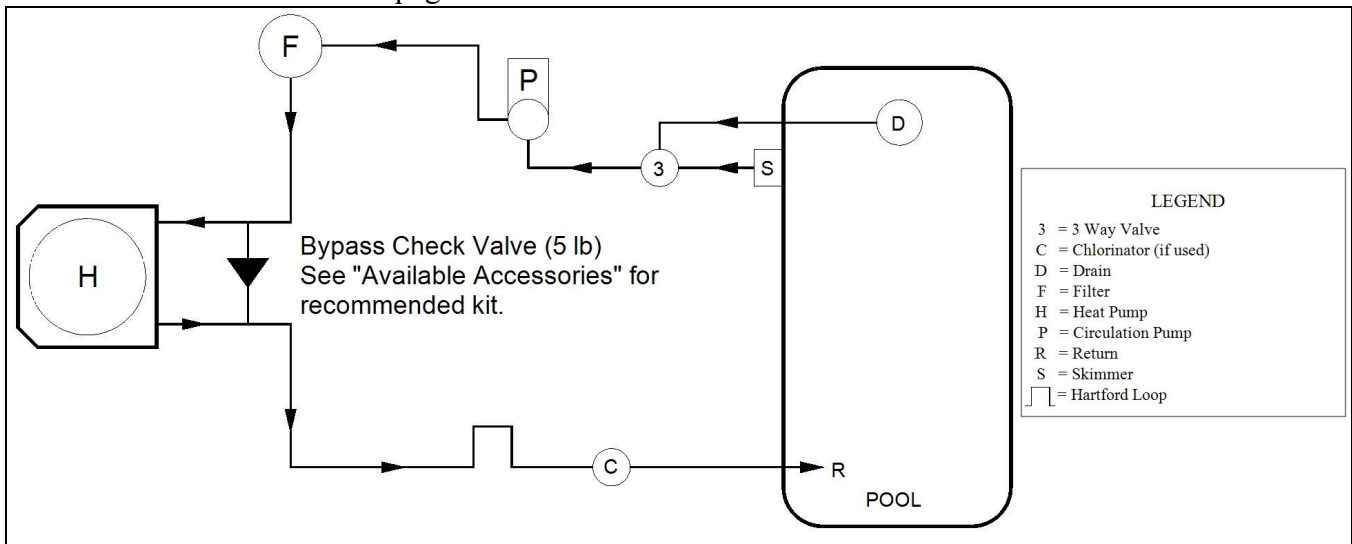

**3.3.f Water Connections to Chiller**

- Connections to site plumbing are made via PVC solvent cement to the female slip socket of the plumbing unions.
- Chiller union sizes are specified on diagrams.
- Plumbing unions are available from AquaCal®. See "Available Accessories" on page 34.

**⚠ CAUTION** - Failure to heed the following may result in equipment damage.

- Do not use glue on the threaded portion of the equipment's unions. A glued-in-place union will prevent the equipment from being properly winterized.

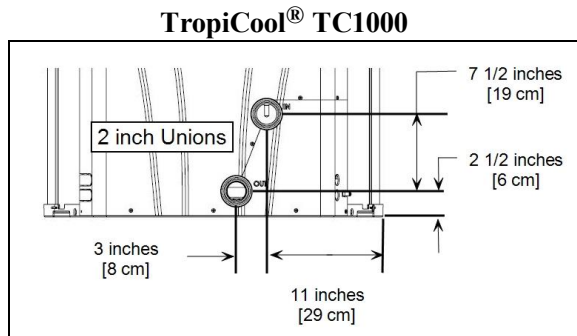
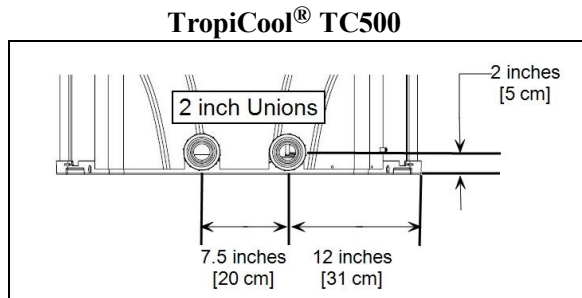

### 3.3.g In-Line Chlorine Feeders

Place in-line chlorinators downstream from the chiller and as low in elevation as possible. If an erosion type feeder is used, always install a Hartford Loop to protect internal chiller components.

**Chiller with Hartford Loop**

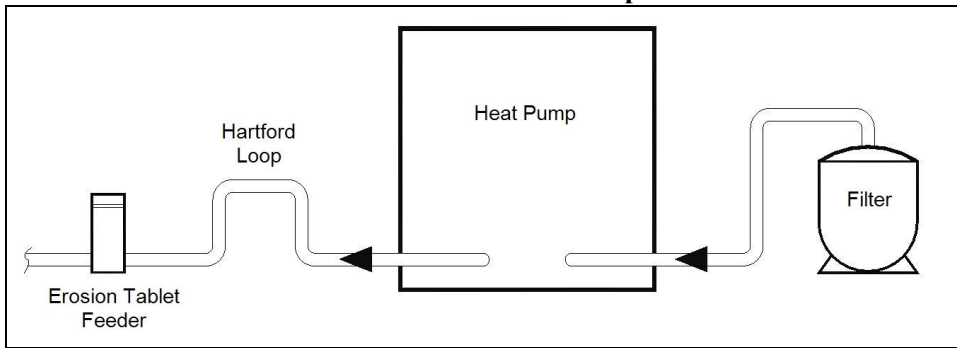

### 3.3.h Maintaining Ability to Winterize

**⚠ CAUTION** - Failure to heed the following may result in equipment damage.

- Do not use glue on the threaded portion of the equipment's unions. A glued-in-place union will prevent the chiller from being properly winterized.

The unions can be used to decouple the chiller from the plumbing system during hard freeze conditions. Do not defeat the function of the unions by using glue on the threaded portion of the unions. See "Winterizing" on page 27.

### 3.3.i Adjusting Water Pressure Switch

Adjust water pressure switch when chiller attempts to operate without water flow.

**⚠ WARNING** - Failure to heed the following may result in injury or death.

- Water Pressure Switch adjustment procedure to be performed by experienced service personnel only; procedure must not be attempted by individuals lacking adequate electrical and mechanical experience.

**⚠ CAUTION** - Failure to heed the following may result in equipment damage.

- If after water pressure switch adjustment the chiller continues to operate with the filter pump off, readjust water pressure switch to ensure chiller will not run without water flow.

**Confirm the following before attempting any adjustments:**

- The filter is clean.
- Filter pump is operating.
- Valves are set to direct appropriate amount of water through the chiller. See "Water Flow Rates" on page 4.
- **FLD** code is displayed (or displays intermittently).

### Adjusting Water Pressure Switch:

1. Remove chiller access panel. See "Access Panels" on page 11.
2. Locate the water pressure switch. It will be outside and along the bottom edge of the electrical enclosure. Exact location varies by model.
3. Activate filter pump.
4. Apply power to chiller.
5. Slowly rotate adjustment wheel on switch until the **FLD** code just disappears.
6. Deactivate filter pump. If correctly adjusted, the chiller will deactivate and display **FLD**.
7. Re-install chiller access panel.
  - If chiller continues to operate without water flow, contact AquaCal® Technical Support.
  - Site-specific factors may require the installation of an external flow switch. See "Available Accessories" on page 34.

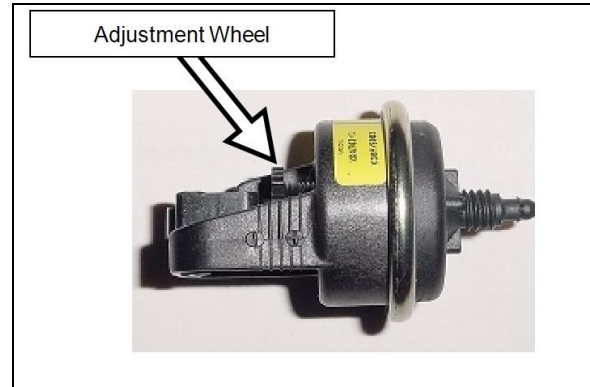

## 3.4 Electrical

### 3.4.a Electrical Requirements

- ⚠ WARNING** - Failure to heed the following may result in injury or death.
- The information contained in this section is intended for use by qualified electricians familiar with electrical service-industry safety standards and methods.
  - Locate the equipment disconnect as near to the chiller as possible. Always satisfy applicable codes and standards.
  - Never mount power-disconnects directly to the chiller.
  - In sizing power wiring, be especially aware of up-sizing requirements necessary due to wiring distances. Always satisfy applicable codes and standards.
  - Multiple chillers installed at the same site may benefit from automatic sequencing controllers (ASC) to avoid excessive power drops at start-up. See "Available Accessories" on page 34.
  - AquaCal® chillers are designed to use copper conductors, only. Do not use aluminum wire.

## Electrical Standards

Standards	Title
<b>NFPA 70</b>	The electrical installation must conform to the current version of the NEC, and all applicable local and state codes
<b>NFPA 70 Article 440</b>	Standard for Safety for Electric Spas, Equipment Assemblies, and Associated Equipment
<b>NFPA 70 Article 680</b>	Standard for Safety for Swimming Pool Pumps, Filters, and Chlorinators
<b>IEC 60335-1-2001</b>	Household and similar electrical appliances - Safety - General Requirements
<b>IEC 60335-2-40 2006</b>	Household and similar electrical appliances - Safety – Particular requirements for electrical heat pumps, air-conditioners, and dehumidifiers
<b>UL1995 &amp; CSA C22.2 236-05</b>	Heating and cooling equipment

Table 2 - Standards

## Grounding and Bonding

Follow local code requirements for properly grounding and bonding chiller equipment.

- A bonding lug has been provided on the lower right hand corner of the front panel.

## Surge Suppression

The use of approved commercial surge protectors is strongly recommended.

## Sizing the Electrical Service

Refer to equipment data plate for specific information required to size electrical service and over-current protection of chiller. Sizing is based on data plate information, wire size, wiring devices, and over-current protection per applicable local codes and standards. See "Identifying Model Specifications" on page 33.

### 3.4.b Electrical Knockouts

**TC500**

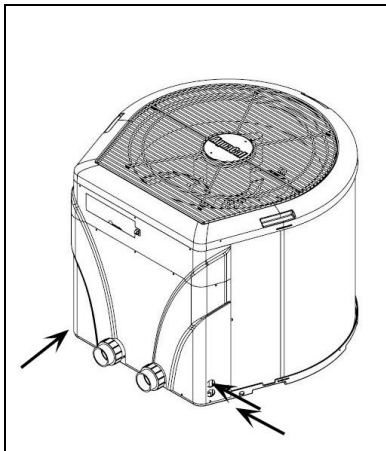

**TC1000**

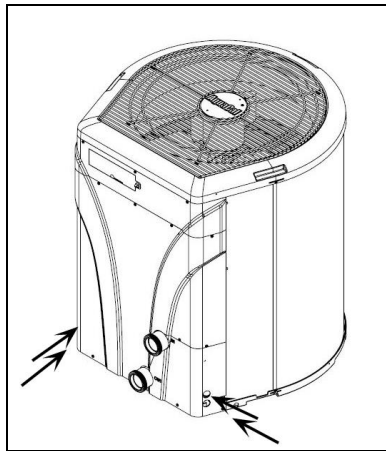

### 3.4.c Access Panels

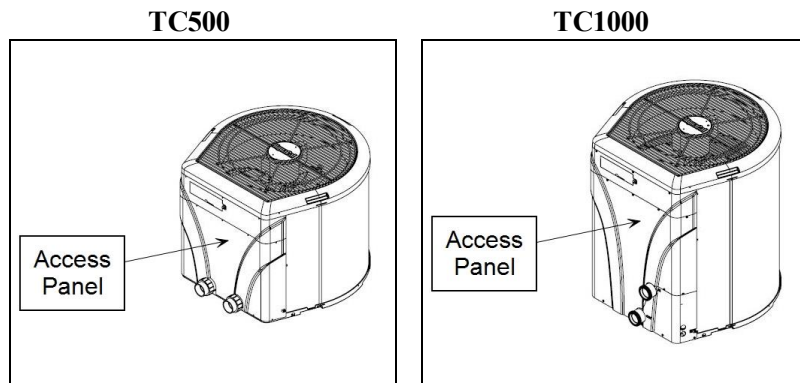

### 3.4.d Schematics

Schematics are located on the inside of the equipment access panel.

**PLEASE NOTE:**

- Specifications are subject to change without notice.
- Schematics are available by calling AquaCal® Customer Support.
  - Please have the complete model and serial number available.
  - See "Identifying Model Specifications" on page 33.

### 3.4.e Verifying Transformer Setting

Transformer voltage settings must be confirmed and set correctly depending on the measured voltage found on the site. Incorrect settings may cause chiller damage. The following procedure will allow the installer to set the chiller's transformer for the appropriate site voltage.

**⚠ WARNING** - Failure to heed the following may result in injury or death.

- The information contained in this section is intended for use by qualified electrical installation technicians, familiar with electrical service-industry safety standards and methods.

**⚠ CAUTION** - Failure to heed the following may result in equipment damage.

- Setting a voltage other than what is listed on the chiller's data plate can damage equipment and is not covered under warranty.
1. Turn chiller on by adjusting the thermostat to call for cooling. If more than one chiller is on site, turn them all on. Final adjustments must be made with all chillers running.
  2. Measure the running site voltage.
  3. Confirm transformer tap is set for the measured site voltage. If more than one voltage tap is shown, select the voltage nearest to the running site voltage.

**Example of chiller transformer  
(Varies between models)**

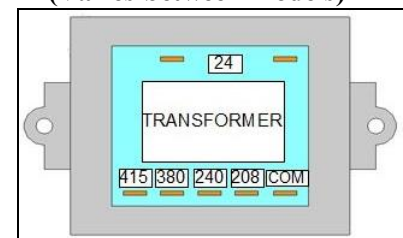

Please note: If more than one voltage is shown on the equipment's data plate, the factory default setting is usually the higher voltage on the transformer. As an example, a "208/230" voltage will be set to "240" from the factory.

### 3.4.f Three-Phase Adjustment

If a three-phase unit fails to operate at start up, the orientation of the line voltage "field" wiring may need to be adjusted.

**⚠ WARNING** - Failure to heed the following may result in injury or death.

- The information contained in this section is intended for use by qualified electrical installation technicians, familiar with electrical service-industry safety standards and methods.

**⚠ CAUTION** - Failure to heed the following may result in equipment damage.

- Setting a voltage other than what is listed on the chiller's data plate can damage equipment and is not covered under warranty.
1. Deactivate power to the unit. **Confirm that power is off to all three legs using an electrical test meter set for the correct voltage.**
  2. Switch position of the incoming power wires at each leg as follows, re-connect power, and attempt to restart the unit. If the unit fails to start, disconnect power. Verify off and proceed to next leg.
    - Switch incoming power wires at L1 and L2 on the line side to the contactor.
    - Switch incoming power wires at L1 and L3 on the line side to the contactor.
    - Switch incoming power wires at L2 and L3 on the line side to the contactor.
  3. When chiller starts, disconnect power and verify off. Then confirm all line voltage connections are securely tightened. Reconnect power.
    - If chiller does not start, contact AquaCal® Technical Support.

### 3.4.g Connecting Chiller to an External Controller

To support a direct connection to an external controller, AquaCal® chillers are equipped with optional terminal blocks. These terminals are on the microprocessor located on the low-voltage side of the electrical enclosure.

**⚠ WARNING** - Failure to heed the following may result in injury or death.

- This section is only for qualified installers who are familiar with swimming pool and spa safety standards.
- The installer must be familiar with service industry techniques.
- Deactivate power while routing wiring to control board.

**⚠ CAUTION** - Failure to heed the following may result in equipment damage.

- The wire size connecting the controller must be 16-gauge, 2-conductor or larger, low-voltage wire.
- Use direct connection (**dry contact**) provided on the microprocessor for external controllers.

Please confirm the type of external controller to be installed and follow the appropriate instructions.

- A **two-wire** controller (**with an internal thermostat**). *The user can set and adjust the temperature at the controller's screen.*
- A **three-wire** controller (**with an "OFF" position**). *The user adjusts the temperature at the heat pump. The user can select pool or spa mode or turn off the heat pump using the controller.*
- A **three-wire** controller (**without an "OFF" position**). *The user adjusts the temperature at the heat pump. The user can select pool or spa mode, but must turn off the heat pump at the heat pump display panel.*

#### Dry Contact Connection Points to the Microprocessor

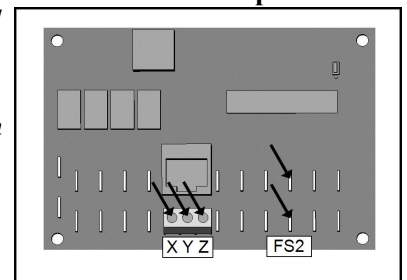

Figure 1

### **Two-wire controller (with internal thermostat):**

1. Deactivate power to chiller.
2. Remove chiller electrical access panel.
3. Route the control wiring to the low voltage side of the electrical enclosure. Follow all National Electric Codes (NEC) unless State or Local guidelines supersede.
4. Connect the controller wires to the microprocessor as follows:
  - Connect one wire to "Y". See Figure 1.
  - Connect other wire to "Z".
  - The polarity of the wire is not important.
5. Reattach chiller access panel.
6. Apply power to chiller.
7. Program chiller for a two-wire controller. See "Using JAO interface" on page 15.
8. Test external controller. See "Operating Chiller (With an External Controller)" on page 24.

### **Three-wire controller (with "OFF" position):**

1. Deactivate power to chiller.
2. Remove chiller electrical access panel.
3. Route the control wiring to the low voltage side of the electrical enclosure. Follow all National Electric Codes (NEC) unless State or Local guidelines supersede.
4. Connect the controller wires to the microprocessor as follows:
  - Connect "High" or "Spa" wire to "X". See Figure 1.
  - Connect "Common" wire to "Y".
  - Connect "Low" or "Pool" wire to "Z".
5. Reattach chiller access panel.
6. Apply power to chiller.
7. Program chiller for a three-wire controller. See "Using JAO interface" on page 15.
8. Test external controller. See "Operating Chiller (With an External Controller)" on page 24.

### **Three-wire controller (without an "OFF" position):**

1. Deactivate power to chiller.
2. Remove chiller electrical access panel.
3. Route the control wiring to the low voltage side of the electrical enclosure. Follow all National Electric Codes (NEC) unless State or Local guidelines supersede.
4. Connect the controller wires to the microprocessor as follows:
  - Connect "Common" wire to one terminal of "FS2". See Figure 1.
  - Connect "Spa" to other terminal of "FS2".
  - The third wire is not used.
5. Reattach chiller access panel.
6. Apply power to chiller.
7. Program chiller for an external controller. See "Using FS2 interface" on page 16.
8. Test external controller. See "Operating Chiller (With an External Controller)" on page 24.



### 3.5 Service Level Programming



**CAUTION** - Failure to heed the following may result in equipment damage.

- Service Level Programming must only be attempted by authorized personnel.
- Unauthorized adjustments in the Service Menu (beyond the **LDC** menu) may void the chiller's warranty.
- Resetting the microprocessor to access a locked keypad will reset all settings to factory default including any installer-entered configuration. Re-programming all custom site condition settings will be required when using this reset. See "Reset to Factory Defaults Settings" on page 17.
- For further assistance, please contact AquaCal® Technical Support. See "Contacting AquaCal AutoPilot, Inc." on page 1.

**PLEASE NOTE -**

Before changing multiple program options, it is recommended that the user lock option be disabled. See "User Lock Option (Disable)" on page 23.

The lockout option can be re-enabled after all changes are completed.

### Service Level Factory Defaults

Certain programming options have been preset at the factory. These options can be overwritten for certain site-specific conditions.

Table 3 - Default Program Parameters Chart

CODE	DESCRIPTION	DEFAULT VALUE	RANGE
<b>CFD</b>	Call-Flex Options	0	Set to off at the factory.
<b>dbP</b>	Pool Dead-Band Differential	1°	Set at factory. Do not adjust.
<b>dbS</b>	Spa Dead-Band Differential	1°	Set at factory. Do not adjust.
<b>dEL</b>	Compressor Time Delay	1 (4 minutes)	Set to on (at 4 minutes) at the factory. Do not adjust.
<b>dSC</b>	Defrost Sensor	Factory Calibrated	Set at factory. Do not adjust.
<b>dFd</b>	Defrost Delay	Factory Calibrated	Set at factory. Do not adjust.

CODE	DESCRIPTION	DEFAULT VALUE	RANGE
<i>FS2</i>	Flow Switch / Automatic Thermostat Switching Option	0	0 = "No Switch" 1 = "Enable Switch"
<i>JAO</i>	External Controller	0	0 = "No Controller" 2 = "Two Wire Controller" 3 = "Three Wire Controller"
<i>LOC</i>	Service Level Entry Point	50	00 - 99
<i>ESC</i>	Water Sensor	Factory Calibrated	Set at factory. Do not adjust.

## Programming for an External Controller

Configure chiller for external control.

### Using *JAO* interface

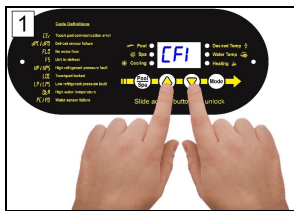

Press "Up" and "Down" buttons simultaneously until *CF 1* appears.

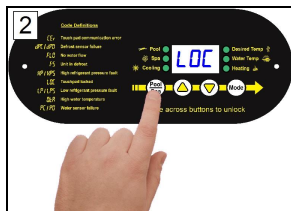

Press "Pool / Spa" button until *LOC* is displayed.

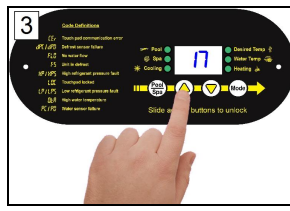

Press "Up" or "Down" to passcode. Default is "17".



Press "Pool / Spa" button once.

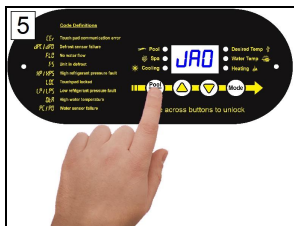

Press the "Pool / Spa" button until *JAO* is displayed.

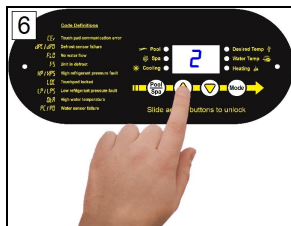

Press "Up" or "Down" button.

- "0" - none
- "2" - two-wire
- "3" - three-wire

## Using F52 interface

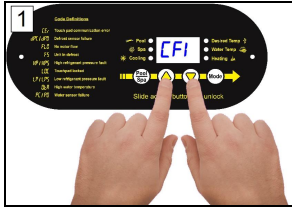

Press "Up" and "Down" buttons simultaneously until **CF 1** appears.

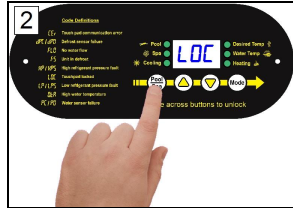

Press "Pool / Spa" button until **LOC** is displayed.

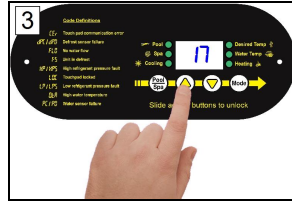

Press "Up" or "Down" to passcode. Default is "17".

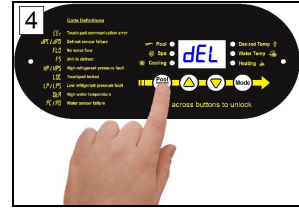

Press "Pool / Spa" button once.



Press the "Pool / Spa" button until **F52** is displayed.

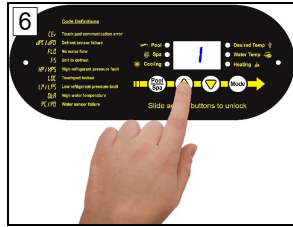

Press "Up" or "Down" button.

- "0" - none
- "1" - External

## Programming for a Relay Switch

Configure chiller for a relay or flow switch. This can provide automatic pool/ spa thermostat switching.

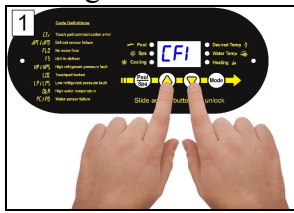

Press "Up" and "Down" buttons simultaneously until **CF 1** appears.

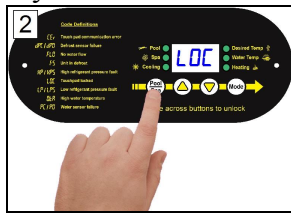

Press "Pool / Spa" button until **LOC** is displayed.

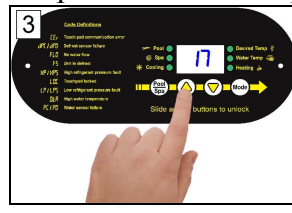

Press "Up" or "Down" to passcode. Default is "17".

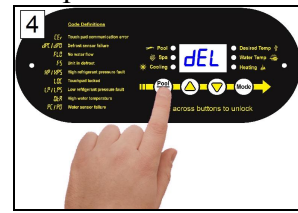

Press "Pool / Spa" button once.



Press the "Pool / Spa" button until **F52** is displayed.

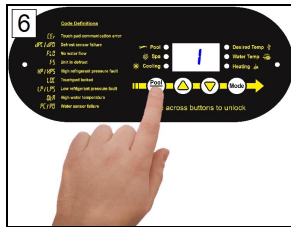

Press the "Up" or "Down"  
• "0" - not active  
• "1" - enable

Once the **F52** feature has been activated the "POOL / SPA" button will no longer function. The relay or flow switch is used to change between the pool and spa temperature settings.

## Reset to Factory Defaults Settings

- ⚠ CAUTION** - Failure to heed the following may result in equipment damage.
- Using this option will reset **ALL** settings to their factory defaults including external controller settings and sensor calibrations. **DO NOT** perform this operation if unsure of site specific settings or how to reset them on the chiller.
  - If a qualified technician is unavailable, please contact AquaCal® Technical Support. See "Contacting AquaCal AutoPilot, Inc." on page 1.

1. Simultaneously Press "Pool / Spa" button and "Up" button until the display shows **888**.
2. Release buttons. Reset is complete.



## SECTION 4 - OPERATION

### 4.1 Energizing Chiller

Turn power on at external fuse box or breaker disconnect.

- Controller performs a lamp test.
- The display reads **888**.
- Controller then displays as normal. See "Display" on page 19.

### 4.2 Display Door

The display panel is located in a door compartment on the front of the chiller. This compartment is designed to protect the display against harsh weather. It can also be padlocked for extra security.

- Press the bottom of the panel to open the display panel door.
- To close, push the display panel up. Then press the bottom of the panel in until a clicking noise is heard.

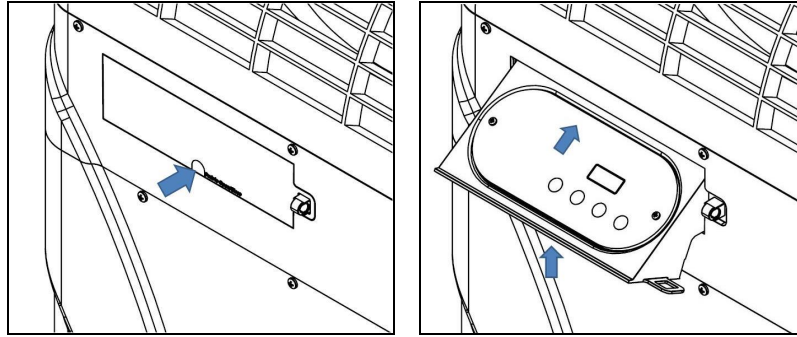

### 4.3 Display Lock

The chiller has a display lock to protect against inadvertent setting changes. To activate display and controls, slide finger across the controls as shown from left to right.

- The code **UnL** will briefly appear, then the set temperature or mode will display.
- This is different than a user-lock which requires a pass code. See "User Lock Option (Enable)" on page 22.

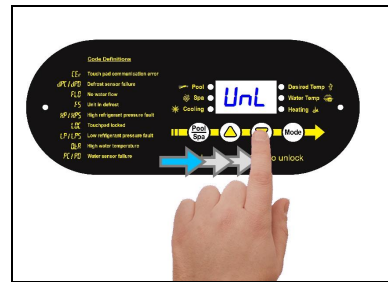

### 4.4 Display Panel

The following information outlines the operation for a standard installation.

#### Display Panel

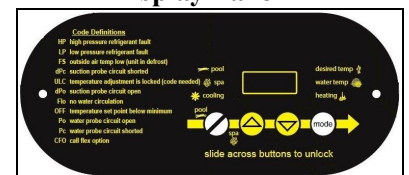

#### 4.4.a Buttons

Buttons	Description
<b>Display Lock</b>	Sliding your finger across the buttons from left to right will temporarily disable the display lock.
<b>Pool / Spa</b>	Select either the pool or the spa thermostat.
<b>Up Arrow</b>	Used to increase temperature set point and navigate through menu options.
<b>Down Arrow</b>	Used to decrease temperature set point and navigate through menu options.
<b>Mode</b>	Select chiller's operating mode.

#### 4.4.b Indicator Lights

<b>Indicators</b>	<b>Description</b>
<b>Pool</b>	The Chiller is referencing the pool thermostat.
<b>Spa</b>	The Chiller is referencing the spa thermostat.
<b>Cooling</b>	Indicates the unit is cooling the water. Please note - the compressor must be operating before this light will illuminate.
<b>Water Temp</b>	Indicates current water temperature.
<b>Desired Temp</b>	Indicates temperature set point is displayed. This is displayed when "UP" or "DOWN" is selected.

#### 4.4.c Display

<b>Display</b>	<b>Description</b>
<b>75</b>	The chiller is on and displaying the current water temperature. In this example 75° F is displayed.
<b>FLO</b>	No water flow is detected. The filter pump is off or chiller is not receiving correct water flow.
<b>OFF</b>	The chiller has been turned off via the mode selector button or the temperature set point has been lowered below 45° F.
<b>BBB</b>	The control program is initializing. This displays only as power is applied to the chiller. The program version number will then be displayed.
<b>CF 1</b>	Select water temperature format (in either Celsius or Fahrenheit).
<b>ULC</b>	Enable chiller lockout feature.
<b>ELC</b>	Select passcode to lock the keyboard.
<b>LDC</b>	This is a Service Entry Point (not intended for use by the owner). The <b>LDC</b> code permits service personnel to enter a factory passcode to access adjustable calibration and site dependent setup parameters. Service adjustments are available to authorized installation and service personnel, only.

## 4.5 User Level Factory Defaults

Certain programming options have been preset at the factory. These options can be overwritten for site-specific conditions.

**⚠ CAUTION** - Failure to heed the following may result in equipment damage.

- Unauthorized adjustments in the Installer Menu (beyond the **LOC** menu) may void chiller's warranty.

Table 4 - Factory Defaults

CODE	DESCRIPTION	DEFAULT VALUE	RANGE
<b>OFF</b>	Chiller is deactivated.		
<b>HEA</b>	This is not an active feature on this equipment.		
<b>COO</b>	Set to cool water to point set on thermostat.		
<b>ACH</b>	This is not an active feature on this equipment.		
<b>CF 1</b>	Celsius / Fahrenheit Selection	1	0 = Celsius 1 = Fahrenheit
<b>ELC</b>	Enter Lock Code	0	0 - 99
<b>ULC</b>	User Lock Code	0	0 = "User Lock Disabled" 1 = "User Lock Enabled"

## 4.6 Setting Operating Mode

**PLEASE NOTE**  
Do not attempt to operate chiller in heat modes **HEA** or **ACH**. This is not an active feature on this equipment.

**Cool Mode**

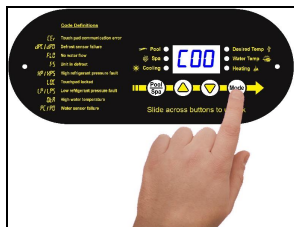

**Deactivate Chiller**



Heating / Cooling modes only available on select equipment. Confirm chiller features before setting a mode.

## 4.7 Selecting Celsius or Fahrenheit

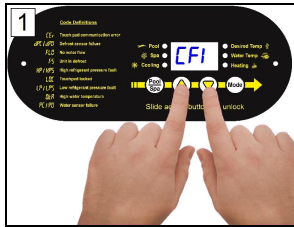

Hold "UP" and "DOWN" until "CF" displays.

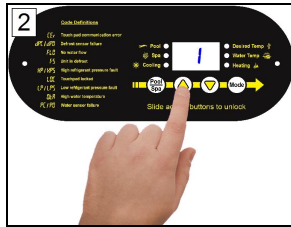

Press "UP" or "DOWN" button to select.  
"0" - Celsius  
"1" - Fahrenheit

## 4.8 Setting Thermostats

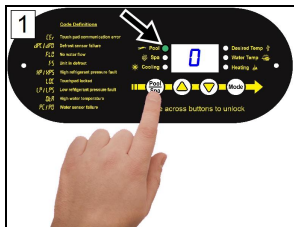

Select "POOL" or "SPA"

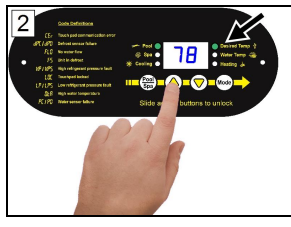

Press "UP" or "DOWN" to the desired temperature.

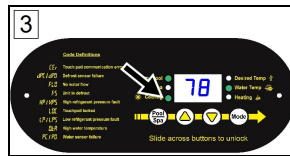

- The cooling indicator will illuminate when cooling the water.



## 4.9 User Lock Option (Enable)

The user-lock feature allows the chiller display panel to be "locked". This can prevent unauthorized temperature adjustments in commercial applications.

- Do not confuse a user-lock with the display lock. See "Display Lock" on page 18.
- If **LOC** is briefly displayed, followed by a "0", the chiller is already locked.
- If the user-lock code has been misplaced, please contact AquaCal® Customer Service for further assistance.

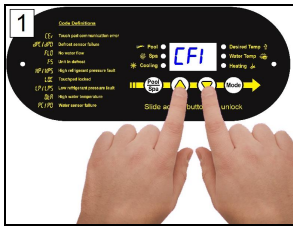

Hold "UP" and "DOWN" until **CFI** displays.



Press "POOL / SPA" button until **ELC** is displayed.



Press "UP or "DOWN" button to change or add a numerical password

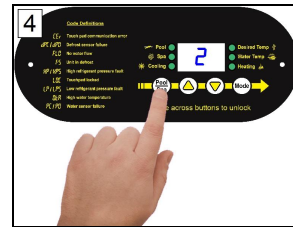

Press "POOL / SPA" button to lock in the password.

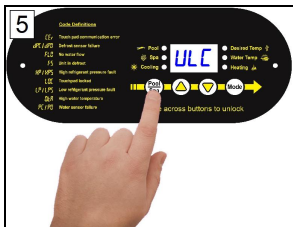

Press "POOL / SPA" button until **ULC** is displayed.

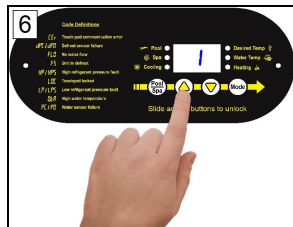

Press "Up" button till "1" is displayed to enable.

## 4.10 User Lock Option (Disable)

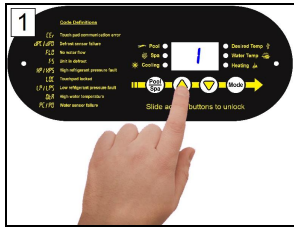

Use "UP" button to enter existing password.

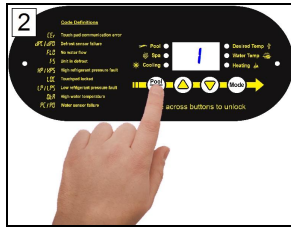

Press "Pool / Spa" button to unlock.

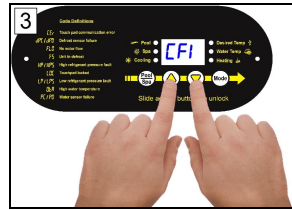

Hold "UP" and "DOWN" buttons until **CFI** is displayed.

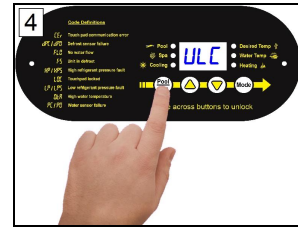

Press "POOL / SPA" button until **ULL** is displayed



Press "DOWN" button until "0" is displayed.

## 4.11 User Lock Option (Entering Pass Code)

If **LDC** is briefly displayed when attempting to change a chiller's settings followed by a "0", the chiller is in a user-lock mode. A numerical passcode is required to proceed.

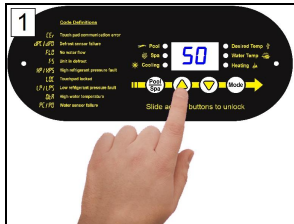

Press "UP" or "DOWN" arrow to enter user lock code.



Press "POOL / SPA" button to unlock.

### **NOTE -**

- After three seconds of inactivity, the chiller's display lock will activate. See "Display Lock" on page 18.
- If the user-lock code has been misplaced, please contact AquaCal® Customer Service for further assistance.

## 4.12 Operating Chiller (With an External Controller)

### Controller with an internal thermostat control

#### Activating Chiller

1. Set the desired temperature at the external controller.
2. Use the external controller to select either the "Pool" or "Spa" to heat.

#### Deactivating Chiller

- Set the external controller to "OFF".

Please note - If equipped, the chiller's cooling function **will be disabled** when using this type of controller.

If the cooling function is needed, the chiller must be temporarily re-programmed for local control.

- Set the chiller to operate with external control temporarily set to "none".
- See "Programming for an External Controller" on page 15.
- It is ok to leave external controller wires in place while the chiller is set for local control.

### Controller with 2 positions - ("Pool" and "Spa" - *no internal thermostat control*)

#### Activating Chiller

1. Set the desired temperatures on the chiller thermostats. See "Setting Thermostats" on page 21.
2. Use the external controller to select either the "Pool" or "Spa" to heat.
  - *Rapid movement between thermostats without a "rest" between each change can cause a missed signal by the chiller.*

#### Deactivating Chiller

- Go to the heat pump and set the mode to "OFF". See "Setting Operating Mode" on page 20.

Please note - If equipped, the chiller's cooling function **will be disabled** when using this type of controller.

If the cooling function is needed, the chiller must be temporarily re-programmed for local control.

- Set the chiller to operate with external control temporarily set to "none".
- See "Programming for an External Controller" on page 15.
- It is ok to leave external controller wires in place while the chiller is set for local control.

### Controller with 3 positions - ("High", "Low", and "Off" - *no internal thermostat control*):

#### Activating Chiller

1. Set the desired temperatures on the chiller thermostats. See "Setting Thermostats" on page 21.
2. Use the external controller to select either "High" or "Low" to heat.
  - *When changing between thermostats, select "Off" first. Then select desired thermostat.*
  - *Rapid movement between thermostats without a "rest" between each change can cause a missed signal by the chiller.*

#### Deactivating Chiller

- Set the external controller to "OFF".

## SECTION 5 - MAINTENANCE

### 5.1 Water Chemistry

Check water chemistry regularly and maintain within recommended levels. Standards for commercial applications vary in different areas. Follow all local applicable codes.

**⚠ CAUTION** - Failure to heed the following may result in equipment damage.

- Do not allow water to flow through chiller when refinishing or acid washing a pool. Either use an installed bypass to route water away from chiller or deactivate filter pump.
- To avoid damage to equipment, monitor and maintain chemistry within recommended levels.

<b>CHEMISTRY LEVEL CHART (RESIDENTIAL)</b>		
<b>CHEMICAL</b>	<b>POOLS</b>	<b>SPAS</b>
<b>Chlorine</b>	1.0 – 3.0 ppm	3.0 – 5.0 ppm
<b>Bromine</b>	2.0 – 6.0 ppm	2.0 – 6.0 ppm
<b>Cyanuric Acid</b>	30 - 50 ppm	30 - 50 ppm
<b>pH</b>	7.4 – 7.6 ppm	7.4 – 7.6 ppm
<b>Total Alkalinity</b>	80 – 120 ppm	80 – 120 ppm
<b>Calcium Hardness</b>	200 – 400 ppm	150 – 250 ppm
<b>Total Dissolved Solids*</b>	0 – 1,500 ppm	1,500 ppm above start-up total dissolved solids in spas

\* Salt from a chlorine generator is not included in Total Dissolved Solids.

### 5.2 Cleaning Equipment After Installation

Installer - If you need to clean equipment after installation, please use the following guidelines.

**⚠ WARNING** - Failure to heed the following may result in injury or death.

- Possible electric shock hazard - Deactivate power to all electrical devices on the pad when washing chiller. Do not restore electrical power until equipment is completely dry.

**⚠ CAUTION** - Failure to heed the following may result in equipment damage.

- Do not use a pressure cleaner to wash chiller. Damage to chiller components may result. If using a hose-end spray nozzle adjust spray pattern to low strength only.
- Do not spray water directly into the interior of the chiller; damage to components may result.
- Do not use chemicals on the display panel.

## Cleaning

1. Wash outside cabinet using a low-pressure water hose. A high-pressure water stream will cause damage to the aluminum fins of the chiller. This damage is not covered under product warranty.
2. While the chiller is still wet, use an approved cleaning agent to clean the exterior of the chiller. **Do not use chemicals on the display panel.**
3. Use a detergent-dampened cloth to wipe the chiller's exterior cabinet.
4. Flush all exterior with fresh water using a low-pressure water hose.
5. Dry the exterior cabinet using a soft cloth being careful not to damage condenser fins.

<b>APPROVED CLEANING AGENTS*</b>
Fantastic®
Formula 409®
Cascade®
All Power Plain Detergent (3% Solution)

Table 5 - Cleaning Agents

## Polishing

1. Polish the chiller's cabinet panels using an approved polishing agent and following the manufacturer's instructions. Do not use chemicals on the display panel.
2. Rinse the chiller panels with fresh water, wipe, and buff panels using a dry soft cloth.
3. Allow chiller interior and surrounding equipment to "air-dry" for several hours prior to restoring electrical power.

<b>APPROVED POLISHING AGENTS*</b>
Simoniz® Wax
Glo-Coat®
Armor All® Protectant

Table 6 - Polishing Agents

- \* The trademarks used in approved cleaning and polishing agents are property of their owners and are not related to AquaCal®.

## 5.3 Planned Maintenance

An annual inspection and maintenance program is strongly recommended starting no longer than one year after installation of the chiller. In coastal areas a bi-annual inspection is recommended. See recommended inspection checklist.

AquaCal® can perform this service in limited areas. Contact Customer Support for more information.

**⚠ WARNING** - Failure to heed the following may result in injury or death.

- Annual inspection and service must be performed by a qualified chiller specialist in order to prevent physical injury or damage to equipment.

### **RECOMMENDED INSPECTION CHECKLIST:**

- Check Air Temperature Change through Evaporator
- Check and Clean Condensate Drains
- Check Capacitor Value
- Check Compressor Amperage Draw
- Check Electrical Connections
- Check Flow / Pressure Switch
- Check Operating Controls and Temperature Sensors
- Check Water Chemistry
- Check Proper Voltage to Unit
- Check Refrigerant Levels
- Check Relay Contacts
- Check Water Flow
- Check filter pump Amperage Draw
- Check Water Temperature Change through Heat Exchanger
- Clean Condenser's Coil
- Clean Chiller's Cabinet

## **5.4 Winterizing**

**⚠ WARNING** - Failure to heed the following may result in injury or death.

- Deactivate all electrical power to chiller before performing hard freeze procedures.

**⚠ CAUTION** - Failure to heed the following may result in equipment damage.

- Failure to winterize chiller may result in serious equipment damage. Freeze damage is not covered under the chiller warranty.
- While the plumbing connections are in the winterized condition (not fully tightened), it is imperative the pool and spa water not be circulated through the chiller. Loss of water through loose plumbing connections may result in damage to circulation pump, pool and spa structures, and other equipment.

### **Light Freeze Conditions**

There are two freeze conditions requiring chiller attention. A light freeze is when the ambient air temperature falls below 32 degrees Fahrenheit for less than 8 hours. Typically during light freeze conditions circulating (moving) water will not freeze. Override time clocks and allow filtration system to run continuously during light freeze conditions.

### **Hard Freeze Conditions**

A hard freeze is when the ambient air temperature falls below 32 degrees Fahrenheit for more than 8 hours. In areas where this condition is prevalent and sustained, the chiller **MUST** be winterized for hard freeze conditions. Follow the correct procedure depending on the type of heat exchanger found in the chiller.

## **Identify Exchanger:**

1. Deactivate all electrical power to chiller.
2. Deactivate filter pump.
3. Remove front access panel.
4. Identify chiller exchanger from illustrations in this section. Then follow procedure for that chiller's exchanger.

## Titanium ThermoLink® Exchanger (with no Drain)

1. Reinstall front access panel.
2. Disconnect the plumbing to the chiller at connection unions (removal is counter-clockwise).
3. Allow water to drain completely from the chiller. Expect to see a lot of water drain out at first, and then a small amount to continue to drain out over a long period.
4. After chiller is fully drained, reinstall front access panel.
5. Partially reconnect plumbing connection unions.
6. Winterizing is complete.
7. When ready to use chiller again, hand-tighten connection unions. Reconnect electrical power, and set the operating mode on the chiller. Activate filter pump.

No Drain



## Titanium Tube-in-Tube Exchanger

1. Disconnect the plumbing to the chiller at connection unions (removal is counter-clockwise).
2. Allow water to drain completely from the chiller. Expect to see a lot of water drain out at first, and then a small amount to continue to drain out over a long period.
3. Place an air hose into the pool inlet of the chiller; wrap a clean rag around the hose to form a temporary seal.
4. Push all water from the water circuit using compressed air no stronger than 50 psig. The residual water should be forced out of the pool outlet. Allow compressed air to blow into the chiller inlet for at least 15-20 seconds after the water stops coming out.
5. Repeat process on the outlet side of the chiller.
6. Partially reconnect plumbing connection unions.
7. Winterizing is complete.
8. When ready to use chiller again, hand-tighten connection unions. Reconnect electrical power, and set the operating mode on the chiller. Activate filter pump.

Titanium  
Tube-in-  
Tube

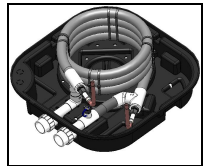

## SECTION 6 - TROUBLESHOOTING

### 6.1 Fault Codes

A fault code indicates a specific issue or condition that will require action before the equipment can resume operating.

Please perform the following troubleshooting.

If the issue reoccurs, please contact AquaCal® Technical Support. See "Contacting AquaCal AutoPilot, Inc." on page 1.

- ⚠ WARNING** - Failure to heed the following may result in injury or death.
- Repairs must not be attempted by untrained or unqualified individuals.
  - The chiller contains refrigerant under high pressure. Repairs to the refrigerant circuit must not be attempted by untrained or unqualified individuals. Service must be performed only by qualified HVAC technicians. Recover refrigerant before opening the system.
- ⚠ CAUTION** - Failure to heed the following may result in equipment damage.
- Service by unauthorized personnel will void the chiller warranty.

## **FLO Indicator**

### **ISSUE**

Low or no water detected.

### **RESOLUTION**

1. Confirm the filter pump is on.
2. If a multiple-speed filter pump is being used, run at a higher speed to determine if the error persists. Do not exceed maximum flow rate for your model.
3. Confirm water is not being diverted away from the chiller.
  - See "Water Flow Rates" on page 4.
  - See "Adjusting Water Flow Using  $\Delta T$  (Delta-T)" on page 5.

## **CEr Indicator**

### **ISSUE**

This can indicate a loose or damaged communication cable.

### **RESOLUTION**

A qualified technician should check the cable from control board to display assembly for a loose connection or visible damage.

## **CSE Indicator**

### **ISSUE**

This is a control system error.

### **RESOLUTION**

Deactivate then reactivate power to reset controls.

## **dPC or dPD Indicator**

### **ISSUE**

Shorted or open defrost sensor.

### **RESOLUTION**

A qualified technician should replace the defrost sensor.

## **PC or PD Indicator**

### **ISSUE**

Shorted or open water sensor.

### **RESOLUTION**

A qualified technician should replace the water sensor.

## **HP Indicator**

### **ISSUE**

The refrigerant system's high-pressure switch is showing as open.

### **RESOLUTION**

Determine if an insufficient amount of air is being supplied to the equipment.

1. Check for proper fan operation. If fan is not operating, contact AquaCal® Technical Support.
2. Check for obstructed air flow around the chiller. See "Clearances" on page 3.
3. Check for dirty or blocked evaporator coil. See "Cleaning Equipment After Installation" on page 25.



## HP5 Indicator

### ISSUE

The chiller has locked due to five **HP** (high-pressure) faults during one call for cooling.

### RESOLUTION

1. Deactivate then reactivate power to the chiller to clear error.
2. Troubleshoot the high-pressure issue causing the error. See "HP Indicator" on page 29.

## LP Indicator

### ISSUE

The refrigerant system's low-pressure switch is showing as open.

### RESOLUTION

Determine if an insufficient amount of water is being supplied to the equipment.

1. Confirm the filter pump is on.
2. If a multiple-speed filter pump is being used, run filter pump at a higher speed. Do not exceed maximum flow rate for the model.
3. Confirm water is not being diverted away from the chiller.
  - See "Water Flow Rates" on page 4.
  - See "Adjusting Water Flow Using  $\Delta T$  (Delta-T)" on page 5.
4. The water pressure switch may be incorrectly calibrated. See "Adjusting Water Pressure Switch" on page 8.

## LP5 Indicator

### ISSUE

The chiller has locked due to five **LP** (low-pressure) faults during one call for cooling.

### RESOLUTION

1. Deactivate then reactivate power to the chiller to clear error.
2. Troubleshoot the low-pressure issue causing the error. See "LP Indicator" on page 30.

## OTR Indicator

### ISSUE

Incoming water temperature exceeded 110° F and the unit is locked with an **OTR** over temperature alarm. The chiller will not operate until incoming water temperature drops to 100° F or lower.

### RESOLUTION

1. Rule out an incorrect reading from the water temperature sensor. Verify existing water temperature with an accurate thermometer. If chiller's sensor is inaccurate, the water temperature sensor may require replacement.

## 6.2 Issues and Resolutions

**⚠ WARNING** - Failure to heed the following may result in injury or death.

- Repairs must not be attempted by untrained or unqualified individuals.
- The chiller contains refrigerant under pressure. Repairs to the refrigerant circuit must not be attempted by untrained or unqualified individuals. Service must be performed only by qualified HVAC technicians. Recover refrigerant before opening the system.

**⚠ CAUTION** - Failure to heed the following may result in equipment damage.

- Service by unauthorized personnel will void the factory warranty.

Please perform the following troubleshooting.

For further assistance, please contact AquaCal® Technical Support. See "Contacting AquaCal AutoPilot, Inc." on page 1.

## Display Panel Not Responding

1. If the chiller is controlled by an external controller, confirm the external controller settings. See "Operating Chiller (With an External Controller)" on page 24.
2. If the issue is still occurring, disconnect external controller from the chiller. Then check operation at chiller.
  - If display panel responds, the problem lies with the external controller or its installation. Contact the manufacturer of the external control device.

## Chillers Not Running

1. Confirm equipment is receiving power. Is the chiller display illuminated?
  - If not, confirm the main breaker (located at the power supply panel) and the disconnect switch (located near the chiller) are both turned on.
  - If the display still does not illuminate, it is recommended that the chiller installer or electrician confirms chiller is receiving power.
2. Confirm correct mode is selected. See "Setting Operating Mode" on page 20.
3. Confirm thermostat is set correctly. See "Setting Thermostats" on page 21.
  - If cooling the water, the thermostat should be set below the current water temperature.
4. If an error code is displayed, diagnose and correct the cause of the code. See "Fault Codes" on page 28.

## Chillers Tripping Breaker

1. Have an electrician confirm breakers are in good condition and properly sized for the chiller.
2. Multiple chillers installed at the same site may benefit from special automatic sequencing controllers to avoid excessive power drops at start-up. See "Automatic Sequencing Controller" on page 34.
3. If a fault occurs immediately when the compressor starts, a qualified technician should evaluate the system.

## Chiller Won't Shut Off

### **PLEASE NOTE**

*When chiller is set to "OFF", the display will show either the water temperature or **FLD**.*

1. Confirm the chiller has reached the desired temperature set on the thermostat. The chiller will continue to run until the set temperature is reached.
2. If the chiller is incorrectly set to **HEA** or **ACH** mode, the unit will not deactivate.
  - See "Setting Operating Mode" on page 20.
3. If the chiller is using an external controller, it may not be set correctly.
  - See "Operating Chiller (With an External Controller)" on page 24.

## Chiller Is Running, Not Cooling (Reversing Models)

1. If the chiller is using an external controller, confirm the chiller is programmed properly to allow for cooling. See "Operating Chiller (With an External Controller)" on page 24.
2. Confirm the chiller mode is set to **CDD** operating mode.
3. Confirm the thermostat is set below the current water temperature.
4. Confirm valves are correctly positioned to cool the correct body of water (either the pool or the spa). If cooling a spa that overflows into a pool, confirm the spa is isolated when being cooled (not flowing into the pool).
5. If an error code is displayed, determine and correct the condition causing the code. See "Fault Codes" on page 28.
6. Confirm chiller is transferring heat out of the water.
  - Measure the temperature of air discharge coming out of chiller fan. If discharge air is between 8° to 10° warmer than outside ambient air (not coming out of chiller), then the chiller is moving heat out of the water.
7. Confirm that filter pump has a sufficient run-time. The chiller will not run (or cool the water) without water flow. Chiller equipment will generally be set to run 24 hours a day in commercial applications. See "Initial Cooling Recommendations" on page 34.

## **Water Coming From Chiller**

The water may be normal condensation produced as a by-product of the chiller's refrigeration process.

Determine if the water is condensation or a possible leak.

1. If using chlorine or bromine as a pool / spa sanitizer, use a test strip in the water at chiller to determine if sanitizer is present. If sanitizer is present, a leak may exist.
2. Deactivate chiller, leaving the filter pump on. After several hours, determine if water is still coming from the chiller.

# SECTION 7 - APPENDIX

## 7.1 Identifying Model Specifications

1. Find Data Plate - The data plate is usually posted on the side of the equipment or the inside of the chiller's access plate.
2. Find the model number on the data plate. The first letters and numbers indicate the model type.
3. The complete model number identifies the equipment's specifications.

### Data Plate Example

MINIMUM CIRCUIT AMPACITY	<input type="text"/>	MADE IN THE USA
ELEC. SERVICE: VOLTS	<input type="text"/>	PH <input type="text"/> HZ <input type="text"/>
MAXIMUM TIME DELAY FUSE OR HACR BREAKER	<input type="text"/> 5	
COMPRESSOR VOLTS	R.L.A. <input type="text"/>	L.R.A. <input type="text"/>
FAN MOTOR VOLTS	H.P. <input type="text"/>	F.L.A. <input type="text"/>
REFRIGERANT: Circuit - Factory charged	<input type="text"/>	Only oz/Kg <input type="text"/>
Tested to	<input type="text"/> psig High side /	<input type="text"/> psig Low side
OUTDOOR USE		
AQUA CAL, INC A TEAM HORNER COMPANY 2737 24 <sup>TH</sup> STREET NORTH ST. PETERSBURG, FL 33713 FACTORY SERVICE 727-523-5642	MODEL NUMBER <input type="text"/>	<b>IIIBAR CODEIII</b>
	SERIAL NUMBER <input type="text"/>	<b>IIIBAR CODEIII</b>

### Model Number Example

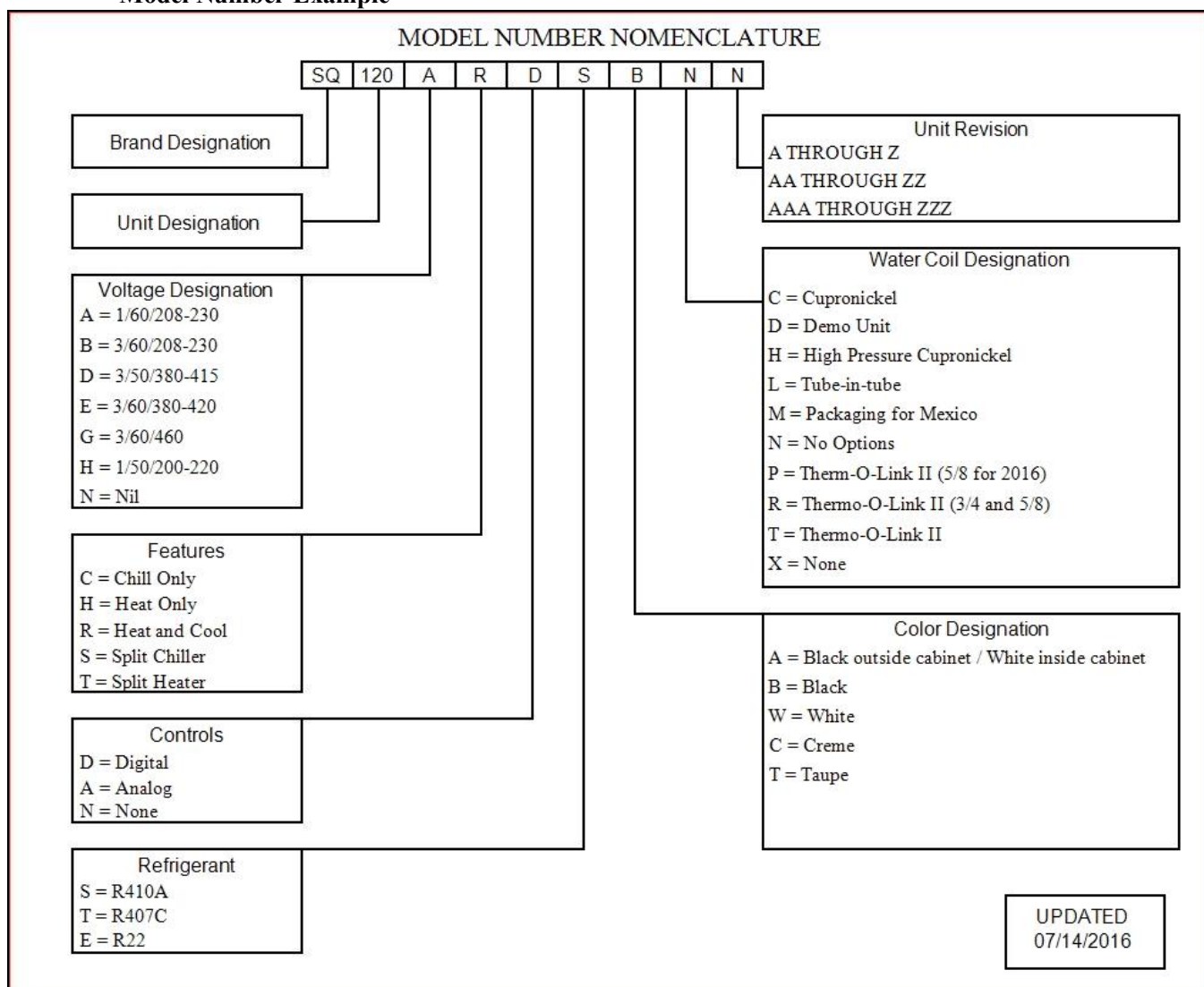

## 7.2 Weights

**NOTE:**

*Specifications subject to change.*

Model Type	Model Number	Install Weight
TropiCool®	TC500	215 Pounds
TropiCool®	TC1000	285 Pounds

Table 7 - Equipment Weight

## 7.3 Initial Cooling Recommendations

The following recommendations will reduce the amount of time required to cool a pool or cold plunge application. **If unsure of equipment cooling capability, review equipment data plate.** See "Identifying Model Specifications" on page 33.

1. Confirm chiller mode has been set to **C00**.
2. Set thermostat to desired water temperature.
3. Temporarily override the filter pump's time-clock for continuous operation.
  - This will allow the Chiller the time required to cool the water at start-up.
  - After the water has reached the desired temperature, the time-clock can be reset to normal operating time-frames.

## 7.4 Available Accessories

### 5 lb Bypass Valve Kit (Kit STK0135)

- When high flow rates are outside recommended tolerances, please use this kit or an alternative bypass valve system.
- This kit can be used to control excessive water flow through the chiller. It provides automatic flow adjustments for most applications.

### Automatic Sequencing Controller

- An Automatic Sequencing Controller (ASC) provides easy control of all units from one lead unit and prevents the simultaneous start-up of multiple chillers.
- Site voltage drop is minimized and utilities are not subjected to large in-rush demands of electrical current.
- Part number is based on number of chiller's to be controlled. Call AquaCal® Customer Support for assistance with correct configuration.

### External Flow Relay (Grid Flow) Switch Kit (0040s)

- Used when the pool / spa elevation is higher than the chiller.
- Used when a variable two-speed filter pump set on low-speed mode does not provide enough water pressure to activate a chiller's water pressure switch.
- Also used for automatic pool / spa thermostat switching.

**PLEASE NOTE -**

*The 0040s is not to be used on applications exceeding 50 PSI.*

### Plumbing Unions:

SIZE	PART NUMBER
2 INCH	2627

### Remote Control Kit (STK0070)

- A remote (wired) control kit allows for full control of the chiller from up to 100 feet from the equipment.