

This legacy manual applied to analog reversing units in production as of 1/30/04.

HEATWAVE

and

AerotempTM

H E A T P U M P S



Pool and Spa Heat Pump Owner's Manual and Installation Guide

PN: LTP0010
01/30/04



Models:
H/AT100R
H/AT120R

Also Applies to:
XL100R
XL120R



ATTENTION INSTALLER:

THIS DOCUMENT IS PURCHASER'S PROPERTY AND IS TO REMAIN WITH THE HEAT PUMP OWNER

TABLE OF CONTENTS

WELCOME TO THE TEAM -----	5
IMPORTANT FEATURES OF YOUR NEW HEAT PUMP -----	6
SAFTEY INFORMATION -----	7
QUICK START & STOP -----	9
PHYSICAL CHARACTERISTICS & SPECIFICATIONS -----	10
Dimensional Information -----	10
Specifications -----	11
Data Plate Nomenclature -----	11
INSTALLATION -----	12
Placement of Heater -----	12
Plumbing Requirements -----	13
Electrical Requirements -----	16
<i>Connecting External Controllers</i> -----	16
START-UP & OPERATION -----	17
Control Panel Features -----	17
Overview of Controls -----	18
Initial Start-up and Basic Operation -----	18
Heating Tips -----	20
Calculating Initial Heating Time -----	21

TABLE OF CONTENTS, *continued*

MAINTENANCE-----	22
Planned Maintenance Program-----	22
General Maintenance -----	23
Maintaining Proper Water Flow -----	24
Maintaining Proper Clearances -----	24
SEASONAL USE & SHUT DOWN -----	24
During the Swim Season -----	24
Freeze protection / Extended Shut Downs-----	24
Winterizing (Hard Freeze Conditions) -----	25
TROUBLESHOOTING-----	28
Common Troubleshooting Issues -----	28
Troubleshooting Flow Charts-----	29
Adjusting Water Flow (Pressure) Switch -----	33
Defrost System: Description & Troubleshooting -----	35
Troubleshooting Problems in the Refrigerant Circuit -----	37
Refrigerant Circuit Performance (T-P) Charts -----	38
REPLACEMENT PARTS -----	41
CONTACTING THE FACTORY -----	42

Welcome to the Team



Dear Owner:

Congratulations on your wise decision to make an AquaCal heat pump part of your home. Since 1981, AquaCal has maintained the worldwide lead in the manufacture of swimming pool & spa heat pumps. Your new heat pump is not only a great investment, but also the most cost effective method available for heating pools and spas. For example, your heat pump is up to 400% more efficient than gas, and, when compared to electric resistance heat, your heat pump is nearly 600% more effective. You can rest assured that your new heat pump is of the highest quality and efficiency, and is designed and built to provide years of trouble-free operation.

Moreover, should you decide you would like AquaCal to provide regular inspection and maintenance of your heat pump—*which we do recommend*—you will find that AquaCal’s factory-trained service staff is the largest and most-qualified in the pool & spa heat pump industry.

“You can rest assured that your new heat pump is of the highest quality and efficiency, and is designed and built to provide years of trouble-free operation.”

Important Features of Your New Icebreaker Heat Pump

ThermoLink Heat Exchanger

The heart of your heat pump is the patented ThermoLink heat exchanger. The primary cause of premature heat pump demise is the failure of the heat exchanger. Ordinary heat exchangers are made from a cupronickel alloy. This cupronickel material is susceptible to attack from the sanitizers used in pools and spas, and from other related water chemistry conditions. Once the heat exchanger fails, the heat pump is ruined. The ThermoLink heat exchanger tube is made from titanium, and is virtually impervious to water chemistry damage.

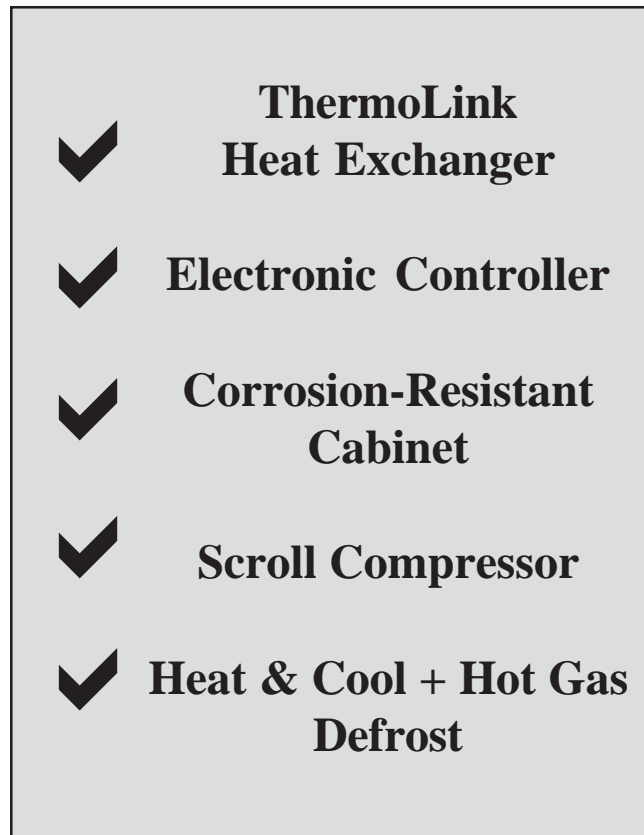

Electronic Controller

State-of-the-art, solid-state electronic controller, maintains water temperature within 1°F of set point. Controller also permits user to predefine different Pool and Spa water temperature set points.

Corrosion-Proof Cabinet

The cabinet, being made from resilient, UV-Protected ABS material, can never rust, fade, or corrode. You can expect the cabinet to retain a like-new appearance with only an occasional wash down and—if so desired—a quick waxing.

Scroll Compressor

50% fewer moving parts than standard piston-type compressors. This equates to much improved reliability and improved efficiency. Scroll compressors are also much quieter in operation than piston-type compressors.

Heat & Cool Capability

Puts you in full control, year round ...Warms your pool or spa with the reliability and efficiency of our other heat pumps, but, with the flip of a switch, can also cool your pool or spa to refreshing temperatures during the hot summer months. For cooler climates, *Icebreaker* heat pumps offer unique advantages over passive defrost models. Please read more below...

Hot Gas, Icebreaker Defrost

Your *Icebreaker* heat pump is uniquely equipped for active defrost. Active defrost involves directing hot refrigerant gas to the heat collector, melting accumulated ice away in a matter of a few minutes—then right back to heating. Standard heat pumps may remain “off in defrost” for extended periods during very cold weather. Because of its ability to continue to operate even during freezing weather, your *Icebreaker* extends the swimming season longer than any other heat pump.

PLEASE SPEND A FEW MINUTES READING FURTHER TO BECOME FAMILIAR WITH ALL THE FEATURES, THE SAFE OPERATION, AND THE CARE OF YOUR NEW HEAT PUMP.

SAFETY INFORMATION

Used and maintained properly, your heat pump will provide year-upon-year of safe and economical service. However, as with any mechanical or electrical device, to get the most from your heat pump—while insuring personal safety for you and others—certain operational and maintenance factors must be observed.

Likewise, excepting a few minor owner-capable maintenance items (explained later in this manual), repair and service of your heat pump must be performed only by experienced service personnel. Should you, the owner, suspect your heat pump is not performing properly, by referring to the section in this manual entitled: "Troubleshooting", you will be able to determine if a call for service is required. Your installer can be one source of service, or AquaCal Customer Support personnel stand ready to assist you at: (800) 786-7751. For questions concerning installation, modifications, operation, service and upkeep, please contact your installer or AquaCal Customer Support. Warranties may be voided if the heater has been used, maintained, or repaired improperly.

In addition to possible voiding of warranties: unapproved installation methods, nonstandard modifications, poor or incorrect maintenance, service by unqualified personnel, or improper use of this unit, may result in personal injury and/or property damage. For personal safety and to avoid damage to equipment, it is important that safety instructions displayed on the heat pump, and within this manual, are read, understood, and followed.

Throughout this manual the following two safety signals are placed where particular care is required. Please note "WARNING" relates to personal safety, while "CAUTION" signals promote avoiding damage to equipment.

WARNING !

Failure to heed the following may result in permanent injury or death.

This "Warning" symbol appears in this manual where special attention is required for personal safety.
Specific instructions will appear in this box.

CAUTION !

Failure to heed the following may result in damage to equipment.

This "Caution" symbol appears in this manual where special care is required to avoid equipment damage.
Specific instructions will appear in this box.

Water Temperature Safety

WARNING !

Failure to heed the following may result in permanent injury or death.

Prolonged immersion in water warmer than normal body temperature may cause a condition known as HYPERTHERMIA. The symptoms of hyperthermia include: unawareness of impending hazard, failure to perceive heat, failure to recognize the need to exit the spa, and unconsciousness. The use of alcohol, drugs, or medication can greatly increase the risk of fatal hyperthermia. In addition, persons having an adverse medical history, or pregnant women, should consult a physician before using a hot tub or spa. Children and the extreme elderly should be supervised by a responsible adult.

Heater NOT Repairable by Owner

WARNING !

Failure to heed the following may result in permanent injury or death.

Heat pumps contain no owner-repairable components. Repairs must not be attempted by untrained and/or unqualified individuals. If service is deemed necessary, contact installing dealer or AquaCal Customer Support at (800) 786-7751.

Refrigerant Circuit Service Only by Qualified, EPA Certified Technician

WARNING !

Failure to heed the following may result in permanent injury or death.

Heater contains refrigerant under high pressure. Repairs to the refrigerant circuit must not be attempted by untrained and/or unqualified individuals. Service must be performed only by qualified HVAC technicians. Recover refrigerant to relieve pressure before opening system.

Water Chemistry Safety

WARNING !

Failure to heed the following may result in permanent injury or death.

Improper water chemistry can present a serious health hazard. To avoid possible hazards, maintain Pool/Spa water per standards below.

CAUTION !

Failure to heed the following can result in damage to equipment.

While your heat pump's titanium-based heat exchanger provides nearly impervious protection against poor water chemistry, improper water chemistry may cause expensive damage to pump, filter, pool shell, etc. To avoid equipment damage, maintain Pool/Spa water per standards below.

RECOMMENDED WATER CHEMISTRY STANDARDS

Chlorine	1.0 – 3.0 ppm in pools, 1.5 – 3.0 ppm in spas
Bromine	2.0 – 4.0 ppm in pools, 3.0 – 5.0 ppm in spas
pH	7.4 – 7.6 ppm in pools, 7.2 – 7.8 ppm in spas
Total Alkalinity	80 – 140 ppm in pools, 80 – 120 ppm in spas
Calcium Hardness	200 – 400 ppm in pools and spas
Total Dissolved Solids	1,000 – 2,000 ppm in pools, 1,500 ppm above start-up TDS in spas

HEATING-QUICK START & STOP

This brief information is provided as an aide to installers, service personnel, and owners. The intent of this section is to provide rapid access to (only) very basic operational information. Individuals who will be routinely using, installing, maintaining, and servicing this heat pump, are strongly encouraged to read this entire manual. If uncertain about any instructions given herein, AquaCal Customer Support (800-786-7751) should be contacted for additional information. Note: The terms “Heat Pump” and “Heater” are used synonymously.

Start Up

1. With water pump OFF, position water valves to heat the POOL or SPA.
2. Set water pump controls to allow for temporary, continuous operation.
3. Rotate both thermostats counterclockwise to lowest temperature settings.
4. Depending on valve settings (per #1, above), position the POOL/OFF/SPA toggle switch to point at either the POOL or SPA thermostat knob. Set HEAT/COOL toggle switch to HEAT position.
5. Ensure power is supplied to the heater, then start the water pump; the POWER and FLOW lights should now both be lit. Permit the water pump to operate for five (5) minutes before proceeding.

Setting the Temperature Controls - Pool or Spa

1. Turn the selected pool or spa thermostat dial clockwise to its highest setting.
2. The heat pump will start and begin to warm the pool or spa.
NOTE: The heat pump utilizes a short-cycle time delay device. If heat pump does not start, wait five (5) minutes; the time delay may be preventing the heat pump from starting.
3. Initially, the typical spa may take several hours to heat, while a pool may take several days. Heating time will depend on the volume of water, beginning water temperature, and the weather conditions at the time of start-up. (*Also see Table of Contents item: Calculating Initial Heating Time.*)
4. When the pool or spa reaches the desired temperature, *slowly* rotate the thermostat knob counterclockwise until the heat pump (just) stops. The thermostat is now positioned to automatically maintain the set temperature.

Time Clock Programming

Once the heat pump has brought the pool or spa up to temperature, it will be necessary to reset the pump run-time controls. Be sure to allow enough running time for the heat pump to replace lost heat. Required run time will vary depending upon the time of year. Colder months require longer running times—generally eight to twelve hours/day.

Switching Controls from Pool to Spa

NOTE: It is best to stop the water pump while repositioning valves.

1. Open spa valves and close pool valves.
2. With the spa water circulation pump operating for at least five minutes, move the POOL/OFF/SPA toggle switch from the POOL setting to the SPA setting.
3. Turn the Spa thermostat fully clockwise (104° F). Heat pump should start (also see time delay note, above).
4. Initially, the typical spa may take several hours to heat. Heating time will depend on the volume of water, beginning water temperature, and the weather conditions at the time of start-up.
5. When the spa reaches the desired temperature (104° F is maximum), *slowly* rotate the SPA thermostat knob counterclockwise until the heat pump (just) stops. The spa thermostat is now positioned to automatically maintain the set temperature.

To Stop the Heat Pump

The heat pump can be stopped by interrupting the electrical power supply, or by setting the desired temperature lower than the actual water temperature. However, please note, if electrical power and water flow are present to the heat pump, and the water temperature falls below 60°F (with thermostat set to minimum), the heat pump will operate to maintain the water temperature at 60°F.

PHYSICAL CHARACTERISTICS

&

SPECIFICATIONS

Dimensional Information - Heat Wave/AeroTemp 100-120 Series (All Reversing Models)

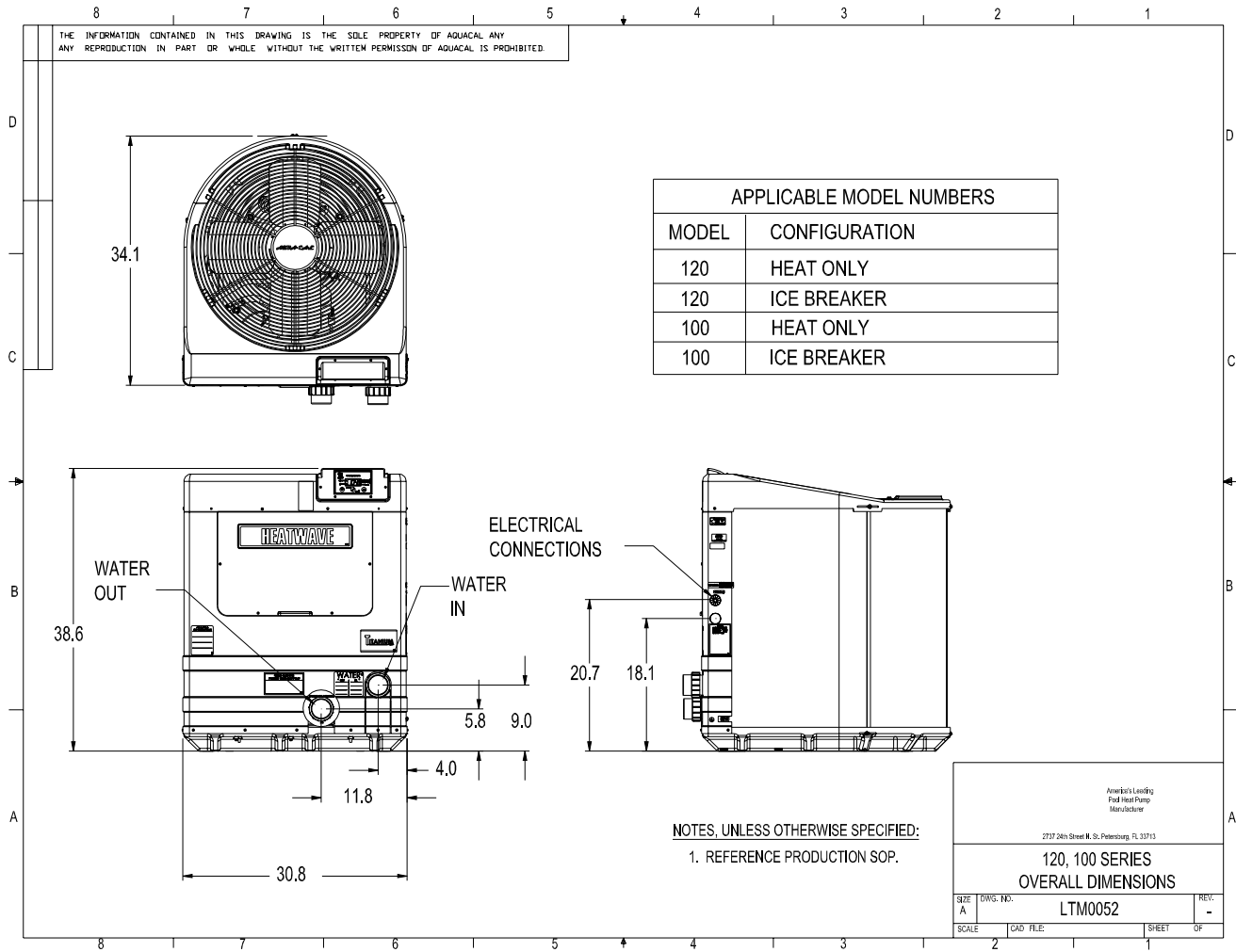

Specifications — H/AT100R & 120R Models

100-SERIES:	H100AR AT100AR	H100BR AT100BR	H100DR AT100DR	H100HR AT100HR
BTU - 80%RH				
Air °F / Air °F... 80/50	88,000/63,000			
COP	5.6/4.1			
BTU - 63% RH				
Air °F / Air °F... 80/50	83,000/57,000			
COP	5.3/3.9			
Kilowatt Input (80% RH)	4.6			
Voltage/Hz/Phase	208-230/60/1	208-230/60/3	380-415/50/3	220-240/50/1
Min. Circuit Ampacity	38.16	22.13	11.62	26.14
Rec. Fuse or Breaker Size	40	30	15	30
Max. Fuse or Breaker Size	60	35	20	40
Min-Max Water Flow (gpm)	20-70	20-70	20-70	20-70
Shipping weight (lbs)	320	320	320	320
Shipping Size (LXWXH)	36" X 40" X 43"	36" X 40" X 43"	36" X 40" X 43"	36" X 40" X 43"
Uncrated Weight	293	293	293	293
120-SERIES:	H120AR AT120AR	H120BR AT120BR	H120DR AT120DR	H120HR AT120HR
BTU - 80%RH				
Air °F / Air °F... 80/50	103,000/70,000			
COP	5.4/4.1			
BTU - 63% RH				
Air °F / Air °F... 80/50	99,000/68,000			
COP	5/3.8			
Kilowatt Input (80% RH)	5.6			
Voltage/Hz/Phase	208-230/60/1	208-230/60/3	380-415/50/3	220-240/50/1
Min. Circuit Ampacity	38.16	26.14	12.82	36.56
Rec. Fuse or Breaker Size	40	30	15	40
Max. Fuse or Breaker Size	60	40	20	60
Min-Max Water Flow (gpm)	20-70	20-70	20-70	20-70
Shipping weight (lbs)	330	330	330	330
Shipping Size (LXWXH)	36" X 40" X 43"	36" X 40" X 43"	36" X 40" X 43"	36" X 40" X 43"
Uncrated Weight	303	303	303	303

Data Plate Nomenclature

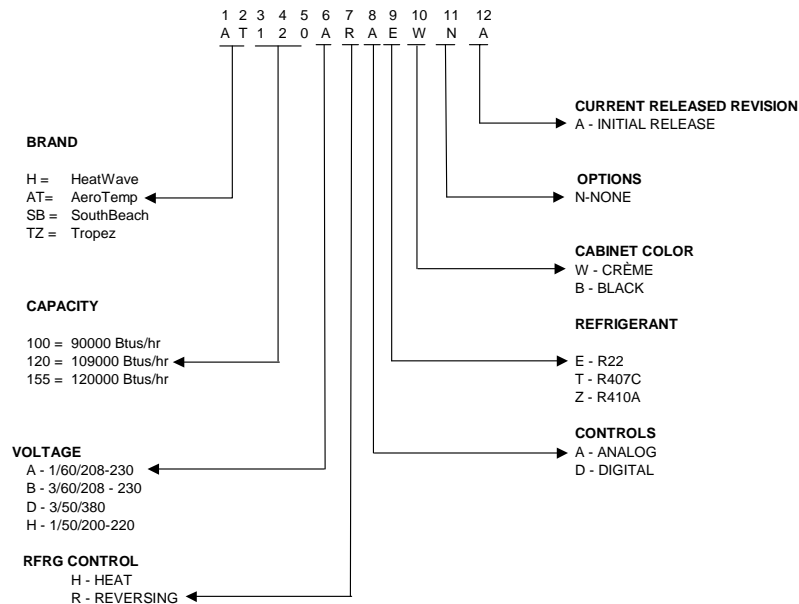

INSTALLATION

Placement of Heater

Indoor Installation

Indoor installations can be problematic, and for that reason are discouraged. However, if no viable alternative exists, indoor installations may be successfully accomplished provided very exacting criteria is addressed. Every indoor installation is unique; therefore, there are no specific guidelines for this type of installation. If considering an indoor installation, you are strongly urged to contact AquaCal Engineering or Technical departments (800-786-7751) for assistance prior to proceeding.

Outdoor Installation

Service and Operational Clearances:

- ◆ To operate correctly, heat pumps require large volumes of air moving over the heat collector. Allow adequate clearance between the heat pump and walls, fences, shrubs, or other objects. Refer to recommended clearance drawings below.
- ◆ Allow five (5) feet of vertical clearance between the top of the heat pump and any roof overhang or other obstruction. This clearance prevents cold discharge air from recirculating back into the heat pump (recirculation would reduce the overall performance of the heat pump).
- ◆ The access panel requires removal during installation and service. Do not place plumbing, or other items, closer than 30" from the front of the heater.

Code Required Clearances:

In addition to the previously stated clearance requirements, follow all applicable local, state, and national requirements relative to spacing from other objects or equipment.

Typical Installation Clearances

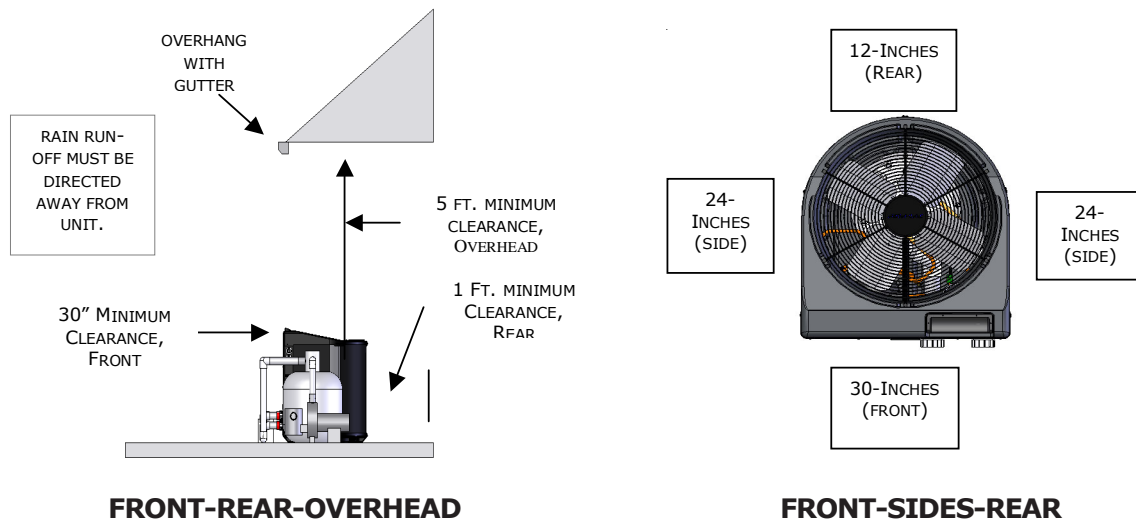

Irrigation, Rainwater Runoff, and Landscape Features:

Place the heat pump away from direct rain runoff from roofs. A gutter or rain shield may be required on the roof edge above the heat pump. Relocate or adjust irrigation to avoid water spray directly onto the heat pump. Do not locate the heat pump directly adjacent to plants, shrubs, or bushes. Doing so will prevent proper air circulation into the unit, and may inhibit access to the heater when service is needed. Consult drawings on previous page (*Recommended Installation Clearances*) for proper spacing to other objects.

Equipment Pad Requirements:

The equipment pad should be constructed of concrete, pressure treated wood, or other material intended for the use. The pad shall be elevated and placed to provide adequate drainage and support to the base of the heat pump. The pad should be essentially level with just enough pitch to drain condensate and any other water away from the heater. In addition, the pad shall extend—in all directions—at least 3" beyond the base of the heat pump. Under no circumstances shall the heater be installed directly onto the earth.

Anchoring Heater to Pad:

Follow all relevant local, state, or national requirements regarding wind load anchoring. When anchoring is required, use AquaCal optional Hurricane Anchoring Kit, PN: STK0001. AquaCal anchoring kits satisfy, completely, the very stringent Florida Building Code Section 301.13 wind anchoring requirements. As necessary, contact AquaCal Technical Support (800-786-7751) for assistance in determining best method of compliance.

Plumbing Requirements

Overview:

When planning plumbing system layout, reference the plumbing schematics following this section as a guide to the sequence of equipment, valves, fittings, etc. The plumbing configurations for typical installations are diagrammed. In operation, it is imperative the heat pump receive water flow within the minimum-maximum ranges specified for the particular heat pump. Should the system installation under consideration not closely match any of the schematics, contact AquaCal Technical Support for advice and guidance: (800) 786-7751.

Parts and Materials:

Industry technology changes much too rapidly for AquaCal to specify, with exactness, any items outside and beyond the heat pump. What is specified is that the heater must be installed in accordance with all applicable local, state, or national codes & standards.

Water Connections to Heat Pump:

All Heat Wave and AeroTemp heat pumps are supplied with 2" PVC plumbing unions. Connection to site plumbing is made via PVC solvent cement to the female slip socket of the plumbing unions.

Maintain Ability to Winterize:

In regions where hard winters are typical, the unions mentioned above allow for easy disconnection/reconnection of the heater from/to the plumbing system. Caution: Do not defeat the function of the unions—use no glue on the threaded portion of the unions.

Maximum Operating Pressure: 50 PSI

Minimum/Maximum Water Flow Rates:

All Heat Wave and AeroTemp models are designed to operate successfully between flow rates of 20-to-70 gallons-per-minute (GPM). Design the plumbing system to maintain at least 20-GPM flow through the heater; the heat pump will not operate correctly, nor reliably, with less than 20-GPM of water flow supplied. If water flow rates through the heater will exceed 70-GPM, a 5-lb spring-check bypass valve (AquaCal P.N.: 2556) will be required; generally speaking, most residential pools and spas will not require a bypass unless a pump of two (2) horsepower or larger is used (for bypass valve placement details, see plumbing schematic contained on next page: "...Flow Greater than 70-GPM").

Plumbing Schematic–Flow Exceeding 70-GPM

CAUTION !

Failure to heed the following may result in damage to equipment.

Use of an incorrect bypass valve may compromise the heat pump's efficiency, reliability, and may void the factory warranty. When using a bypass valve, order and install only an AquaCal PN: 2556 spring-check bypass valve.

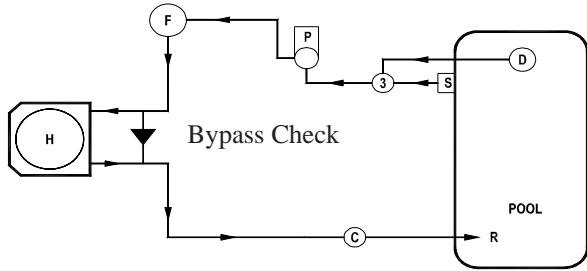

Typical Pool - Flow greater than 70 g.p.m. - (2 HP Pump)

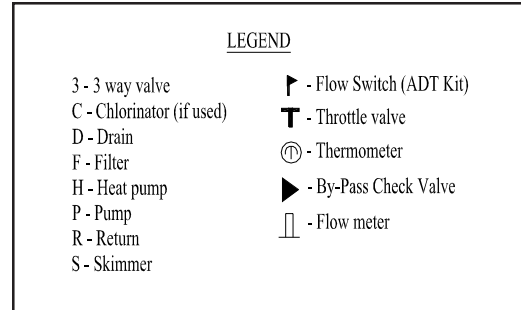

Plumbing Schematics–Flow 70-GPM and Below

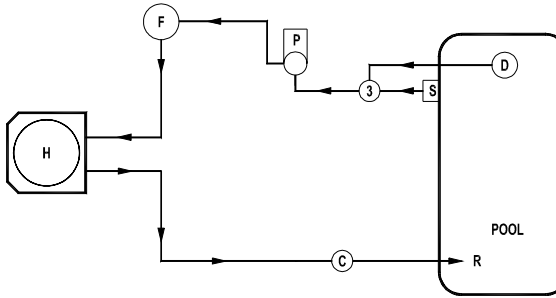

Typical Pool - Flow less than 70 g.p.m.

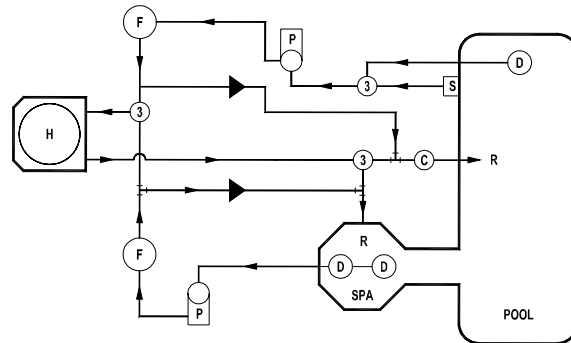

Pool/Spill over Spa - Two Pump System

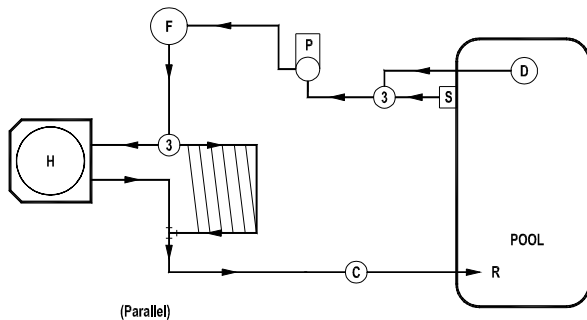

Heat Pump w/ Solar Panels

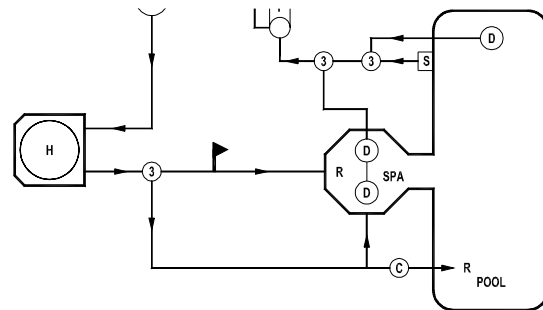

Pool/Spill over Spa - One Pump System

Plumbing Schematics—Flow 70-GPM and Below (continued)

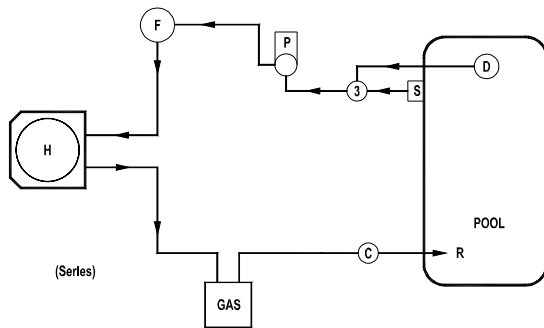

Heat Pump w/ Gas Heater backup

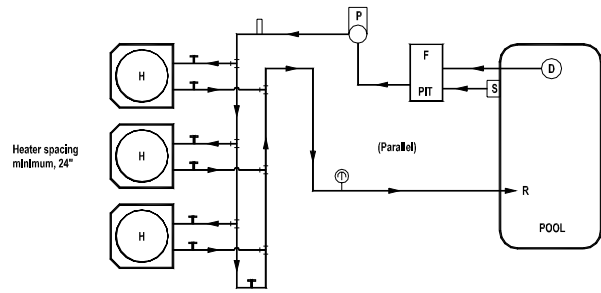

Multiple Heat Pump Installation

LEGEND	
3 - 3 way valve	▶ - Flow Switch (ADT Kit)
C - Chlorinator (if used)	T - Throttle valve
D - Drain	⊕ - Thermometer
F - Filter	▶ - By-Pass Check Valve
H - Heat pump	⏏ - Flow meter
P - Pump	
R - Return	
S - Skimmer	

Water IN & OUT Connections:

For proper operation and maximum efficiency, piping coming from the pump and filter **MUST** be connected to the "IN" port of the heater. Likewise, connect piping returning to the pool/spa to the "OUT" port of the heater. See drawing below.

PLUMBING CONNECTION DETAIL

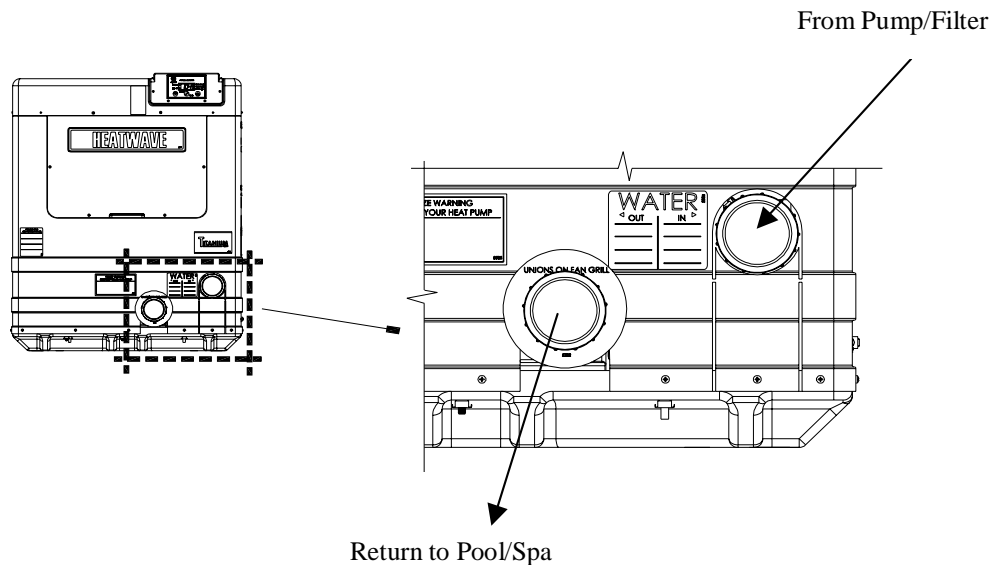

Electrical Requirements

WARNING!

Failure to heed the following may result in permanent injury or death.

Installation made by unqualified persons can result in hazards to the installer and others. The information contained in this Electrical Installation section is intended for use by qualified electrical installation technicians, familiar with electrical service industry safety standards and methods. Electrical installation to be performed by qualified individuals only.

General Requirements:

- ◆ When possible, locate the equipment disconnect means within arm's reach of the heater's electrical enclosure or as close as possible to the heater. Always satisfy applicable codes and standards.
- ◆ All AquaCal heat pumps are designed for copper conductors, only.
- ◆ In sizing power wiring, be especially aware of up-sizing requirements necessary due to wiring distances. Always satisfy applicable codes and standards.
- ◆ Multiple heaters installed at same site generally require special sequencing controls (AquaCal P.N.: ASC-(+number of heaters)); if yours is a multi-heater installation, contact AquaCal Technical Support (800-786-7751) for application assistance.
- ◆ Electrical installation should be by licensed electrician only.

Code-Specific Requirements:

- ◆ The electrical installation must conform to the most current version of the National Electrical Code, NFPA No. 70, and all applicable local and state codes.
- ◆ National Electrical Code, Article 680; Swimming Pools, Fountains, and Similar Installations, shall apply.
- ◆ National Electrical Code, Article 440, Air-Conditioning and Refrigeration Equipment, shall apply.

Connecting External Controllers:

- ◆ See document entitled: "Connecting External Controllers to AquaCal Heat Pumps". This document is shipped inside heater, accompanying the electrical schematic. (For *Call-Flex* option, contact AquaCal Technical Support. All other controllers, reference document, per above, shipped with heater.)

Reference Equipment Data Plate:

- ◆ All Heat Wave and AeroTemp heat pumps have two (2) identical data plates affixed: one can be found outside the unit, on right front side of fan top; the second data plate is located within the unit, on the electrical enclosure cover. Refer to either equipment data plate for unit-specific electrical power supply requirements. Based on data plate information; size wiring, wiring devices, and over-current protection per applicable codes and standards.
- ◆ Refer to drawing below for data plate items specific to electrical installation requirements. On the actual heater data plate, the areas depicted below (1-8) will contain the necessary information required in sizing electrical service and over-current protection.

ELECTRICAL PORTION of DATA PLATE

MINIMUM CIRCUIT AMPACITY	#1	Hz	#2	MADE IN THE USA	
ELEC. SERVICE: Vac ~	#3	PHASE	#4		
MAXIMUM TIME DELAY FUSE OR HACR BREAKER	#5				
COMPRESSOR Vac		R.L.A.	#6	L.R.A.	#7
FAN MOTOR Vac		H.P.		F.L.A.	#8

START-UP & OPERATION

Getting Familiar with Controls

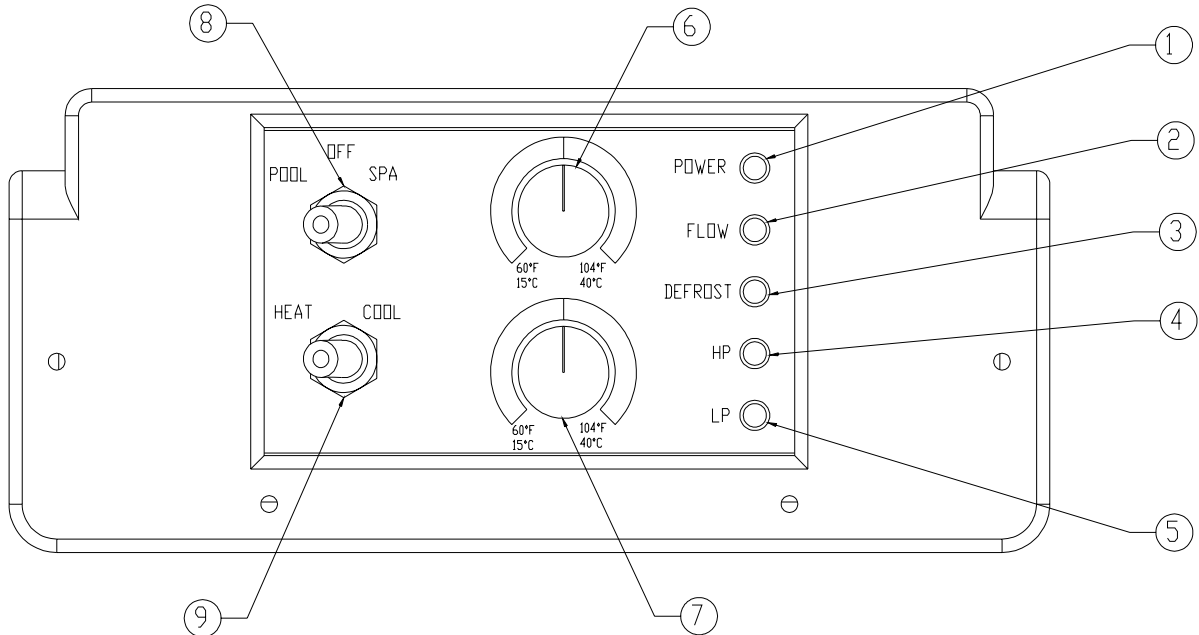

Heat Wave/AeroTemp 100R & 120R Control Panel Features

- 1) **POWER LIGHT** – Indicates electrical power is supplied to the heater.
- 2) **FLOW LIGHT** – Indicates water pressure (flow) is present at the heater.
- 3) **DEFROST LIGHT** – Indicates heater is in the defrost mode.
- 4) **HIGH REFRIGERANT PRESSURE** – Indicates excessively high refrigerant pressure. Heater may not be receiving adequate water flow.
- 5) **LOW REFRIGERANT PRESSURE** – Indicates abnormally low refrigerant pressure.
- 6) **POOL TEMPERATURE CONTROL** – Controls POOL temperature set-point.
- 7) **SPA TEMPERATURE CONTROL** – Controls SPA temperature set-point.
- 8) **POOL/OFF/SPA SELECTOR SWITCH** – Selects between POOL and SPA thermostats, or OFF position.
- 9) **HEAT/COOL SELECTOR SWITCH** – Selects either HEATING or COOLING.

Overview of Controls

(Please refer to control panel diagram on previous page.)

POOL/OFF/SPA (P/O/S) Toggle Switch and Sequence of Operation

With the toggle switch in the OFF (O) position, the heater will be prevented from operating (however, there may be power to the unit; see "Power Light On", below). With the toggle switch positioned toward the SPA or POOL thermostat knob, with HEAT selected, and with the following conditions met: 1) water pump in operation, with water flowing through the heater, and, 2) electrical power to the heater, the heater will run if the water temperature drops below the thermostat setting. If COOL is selected, the heater will operate if the water temperature rises above the thermostat set point.

Note- In Heat Mode, Heater Can Start with Thermostats Set to Minimum:

With proper water flow and electrical power supplied to the heater, and either the POOL or SPA thermostat selected and set to minimum, the heater will operate if the water temperature falls below 60° F. Likewise, if mode is set to COOL, with thermostats set to *maximum*, and in the unlikely event the water temperature rises above 104° F, the heat pump *will* operate to cool the water to a point below 104° F. If heat pump operation is absolutely not desired, position the POOL/OFF/SPA toggle switch to the middle, OFF position.

Power Light On

Indicates electrical power is supplied to the heater. The heat pump will start if the selected (POOL or SPA) thermostat calls for heating or cooling, and there is proper water flow through the heater.

Power Light Off

Indicates proper electrical power is not supplied to the heater. If attempting to operate the heater, ensure all heater-related disconnect switches and/or circuit breakers are switched to the ON position.

Flow Light On

Indicates sufficient water flow to permit the heater to operate. The heat pump will start upon a call for heating or cooling.

Initial Start-Up and Basic Operation

(Please refer to "Overview of Controls", above, before continuing.)

1. Set P/O/S Toggle Switch to OFF—Lower or Raise Thermostat Settings:

- ◆ Position the POOL/OFF/SPA toggle switch to "OFF".
- ◆ If preparing to HEAT, turn both thermostat knobs counterclockwise to lowest settings. If preparing to COOL, turn both thermostat knobs clockwise to highest settings.

2. Establish Water Flow and Electrical Power to the Heat Pump:

- ◆ With circulator pump off, position the water valves to heat or cool either the pool or the spa. If system is equipped with an external pump/valve/heater controller, simply use controller to position valves to pool or spa setting, and to start the appropriate water pump.
- ◆ Ensure any heat pump-related disconnect switches, or circuit breakers, are switched to the ON position.
- ◆ If not already operating, start the pool or spa pump (depending of which body of water is to be heated or cooled), permitting the pump to operate for a few minutes before going on to next step. This wait is necessary to clear any air that may exist in the water piping.
- ◆ The heat pump will not start without electrical power and water flowing through it. At this point, the power light and flow lights should be illuminated.

3. **Select POOL or SPA & HEAT or COOL, Raise or Lower Associated Thermostat:**

- ◆ Position the POOL/OFF/SPA toggle towards the POOL or SPA thermostat knob (depending on which body of water you are preparing to heat or cool).
- ◆ For Heating, move HEAT/COOL toggle to HEAT, then turn the selected pool or spa thermostat dial clockwise to its highest setting. As soon as the thermostat setting is above the temperature of the water, the heat pump will begin to operate. See note below if heater does not start immediately.
- ◆ For Cooling, move HEAT/COOL toggle to COOL, then turn the selected pool or spa thermostat dial counterclockwise to its lowest setting. As soon as the thermostat setting is below the temperature of the water, the heat pump will begin to operate. See note below if heater does not start immediately.

Note- Heater Controls Contain a Solid-State Time Delay Module

This time delay feature prevents damage to the compressor should electrical power be repeatedly interrupted, or if the heat pump were to come under any other circumstances leading to an on-off-on-off cycling condition. If the heater has water flow and electrical power supplied, but the heater does not immediately start upon turning the thermostat to its highest (or for cooling, lowest) setting, wait five (5) minutes; the time delay module may be preventing the heater from operating. Likewise, once the heater is operating, if the thermostat is turned past the present water temperature, the heat pump will shut off. Subsequently, the heater cannot restart for approximately five (5) minutes—no matter how far the thermostat is rotated.

4. **Ensure Uninterrupted Pump Operation During Initial Warm-Up or Cool-Down Period:**

- ◆ Permit pool or spa circulator pump to run continuously until the desired water temperature is reached (with a pool, this may take several days).
- ◆ Continuous pump operation will likely require temporarily resetting (or removing completely) the trippers on the time clock, thus allowing nonstop operation. When an external electronic controller operates pumps and valves, follow the controller manufacturer's instructions to ensure temporary, uninterrupted pump operation.
- ◆ Throughout the warm-up or cool-down period, keep the selected pool or spa thermostat dial set to its maximum heating or cooling position.

5. **Desired Water Temperature Reached— Set Thermostat to Maintain:**

- ◆ If Heating, once the desired water temperature has been achieved, rotate the thermostat knob *very* slowly counterclockwise until the unit (just) shuts off.
- ◆ If Cooling, once the desired water temperature has been achieved, rotate the thermostat knob *very* slowly clockwise until the unit (just) shuts off.
- ◆ The heater will automatically maintain the pool or spa at the selected temperature.

6. **Return Pump Timer Controls to Normal Settings:**

- ◆ Reset pump timer controls for normal daily hours of operation.
- ◆ During cooler or cold weather conditions, it may become necessary to extend the daily hours of pump operation; doing so will help the heater to keep up with increased heat losses. Extending pump operation hours for cooling is not generally required.
- ◆ Also see next topic: "Heating Tips," following on next page.

Heating Tips

WARNING!

Failure to heed the following may result in permanent injury or death.

Improperly used, Pool-Spa solar blankets can become a drowning risk to people and pets. Solar blankets are not safety covers. They are not designed to support the weight of a person or pet. Never enter a pool until the solar cover is completely removed (under no circumstances should anyone swim under the blanket). Follow all safety recommendations of the blanket manufacturer.

Pool/Spa Blankets

A solar blanket will significantly reduce your heating bills. Check with the installing dealer to see if your heat pump was sized to be used in conjunction with, or without a solar blanket. Blanketed pools will typically lose only 3 - 4° of heat per night versus 8 - 10° overnight with an un-blanketed pool. Reductions of 40 - 60% on heating bills can be achieved by using solar blankets.

Pool and Spa Combination Heating

Everything stated for heating a pool applies for heating a spa; only the volume of water being heated is different. Heat Wave and AeroTemp model heat pumps come equipped with two thermostats. One thermostat is for the pool and the other is for the spa. Simply position the pool and spa isolation valves as directed by your installer; select the appropriate thermostat (pool or spa), whichever you are heating, and with electrical power and water flow supplied to the heater, the water will be maintained at set point.

Your system can be automated with the addition of an optional AquaCal Universal Heater Controller (AquaCal part #0097TS). Using this option will save you from having to change the thermostat switch each time you change from pool to spa and back again. For details, contact your installing dealer.

Spa Heating & Spa Setback Option

Air blowing into your spa while it is being heated will very often neutralize or partially counteract the heat being put into the spa by the heater; this added heat loss equates to increased time to bring your spa to desired temperature. When heating a spa, be sure to turn off the air blower. Air induced through the spa jets should also be eliminated, during warm-up, whenever possible.

If your heater is being used to *only* heat a spa, the POOL thermostat can be used as a setback control: simply set the pool control at a point 10-15° F below desired spa heat temperature, and select the pool thermostat. This method allows the spa—when not in use—to be held at a heated temperature, but somewhat lower than normal spa-use temperature. One would want to blanket the spa if using this setback method. Using spa setback will result in reduced warm-up periods over full-cold start ups.

Heating in Cooler Weather (Defrost Cycle)

When air temperatures drop below 50° F, ice or frost may begin to form on the surface of the evaporator (the evaporator being the black, vertically-finned component that makes up three (3) sides of the heat pump). Ice and frost formation is a normal aspect of heat pump operation during cold weather. Before large areas of the evaporator can become disabled by ice or frost, a defrost cycle is initiated by a sensor on the evaporator. Heat Wave and AeroTemp *Icebreaker* models incorporate an active, hot-gas defrost system. During very cold weather, *Icebreaker* heat pumps may defrost as often as every 50-minutes. The maximum length of time the heat pump will be in the defrost mode is ten (10) minutes/hour. While defrosting, steam may be seen rising from the heat pump; this is normal. (For service personnel, a more detailed explanation of the defrost cycle appears in the Troubleshooting section of this manual.)

Late night and early morning, generally being the coolest times of the day, are least efficient for heat pump operation. The need to defrost is a very good reason why heat pumps should be timed to operate only during the warmest, daylight portions of the day.

Calculating Initial Heating Time

The time it takes to initially warm your pool or spa depends on several factors. First determine how many gallons of water are to be heated. Knowing this, you can then compute the equivalent pounds of water involved, and the BTU's necessary to heat the volume of water to the desired temperature. Next, find the approximate BTU output of your heat pump at the current ambient air temperature (see specifications table in this manual). Finally, decide upon the temperature at which you plan to maintain your pool or spa.

Sounds complicated, but it's not! The following work sheet can be used to calculate approximately how long it will take your heater to bring your pool or spa up to temperature. Keep in mind that heating times will vary somewhat due to weather conditions during the period that the heater is in use.

Volume of Pool (Length X Width X Average Depth) = _____ Pool Cubic Feet

X Gallons per cubic ft.(7.5) = _____ Pool Gallonage

X Pounds per Gallon (8.3) = _____ Pounds of Water

How many degrees do you want to raise the temperature of the pool?

of Degrees _____ X Pounds of Water (per above) = _____ BTU's Required

BTU's Required (per above) _____ ÷ BTU Output of Heater = _____ Hrs. of Operation

Optional Cold Weather Adjustment Factor:

Hrs. of Operation (per above) _____ X 1.25 (60° F outside air (O.A.) Temperature Factor) = _____
Hrs. of Operation at 60° F O.A.

When you start your AquaCal heat pump for the first time, the heat pump must be permitted to operate, continuously, until the desired water temperature is attained. This may take several hours, to several days, depending upon the time of the year and weather conditions. If a time clock or similar device controls the operating time of the circulator pump, temporarily override the time clock or controlling device to allow for 24-hour, continuous water pump operation.

Once the body of water is up to temperature, the time clock can be reset. A heat pump is a maintainer of heat, and thus is sized to overcome heat losses. However, during the colder months, when heat losses are at their greatest, and in order to keep up with increased heat losses, water pump run times may need to be extended.

Since air is generally at its warmest during the daytime, it is best to operate heat pumps during the daytime when there is more heat to transfer. Whenever possible, set system run times for daylight hours.

NOTE: An optional Call Flex Time Clock Manager (AquaCal part #0030S) can eliminate the need to change water pump run times as heat losses change with weather conditions. Please contact your installing dealer for details.

MAINTENANCE

The information in this section is written primarily for the Home Owner, but may also apply to servicing dealers or HVAC service centers. This section contains information concerning planned maintenance, proper water flow, maintaining proper clearances, as well as other vital information. Please read this section now, and before calling AquaCal Customer Support (800-786-7751).

Planned Maintenance Program

Just as you would have yearly service performed on your air-conditioning system, regular inspection & maintenance of your AquaCal heat pump will insure highest operating efficiencies, while also protecting your investment—potentially extending the useful life of your heat pump far beyond the warranty period. Our expertly trained factory service technicians offer comprehensive maintenance procedures that will insure your heat pump operates efficiently and reliably when you need it to.

The 20-Point Planned Maintenance Service Includes the Following:

- > Check Water Flow
- > Clean Evaporator Coil
- > Check Relay Contacts
- > Check Capacitor Values
- > Check Refrigerant Levels
- > Clean Heat Pump Cabinet
- > Check Fan Blade Clearances
- > Check Flow/Pressure Switch
- > Check Electrical Connections
- > Check Proper Voltage To Unit
- > Oil Fan Motor (As Applicable)
- > Check Fan Motor Amperage Draw
- > Check Pool & Spa Water Chemistry
- > Check and Clean Condensate Drains
- > Check Compressor Amperage Draw
- > Check Water Pump Amperage Draw
- > Acid Wash Source Coil (As Applicable)
- > Check Operating Controls and Temperature Sensors
- > Check Air Temperature Change Through Evaporator
- > Check Water Temperature Change Through Condenser

We recommend all AquaCal heat pump owners take advantage of this annual service starting one year after the installation of the unit. You will be surprised at the minimal cost of this service—the service is very reasonably priced for what is included. For further information, or to schedule Planned Maintenance Service, please contact AquaCal Customer Support at: 1-800-786-7751.

General Maintenance

Heat pumps should be inspected and maintained on an annual basis by a qualified swimming pool heat pump specialist. Additionally, if the heat pump is located on the beach, or at a sea wall where salt spray and sand can become detrimental factors, more frequent service may be necessary. For service plan information, please see: Planned Maintenance Program, on previous page, and then contact AquaCal Customer Support at: 800-786-7751.

While annual maintenance is recommended to maintain your warranty, if you choose not to participate in the Planned Maintenance Program, rinsing the air coil regularly, and keeping the base of the unit clear of leaves and debris is a necessity.

Should you as the owner desire to perform the coil rinsing and other cosmetic care of the heat pump, please contact AquaCal Customer Support: 1-800-786-7751; request the document entitled: Appearance Care for Air-Source Heat Pumps: Approved Method for Homeowners.

WARNING !

Failure to heed the following may result in permanent injury or death.

POSSIBLE ELECTRIC SHOCK HAZARD . . . Should you decide to wash the heat pump via water hose, disconnect all power to the pool equipment pad- including, but not limited to: The heat pump, water pump, and any and all other electrical equipment. Do NOT spray water directly into electrical components. Do NOT restore electrical power until such time as all water has dried completely.

CAUTION !

Failure to heed the following may result in damage to equipment.

Do not use a pressure cleaner to wash heat pump Damage to evaporator fins, as well as other components, will result.

- ◆ **Control Irrigation:** In regions where wells are used for irrigation, water quality is sometimes less than poor, and water spray can damage heater components. Regardless of water quality, it is important that irrigation be directed away from the heat pump.
- ◆ **Prevent rain water runoff,** from roofs, from pouring directly into the heater. The heater is designed to withstand normal rainfall, but solid streams of water from roof drip-lines may eventually damage heat pump components. If the heat pump resides beneath a roof edge, to promote heat pump longevity, a rain leader (gutter) or rain shield will be necessary.
- ◆ **Drainage:** Your heat pump may produce abundant condensation under certain conditions; this is considered normal operation. Accordingly, keep the drain holes at the base of the heat pump free of grass, weeds, dirt, or other obstructions, allowing for free and complete drainage around the heater.
- ◆ If the heat pump is located under trees, where leaves fall and accumulate in the bottom of the heat pump, a qualified technician should periodically remove accumulated leaves.

Maintaining Proper Water Flow

- ◆ It is important to operate and maintain the filter according to the manufacturer's specifications. As a filter gets dirty, the water flow to the heat pump is reduced. The higher the pressure on the filter gauge, the lower the flow rate.
- ◆ Similar to a dirty filter, large amounts of debris in the pump basket can reduce water flow. Keep basket free of debris.
- ◆ Check for improper valve settings. A partially closed valve after the filter, or a full-open bypass around the heater, will cause insufficient water flow through the heater.
- ◆ If the conditions listed above remain unresolved, the water flow through the heater may be reduced to a point where internal safety devices shut the heater off. Before calling for service, always check the filter, the pump basket, and water valve positions. If the problem persists, call AquaCal Customer Support at: (800) 786-7751.

CAUTION- Pool/Spa Refinishing Operations

During pool refinishing or acid cleaning, the water flow through the heater must be shut off. Water flow to the heater must remain off until water chemistry is once again in balance and the water is clear in appearance. Failure to follow these instructions may void heater warranty.

Maintaining Proper Clearances Around Heater

- ◆ For maximum efficiency, proper air flow clearances around heater must be maintained.
- ◆ It is important to keep the area immediately adjacent to the heat pump clear of items such as shrubs and bushes, lawn furniture, chemicals containers, etc. These items can prevent air from circulating fully through the heater, and will result in inefficient operation or damage to components inside the heat pump. In addition, do not place objects on top of the heat pump; doing so will block the air from exiting the heater, and will result in damage to the compressor and fan motor.
- ◆ Proper clearances are also necessary in order to access the working parts of your heater. A heater that is easy to "get to," will be a heater that is easy to maintain; service and maintenance personnel will thank you for keeping the area around your heater unobstructed.
- ◆ Please see: Service, and Operational Clearances, located within the Installation section of this manual, for specific clearance requirements.

SEASONAL USE & SHUT DOWN

During the Swim Season

- ◆ During the swim season, even if the pool or spa is not in use, allow water to flow through the heater. Doing so eliminates the need to reposition valves when you do wish to heat the pool or spa.
- ◆ During periods where heating or cooling is not desired, leave POOL/OFF/SPA toggle switch in the OFF position.

Freeze protection / Extended Shut Down

- ◆ In areas where freezing conditions are a rare occurrence, allow the filtration system to run continuously through the freeze period. Typically, during light freeze conditions, circulating water will not freeze.
- ◆ In areas where freezing conditions are prevalent, please refer to winterizing instructions following this section.

SEASONAL USE & SHUT DOWN (CONTINUED):

Winterizing (Hard Freeze Conditions)

WARNING !

Failure to heed the following may result in permanent injury or death.

To avoid injury from rotating equipment (fan blade), disconnect electrical power from heat pump before proceeding with INTERNAL DRAIN winterizing process.

CAUTION !

Failure to heed the following can result in damage to equipment and/or property.

Failure to properly winterize heat pump may result in serious equipment damage. Freeze damage is not covered under the heat pump warranty.

CAUTION !

Failure to heed the following can result in damage to equipment and/or property.

While the plumbing connections are in the winterized condition (not fully tightened), it is imperative pool/spa water not be circulated through the heat pump. Loss of water through loose plumbing connections may result in damage to circulating pump, pool/spa structure, and/or other equipment.

Winterizing a Heat Pump Equipped with an Internal Drain

(Per Figures 1 & 2, on page following)

1. Disconnect all electrical power to the heater; turn OFF circulating pump.
2. At the two (2) connection unions, disconnect the plumbing to the heater (removal is counterclockwise).
3. Remove the front plastic panel by removing the screws shown in Figure-1.
4. Locate the drain plug at base of the titanium condenser and remove (removal is counterclockwise). See Figure-2.
5. Permit all of the water to drain out of the condenser and then, threading clockwise, replace the plug finger-tight.
6. Reinstall the heater front cover and secure with attaching screws previously removed.
7. To prevent insects and vermin from entering the plumbing during the winterized period, partially reconnect the two (2) plumbing connection unions. Couple each union one or two threads; this will permit condensation to drain, but will prevent most insects and animals from entering the plumbing circuit.
8. Next Season: To ready the heat pump for use, simply retighten plumbing connection unions. Hand-tight is generally sufficient.

Winterizing a Heat Pump Equipped with an Internal Drain (Continued)

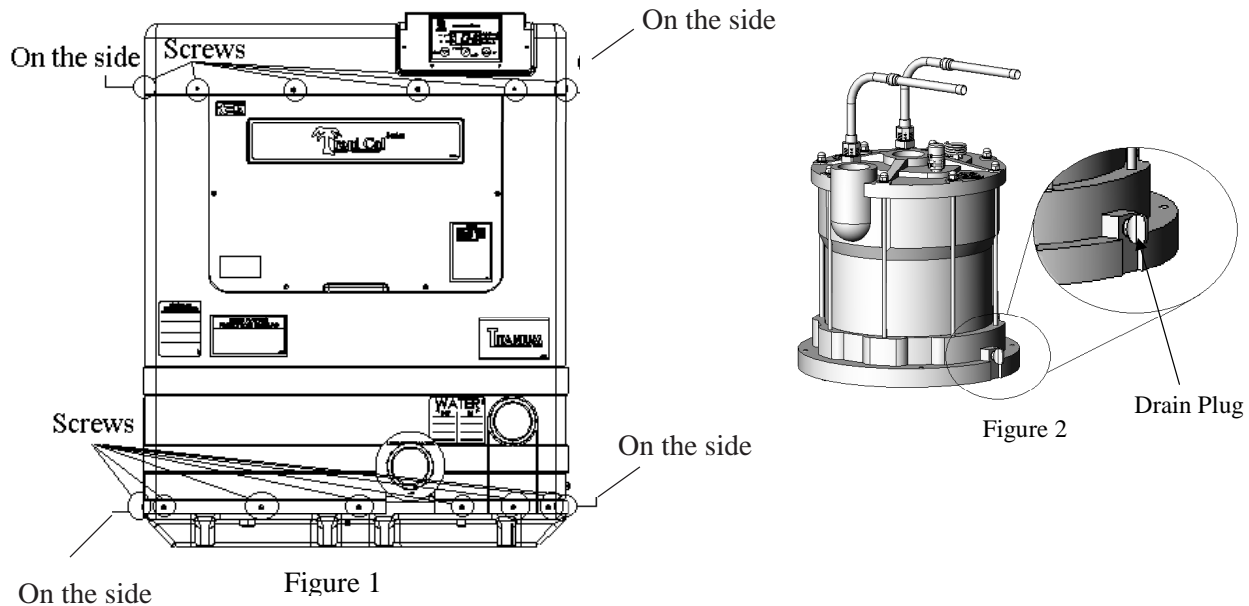

Internal Winterizing Drain

Winterizing a Heat Pump Equipped with an External Drain (Per Figure-3, on page following)

1. Disconnect all electrical power to the heater; turn OFF circulating pump.
2. At the two (2) connection unions, disconnect the plumbing to the heater (removal is counterclockwise).
3. Locate the drain plug at lower, right-hand, front corner of heater. See Figure-3.
4. Using a 5/8", box-end wrench, remove the drain plug (removal is counterclockwise).
5. Permit all of the water to drain out of the condenser and then replace the plug: thread the plug in clockwise until just snug, then apply an additional 1/8 turn.
6. To prevent insects and vermin from entering the plumbing during the winterized period, partially reconnect the two (2) plumbing connection unions: couple each union one or two threads; this will permit condensation to drain, but will prevent most insects and animals from entering the plumbing circuit.
7. Next Season: To ready the heat pump for use, simply retighten plumbing connection unions. Hand-tight is generally sufficient.

Winterizing a Heat Pump Equipped with an External Drain (Continued)

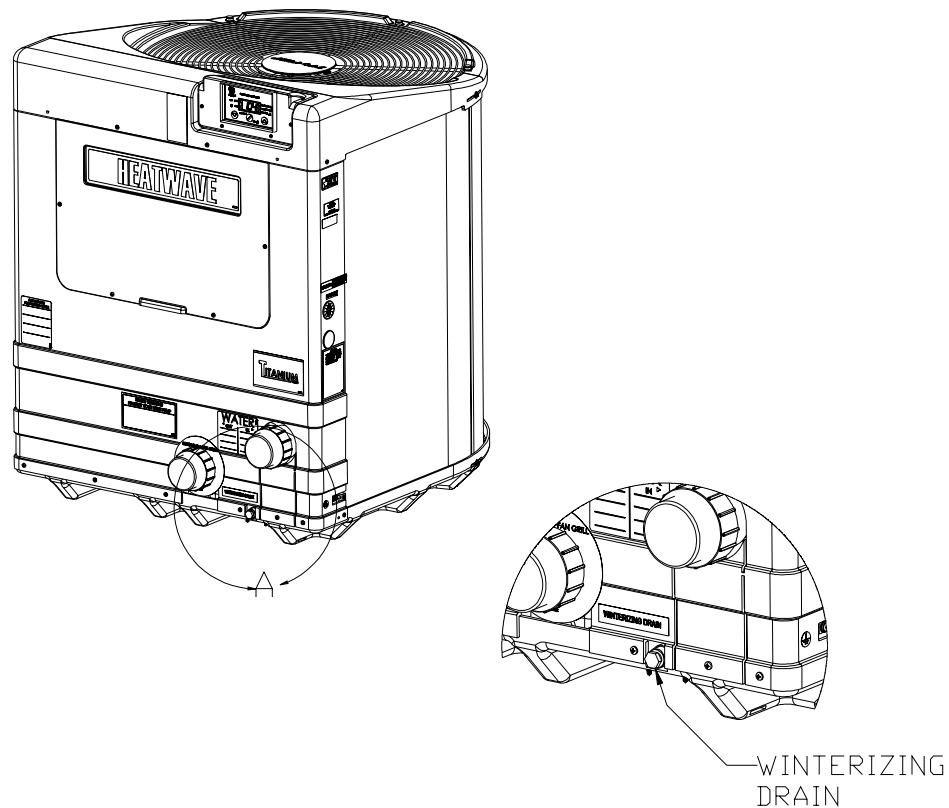

FIGURE 3
External Winterizing Drain

CAUTION !

Failure to heed the following can result in damage to equipment and/or property.

While the plumbing connections are in the winterized condition (not fully tightened), it is imperative pool/spa water not be circulated through the heat pump. Loss of water through loose plumbing connections may result in damage to circulating pump, pool-spa structure, and/or other equipment.

TROUBLESHOOTING

Common Troubleshooting Issues

Heat Pump Not Running

Is the power light lit?

If not, ensure the main breaker (located at the power supply panel) and the disconnect switch (located near the heat pump) are both turned ON.

Is the flow light lit?

If not, check to be sure that the circulating pump is operating and the filter is clean. There may also be a valve positioned incorrectly allowing water to bypass the heat pump. Be sure water is flowing through the heater.

Is the Pool or Spa thermostat selected, and have you tried turning the selected thermostat to a higher temperature setting?

If not, the actual water temperature may be above that of the selected thermostat. Raise the desired water temperature above the actual water temperature; the heater should start after an approximate five (5) minute delay. If the heat pump still fails to start, and the unit is not in defrost (defrost light lit), contact AquaCal Customer Support: 800-786-7751.

Heat Pump Running but Not Heating

Is the air blowing out of the top of the unit noticeably cooler than the surrounding air?

(A 9°F to 12°F difference is typical.) If not, contact AquaCal for service at: 800-786-7751. But first, be sure all air coil surfaces are free from obstructions—low roof overhangs, landscaping, walls, fences, etc., can restrict air flow. The heat pump needs good airflow to operate at peak efficiency.

How many hours/day does the circulating pump operate?

Cooler weather conditions, or heating to a higher temperature, may necessitate running the heat pump for a longer period of time. Was the heater sized considering the use of a solar blanket (check with installing dealer)? A blanket can be useful in permitting shorter run times, in turn leading to substantial energy cost savings.

What is the air temperature?

The heat pump may be in the defrost mode if air temperatures are below 50°F. The defrost light will be lit if the heater is defrosting. If air temperatures are not cold, but the defrost light is still illuminated, contact AquaCal Customer Support at: 800-786-7751.

Water Coming from the Heat Pump

Is it a leak or just condensation from normal operation? Here's how to find out.

Shut the heat pump off, leaving the circulation pump running. Within a few hours, there should be a marked reduction in the amount of water seen around the bottom of the heat pump. If the water appears to be drying up, the water is probably harmless condensate.

Or, as an alternate method, test the water draining out the heater base for the presence of the sanitizer being used in the pool or spa. Using a water test kit, or a test strip, check a sample of the water for chlorine or bromine. If the sample tests positive for sanitizer, call AquaCal for service at: 800-786-7751. If the test is negative, the water is probably harmless condensate.

NOTE: The water test method will not be effective if an ionizer or ozone generator is being used to produce the sanitizing agent.

Please see Troubleshooting Flowcharts, following, for more detailed information.

Troubleshooting Flow Charts

Heater Fails to Operate

Analog Controls - 12/22/03

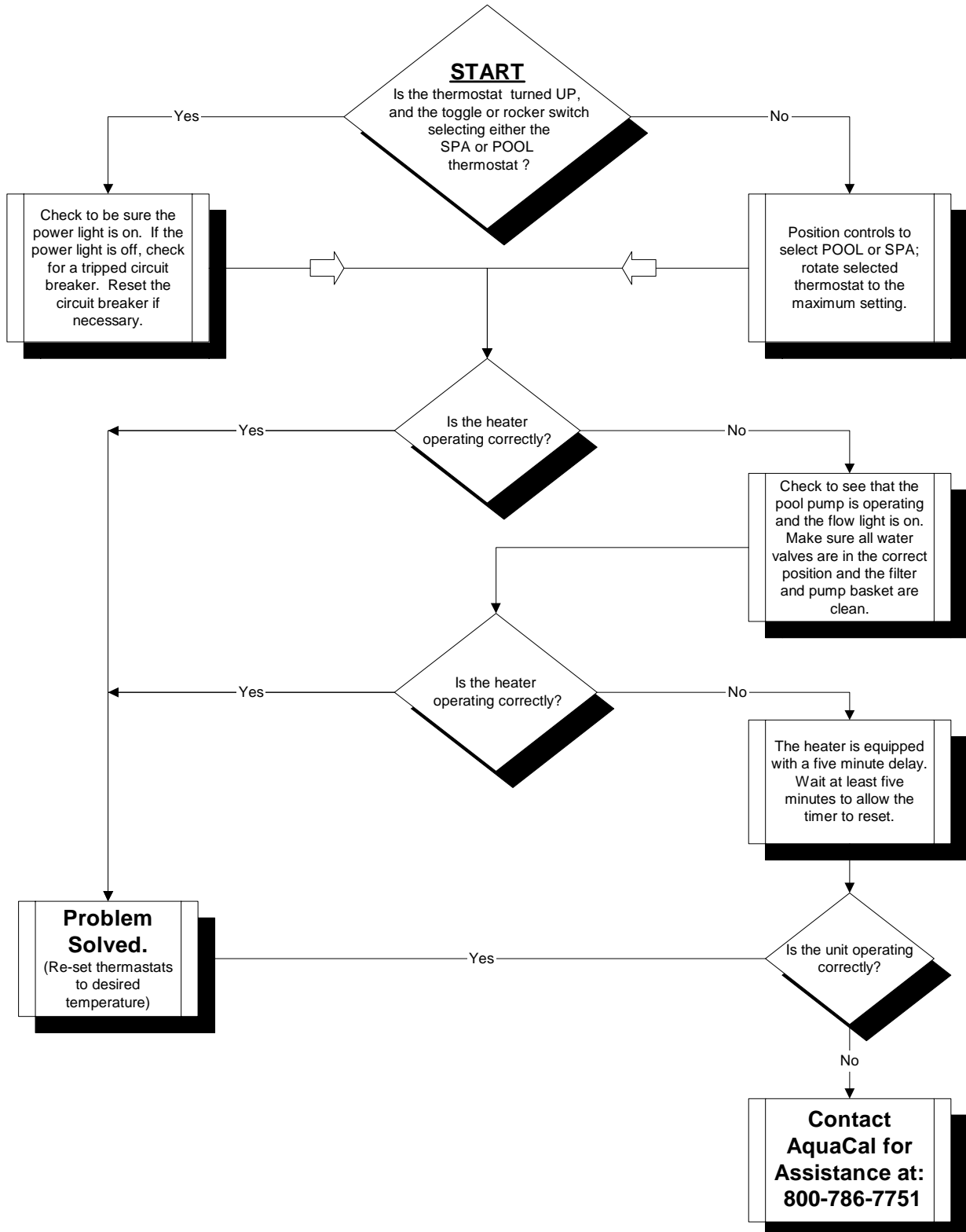

Heater Running but Not Heating

Icebreaker Analog Controls - 1/20/04

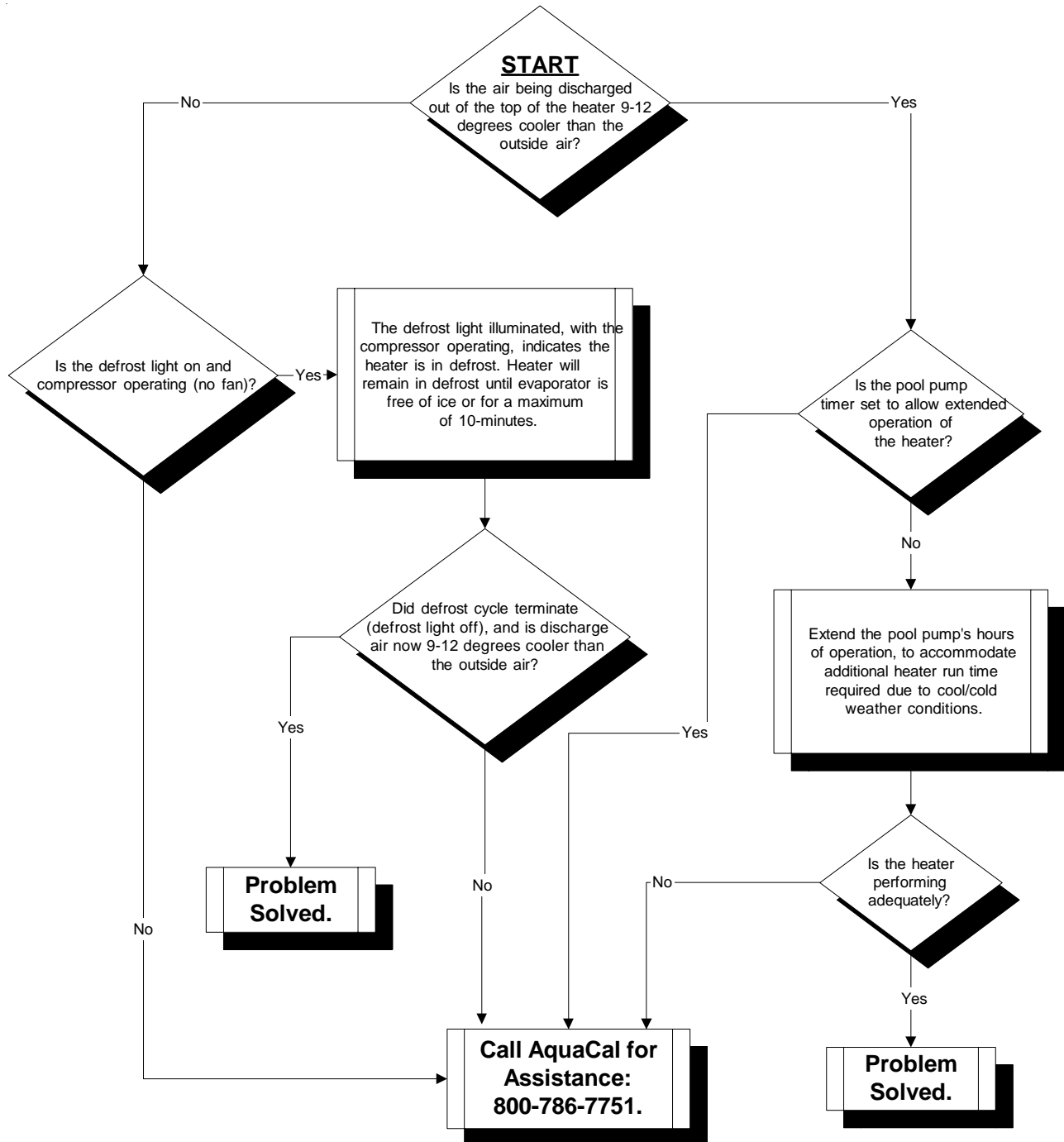

Determining Water Leaks vs. Condensation

All Analog/Digital Air Source Heat Pumps - 12/22/03

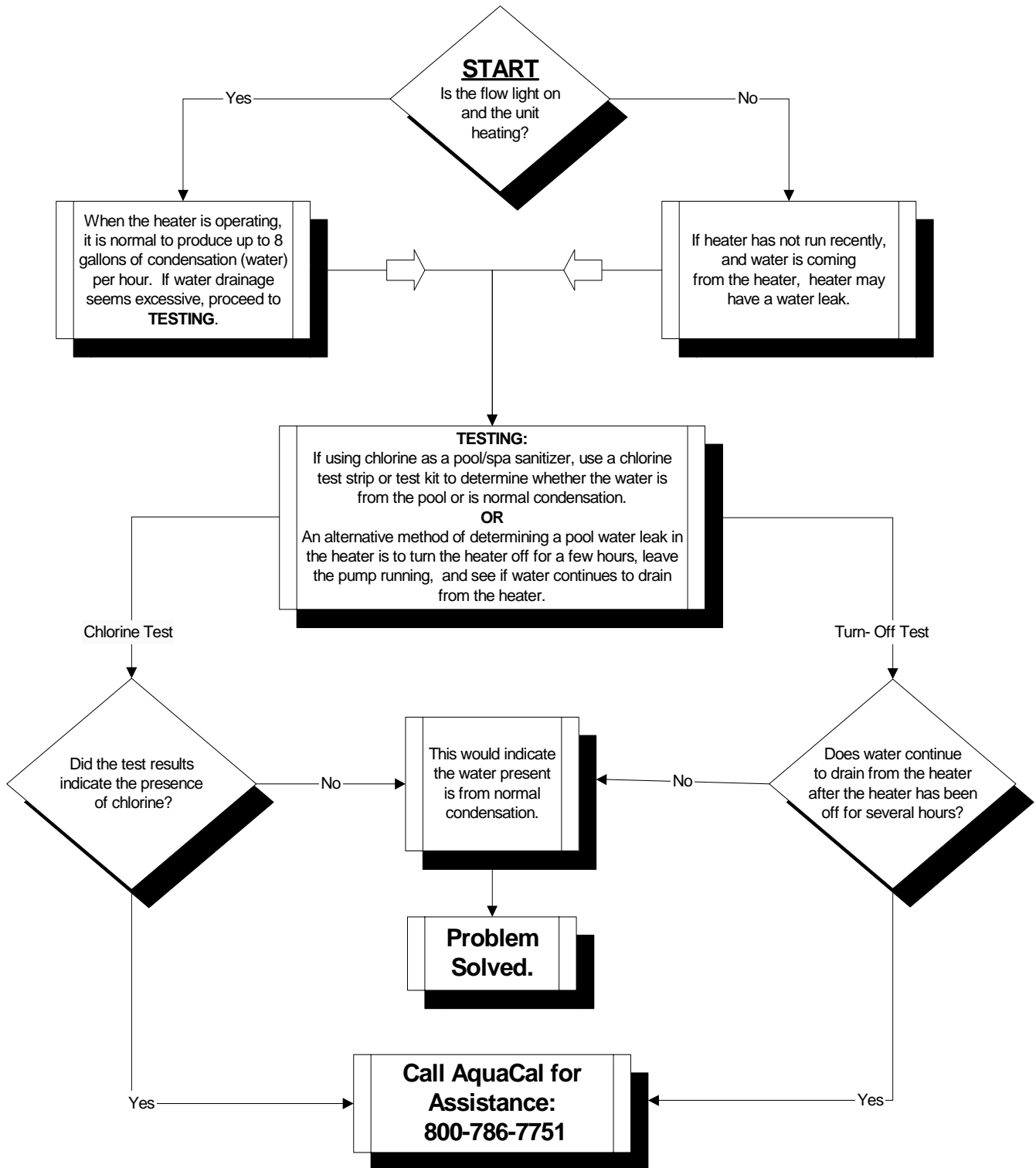

Heater Short Cycling

Analog Controls - 12/22/03

DANGER

* Any operation described in this flow chart, requiring the heater access panel be removed, MUST be performed only by authorized service personnel.

START

If the heater is turning on and off every 5 minutes:
Make sure all water valves are in the correct position, allowing water to flow through the heater. Be sure filters and pump skimmer baskets are clean. Check to be sure the water level in the pool is not below the skimmer.

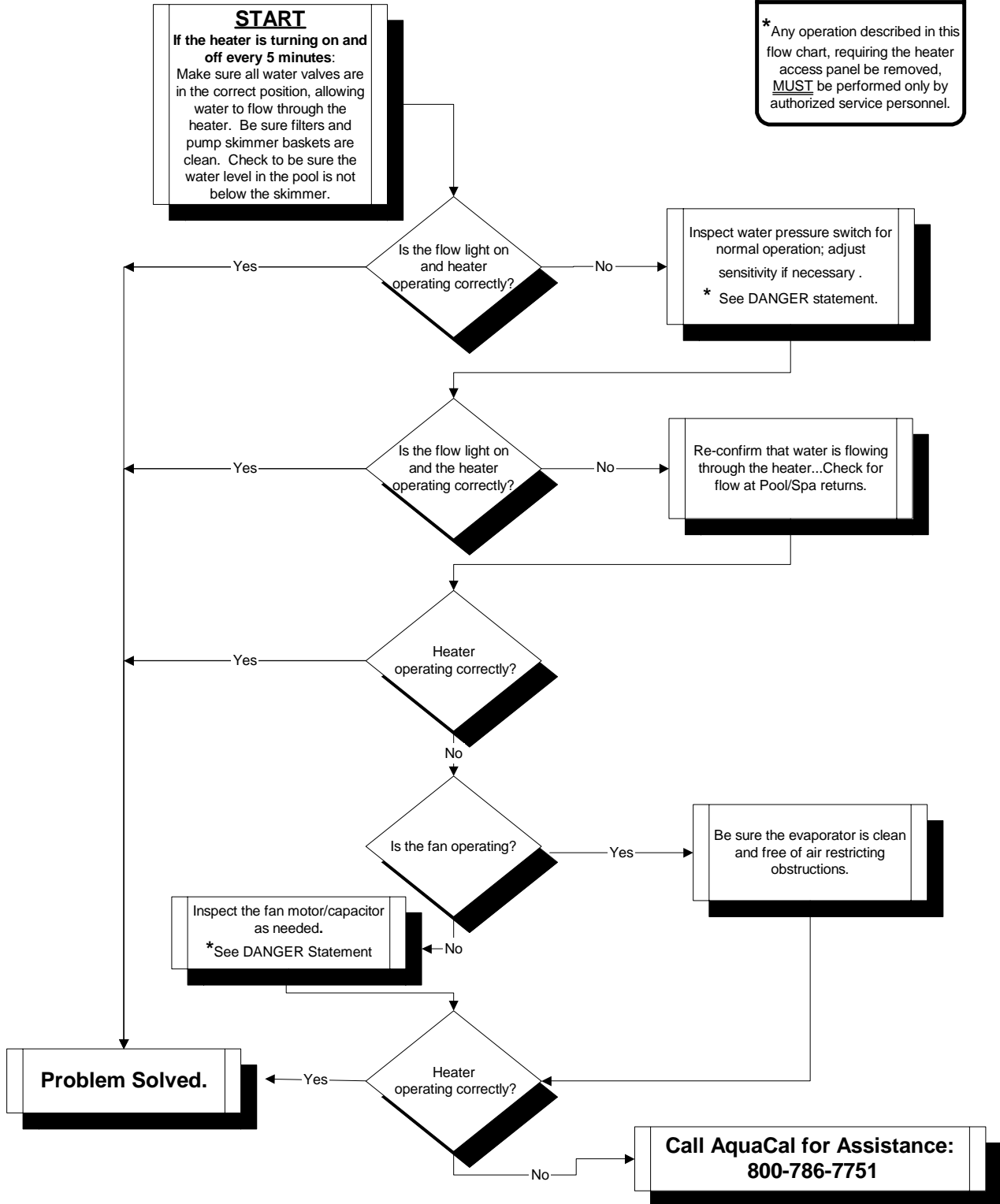

Water Flow (Pressure) Switch Adjustment

Occasionally, plumbing system design features will create a situation whereas the heater will abnormally cycle on the water flow circuit. This situation will be evident if the circulator pump is operating, the filter is clean, and all water valves are set to flow water through the heater—but the control panel FLOW light is not illuminated (or lights only intermittently). In these rare instances where the factory water pressure switch setting will not satisfy site conditions, a switch adjustment is possible to enable normal heater operation.

WARNING!

Failure to heed the following may result in permanent injury or death.

Adjustment procedure to be performed by experienced service personnel only; procedure is NOT a homeowner-based task, and must not be attempted by individuals lacking adequate electrical and mechanical experience. BEWARE: ROTATING FAN PROPHAZARD: fan may start during water switch adjustment. Keep hands clear of fan blade at all times.

Water Switch Adjustment Procedure:

1. Before proceeding with switch adjustment, be absolutely certain the heater is receiving correct water flow. Leave circulation pump operating during water pressure switch (WPS) adjustment process.
2. Remove heater front cover, and locate the water pressure switch. The switch is attached outside of the electrical enclosure, at lower left corner (see photo P-1, located on page following).
3. Heat Wave and AeroTemp heat pumps may come equipped with either of two (2) water pressure switches: “Len Gordon” or “TecMark” brand (see photos P-2 and P-3 to determine which brand pressure switch is installed). The adjustment procedures differ slightly between the two brands.

To Adjust a “Len Gordon” Switch:

1. Facing the switch, you will notice a black, rectangular plastic tab, located on the forward-facing side of the switch (reference P-2). The black rectangle is a wheel lock tab; slide the tab fully left to unlock the adjustment wheel.
2. With water pump operating, and electrical power supplied to the heater, slowly rotate the top of the adjustment wheel TOWARDS you until the flow light (just) illuminates (the heater may start simultaneously, depending on the state of the control circuit time delay).
3. Slide the wheel locking tab fully back to the right-hand, locked position.

To Adjust a “TecMark” Switch:

1. (Reference photo P-3.) TecMark switches do not have an adjustment wheel lock.
2. With water pump operating, and electrical power supplied to the heater, slowly rotate the top of the adjustment wheel AWAY from you, until the flow light (just) illuminates (the heater may start simultaneously, depending on the state of the control circuit time delay).

To Complete the Adjustment Procedure— Either Brand Switch:

1. With electrical power remaining ON to the heater, shut off the power to the circulating pump. If the switch has been correctly adjusted, when the water pump stops, the flow light will go dim and, if the heater was operating (operation dependant on the state of control circuit time delay), the heater should shut off. **CAUTION:** If flow light remains illuminated and/or the heater continues to operate with water pump off, readjust water pressure switch to **ensure heater will not run without water flow.**
2. Reinstall heater front cover.

Should adjustment of the water pressure switch prove unsuccessful, contact AquaCal technical support (800-786-7751); site-specific factors may require the installation of an external flow switch.

Water Pressure Switch Adjustment (continued)

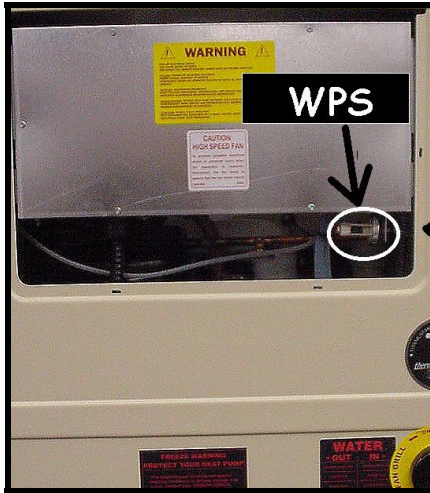

P-1, WPS Location

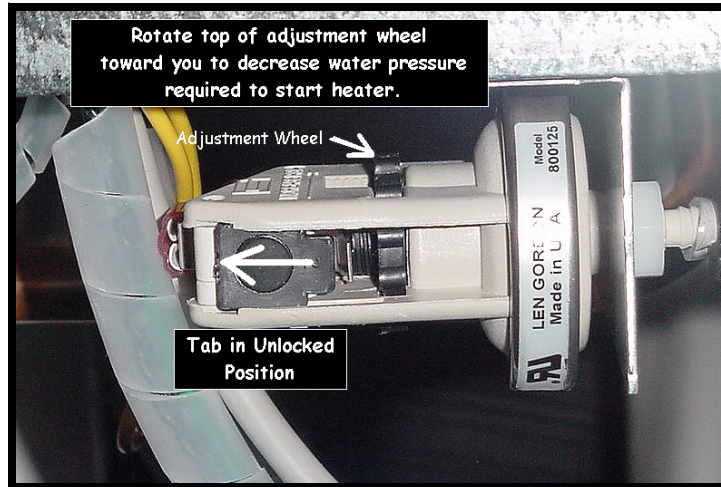

P-2, Len Gordon Style Switch

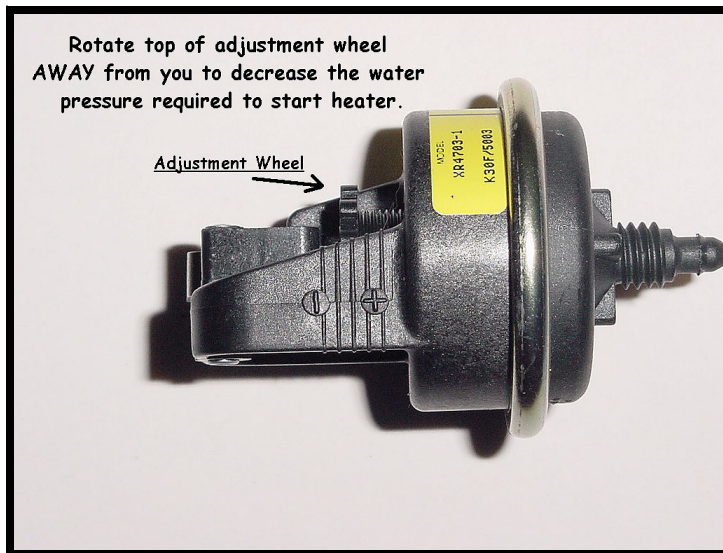

P-3, TecMark Style Switch

Defrost System: Description and Troubleshooting

Overview

Heat wave and AeroTemp *Icebreaker* models incorporate an active, time and temperature, hot-gas defrost system. Basically stated, when an evaporator coil thermostat senses a significant icing condition, the control circuit reverses the flow of refrigerant, sending hot refrigerant vapor to the outdoor coil. The effect is a rapid melting of ice and frost, and a quick return to the normal heating mode.

Major Components

- ◆ Defrost Controller: Monitors condition (open or closed) of binary outdoor coil defrost temperature sensor (DTS). The controller accumulates compressor run time where conditions are conducive to ice formation. Upon an accumulation of a predetermined period of “ice forming” run time, controller initiates a defrost cycle by supplying control voltage through the DTS, energizing the coil of control relay #1 (CR-1); in turn, CR-1 energizes the refrigerant circuit reversing valve (and stops fan operation), sending hot refrigerant vapor to the outdoor coil. (When the DTS warms, the DTS contacts open, de-energizing the refrigerant reversing valve and—if a call for heat is present—re-starting the fan motor.)
- ◆ Defrost Temperature Sensor (DTS): Normally-open SPST switch that attaches to a return loop of the evaporator (outdoor) refrigerant coil. The DTS senses evaporator coil temperature, and sensor contacts close on a fall in temperature. Specifications: Close @ 25°F, Open @ 55°F (+- 9°F).
- ◆ Control Relay #1 (CR-1): 3-pole, double-throw relay, equipped with a 24-volt control coil. Upon an accumulation of sufficient “icing run time” this relay receives a 24-volt signal from the defrost controller, through the DTS. When CR-1’s coil is energized, the refrigerant reversing valve is energized; the fan relay is de-energized; the defrost light is illuminated, and the defrost controller reset circuit (RST) is opened.
- ◆ Fan Relay: DPDT relay, used in a SPST capacity; relay is equipped with a 24-volt control coil. During normal heating (non-defrost) operation, the control coil is energized and electrical power for the fan motor is provided through the closed terminals of this relay. Upon a call for defrost, CR-1 interrupts control voltage to the fan relay. With Fan relay “open”, fan operation ceases.
- ◆ Refrigerant Reversing Valve (RRV): Mechanical, 24-volt, pilot operated electric solenoid valve. During heating mode, the RRV control coil is de-energized. Upon a call for defrost, the RRV control coil is energized through CR-1. Now energized, the RRV diverts hot refrigerant vapor to the outdoor refrigerant air coil, and defrost is accomplished.

Sequence of Operation

1. Start... Normal Heating Cycle in Operation: evaporator temperature above 25°F;
2. Evaporator temperature falls to 25°F; DTS closes, and the defrost controller begins accumulating “ice forming” run time. Run time accumulates only when the compressor is operating.
3. With DTS remaining closed, and when sufficient “ice forming” run time has accumulated (50-Minutes for Heat Wave and AeroTemp models), the defrost controller initiates a defrost cycle.
4. The heater will remain in defrost until the DTS opens; except, if, after 10-minutes, the DTS has not opened, the defrost controller will terminate the defrost cycle.
5. If defrost was terminated by the defrost controller, with DTS still closed, the defrost controller will immediately begin accumulating “ice forming” run time. Otherwise, “ice forming” run time will not begin accumulating until such a time that the DTS re-closes.

Troubleshooting Defrost System

WARNING!

Failure to heed the following may result in permanent injury or death.

Heat pumps contain no owner-repairable components. Repairs must not be attempted by untrained and/or unqualified individuals. If service is deemed necessary, contact installing dealer or AquaCal Customer Support at: (800) 786-7751. The following defrost system troubleshooting procedures to be performed by authorized service personnel only.

Testing Operation of Defrost Controller:

1. Disconnect power to heater and place a jumper across the electrical connections of the DTS.
2. With HEAT mode selected, restore power to heater and turn selected thermostat to highest setting (heater should restart following five (5) minute time delay).
3. Using a suitable screwdriver or additional test jumpers, short across the two “test” pins located on the defrost control board. Shorting between the test pin terminals speeds up the “ice forming” run time by a factor of 256. In other words, if the defrost controller has been time-set for a 50-minute “ice forming” run time– with the test pins remaining shorted, the heater should go into defrost in approximately 20-seconds.
4. If defrost does not initiate using this test method, the defrost controller is suspect. However, before condemning the controller, with test underway, measure voltage across CR-1 control coil; if 24-volts can be measured there, the inability to initiate defrost likely lies with CR-1, the RRV, or associated wiring. Troubleshoot those components as you would any other electromechanical device.

Testing Operation of Defrost Temperature Sensor :

The Following Procedure to be Performed by Qualified HVAC Service Personnel Only

(Best Performed After Verifying Remaining Portions of Defrost System Are Functional)

1. Disconnect power to heater; remove black fan motor power wire from the fan relay terminal. Electrically isolate the removed wire and female connector using a wrap of electrical tape.
2. Attach refrigerant service manifold gages to refrigerant test ports. Attach a reliable, surface-reading thermometer to the suction line (clamp-on thermocouple-type recommended). Position the thermometer probe as close as possible to the evaporator outlet..
3. Repeat analysis procedure per Testing Operation of Defrost Controller, except do **NOT** “...place a jumper across the DTS terminals.”
4. Start heater. After a period of a few minutes, because the fan is not operating, evaporator temperature should fall to a point where the DTS closes and defrost initiates.
5. To prevent compressor damage as test progresses, monitor the suction tube temperature and superheat developed; terminate test if superheat approaches “0”. The suction tube temperature should also be used as a relative guide as to the temperature seen by the DTS.
6. If DTS does not close and initiate a defrost cycle, repeat test substituting a known-to-be-seviceable DTS.
7. In some instances, moving the DTS to a new coil position–closer to where ice is forming–will solve defrost initiation issues.
8. Restore fan circuit wiring to normal configuration.

Troubleshooting Refrigerant Circuit Problems

NOTICE: Refrigerant Circuit Service by EPA Certified Individuals Only

WARNING !

Failure to heed the following may result in permanent injury or death.

Heater contains refrigerant under high pressure. Repairs to the refrigerant circuit must not be attempted by untrained and/or unqualified individuals. Service must be performed only by qualified HVAC technicians. Recover Refrigerant to relieve pressure before opening system.

Possible Abnormal Conditions & Related Symptoms

(Refer to Performance Charts following this section)

Unit Overcharged:

- Head pressure will be above normal;
- Suction pressure will be normal or slightly high (high, only if grossly overcharged);
- Unit amperage will be somewhat high;
- Liquid subcooling will be higher than normal;
- Superheat will be normal to low (low, only if grossly overcharged).

Explanation: Excess liquid refrigerant backs up in the condenser (into discharge line if grossly overcharged). Elevated head pressure & high liquid subcooling, with near-normal suction pressure and superheat, will be present. Unless grossly overcharged, the TXV will hold back the overcharge, maintaining near normal suction pressure and superheat.

Unit Undercharged:

- Head pressure will be below normal;
- Suction pressure will be slightly low, to very low (depending on degree of undercharge);
- Amperage will be low;
- Liquid subcooling will be very low or nonexistent;
- Superheat will be higher than normal.

Explanation: A full column of liquid may not be consistently present at the TXV inlet. This condition results in low suction pressure with higher than normal superheat. The liquid subcooling will be low, as will be the head pressure.

TXV Stuck Closed:

- Head pressure will be excessive;
- Suction pressure will be lower than normal;
- Amperage will be high;
- Liquid subcooling will be higher than normal;
- Superheat will be higher than normal;
- Distributor lines *may* be frosted, iced, or very cold to touch.

Explanation: The flow of refrigerant is (mostly) stopped at the TXV. This results in a low suction reading with high superheat. As liquid refrigerant “backs up” in the condenser, there is less room for high-pressure vapor coming from the compressor. Therefore, head pressure increases above normal (Heat Wave and AeroTemp models do not have sufficient space on the high-side to store the entire charge). With little refrigerant flowing, more heat is being removed in the condenser than is being added at the evaporator— result: higher than normal liquid subcooling.

Troubleshooting Refrigerant Circuit Problems (Continued)

TXV Stuck Open:

- Head pressure will be slightly to moderately low;
- Suction pressure will be slightly high to very high;
- Amperage (not a reliable indicator of this condition);
- Liquid subcooling will be lower than normal;
- Superheat will be minimal or nonexistent;
- Suction line, and possibly a large portion of compressor, will be very cold and possibly “sweating”.

Explanation: Refrigerant is flowing through the system too quickly; enough heat cannot be added in the evaporator to boil off all the liquid refrigerant. The main effect is to flood the suction line and compressor with liquid refrigerant. The primary indicator of this condition is little or no suction line superheat. Also, as the TXV is not holding back the required amount of refrigerant, there may be flash gas (high-pressure vapor) present in the liquid line; this is indicated by reduced liquid subcooling.

Insufficient Condenser Water Flow:

- Head pressure will be moderately high to very high;
- Suction pressure may be normal to slightly high;
- Amperage will be higher than normal;
- Liquid subcooling will be absent; the liquid line will be very warm or even hot to touch. When combined with high condenser water ΔT (see next bullet item), this condition is a prime indicator of insufficient condenser water flow;
- Condenser entering-leaving water temperature difference (water ΔT) will be higher than normal... This condition, is a prime indicator of insufficient condenser water flow;
- Superheat will be high-normal to high.

Explanation: Heat is not being removed in the condenser in quantities sufficient to produce appreciable amounts of liquid refrigerant. With no liquid seal occurring in the condenser, the liquid line—in essence—becomes an extended discharge line. Keys to diagnosis: very warm to hot liquid line, and a high condenser water ΔT .

Refrigerant Circuit Performance Charts

Use of Charts- Information for the Technician:

The charts are intended for use by trained and qualified air-conditioning and refrigeration technicians only. The charts are compiled specifically for evaluation and diagnostic purposes, and are NOT designed for use as charging charts. To apply the chart data to actual conditions: gather the operating pressures, suction tube superheat & liquid line subcooling values, water temperature change through the heater, and the total unit amps. Locate a chart that most closely represents current actual ambient conditions. Readings obtained that differ from the charts in excess of 10% (+ or -), may indicate a problem within the mechanical refrigeration system. For guidance in diagnosing abnormal operating conditions, reference: Troubleshooting Refrigerant Circuit Problems, located in this manual just forward of this section. Some interpolation between charts will be necessary, should actual ambient conditions not align reasonably well with the charts. If refrigerant circuit readings appear normal, but *not* the Water ΔT value, the likely cause will be water flow above or below 45-GPM. (All Heat Wave and AeroTemp model refrigerant circuits will perform acceptably with condenser water flow between 20-to-70 GPM.)

Refrigerant Circuit Performance Charts (continued)

Refrigerant Circuit Performance Charts: A & B Voltage Models

Spa Condition: Water @ 104°F & 45 GPM, Ent. Air: 80 °F - 63% R.H.							
Model	Discharge Pressure PSIG	Suction Pressure PSIG	Superheat °F	Subcooling °F	Water ΔT °F	Nominal Unit Amps by Voltage Code	
						A	B
H/AT100"X"R	307	85	10	25	3.9	28	(Pending)
H/AT120"X"R	(Data Pending)						
Standard Condition: Water @ 80°F & 45 GPM, Ent. Air: 80 °F - 63% R.H.							
Model	Discharge Pressure PSIG	Suction Pressure PSIG	Superheat °F	Subcooling °F	Water ΔT °F	Nominal Unit Amps by Voltage Code	
						A	B
H/AT100"X"R	224	81	11	20	4.0	23	(Pending)
H/AT120"X"R	205	74	16	18	4.6	25	
Low Condition: Water @ 80°F & 45 GPM, Ent. Air: 50 °F - 63% R.H.							
Model	Discharge Pressure PSIG	Suction Pressure PSIG	Superheat °F	Subcooling °F	Water ΔT °F	Nominal Unit Amps by Voltage Code	
						A	B
H/AT100"X"R	218	49	8	31	2.8	22	(Pending)
H/AT120"X"R	212	44	9	26	3	24	
High R.H. Condition: Water @ 80°F & 45 GPM, Ent. Air: 80 °F - 80% R.H.							
Model	Discharge Pressure PSIG	Suction Pressure PSIG	Superheat °F	Subcooling °F	Water ΔT °F	Nominal Unit Amps by Voltage Code	
						A	B
H/AT100"X"R	227	89	14	18	4.4	23	(Pending)
H/AT120"X"R	208	80	17	19	4.9	26	
Cooling Condition: Water @ 85°F & 45 GPM, Ent. Air: 95 °F - 34% R.H.							
Model	Discharge Pressure PSIG	Suction Pressure PSIG	Superheat °F	Subcooling °F	Water ΔT °F	Nominal Unit Amps by Voltage Code	
						A	B
H/AT100"X"R	276	93	14	1	2.5	27	(Pending)
H/AT120"X"R	280	82	16	6	3	32	

Refrigerant Circuit Performance Charts (continued)

Refrigerant Circuit Performance Charts: D & H Voltage Models

Spa Condition: Water @ 104°F & 45 GPM, Ent. Air: 80 °F - 63% R.H.							
Model	Discharge Pressure PSIG	Suction Pressure PSIG	Superheat °F	Subcooling g °F	Water ΔT °F	Nominal Unit Amps by Voltage Code	
						D	H
H/AT100"X"R	(Data Pending)					(Pending)	(Pending)
H/AT120"X"R							
Standard Condition: Water @ 80°F & 45 GPM, Ent. Air: 80 °F - 63% R.H.							
Model	Discharge Pressure PSIG	Suction Pressure PSIG	Superheat °F	Subcooling g °F	Water ΔT °F	Nominal Unit Amps by Voltage Code	
						D	H
H/AT100"X"R	(Data Pending)					(Pending)	(Pending)
H/AT120"X"R							
Low Condition: Water @ 80°F & 45 GPM, Ent. Air: 50 °F - 63% R.H.							
Model	Discharge Pressure PSIG	Suction Pressure PSIG	Superheat °F	Subcooling g °F	Water ΔT °F	Nominal Unit Amps by Voltage Code	
						D	H
H/AT100"X"R	(Data Pending)					(Pending)	(Pending)
H/AT120"X"R							
High R.H. Condition: Water @ 80°F & 45 GPM, Ent. Air: 80 °F - 80% R.H.							
Model	Discharge Pressure PSIG	Suction Pressure PSIG	Superheat °F	Subcooling g °F	Water ΔT °F	Nominal Unit Amps by Voltage Code	
						D	H
H/AT100"X"R	(Data Pending)					(Pending)	(Pending)
H/AT120"X"R							
Cooling Condition: Water @ 85°F & 45 GPM, Ent. Air: 95 °F - 34% R.H.							
Model	Discharge Pressure PSIG	Suction Pressure PSIG	Superheat °F	Subcooling g °F	Water ΔT °F	Nominal Unit Amps by Voltage Code	
						D	H
H/AT100"X"R	(Data Pending)					(Pending)	(Pending)
H/AT120"X"R							

REPLACEMENT PARTS

H/AT100-120"X"R

PART DESC.	H100AR	H100BR	H100DR	H100HR	H120AR	H120BR	H120DR	H120HR
WAT. IN MANI.	PLA0203	PLA0203	PLA0203	PLA0203	PLA0201	PLA0201	PLA0201	PLA0201
WAT. OUT MANI.	PLA0202	PLA0202	PLA0202	PLA0202	PLA0200	PLA0200	PLA0200	PLA0200
CONDENSER	TI5555S01D	TI5555S01D	TI5555S01D	TI5555S01D	TI6565S01D	TI6565S01D	TI6565S01D	TI6565S01D
COMPRESSOR	H22R583ABC	H20R583DBY	H70R583DBE	H70R583ABK	H20R723ABC	H20R723DBY	ZR68KCE-TFD	ZR68KCE-PFJ
BASE	PCP0015	PCP0015	PCP0015	PCP0015	PCP0015	PCP0015	PCP0015	PCP0015
EVAPORATOR	ACP0005	ACP0005	ACP0005	ACP0005	ACP0005	ACP0005	ACP0005	ACP0005
SUCTION LINE	CPA0215	CPA0215	CPA0215	CPA0215	CPA0205	CPA0205	CPA0209	CPA0209
LOW PRESS. SW.	6037	6037	6037	6037	6037	6037	6037	6037
DISCHARGE LINE	CPA0213	CPA0213	CPA0213	CPA0213	CPA0206	CPA0206	CPA0210	CPA0210
HIGH PRESS. SW.	6087	6087	6087	6087	6087	6087	6087	6087
LIQUID LINE	CPA0216	CPA0216	CPA0216	CPA0216	CPA0208	CPA0208	CPA0208	CPA0208
EXPANSION VALVE	REP0001	REP0001	REP0001	REP0001	REP0001	REP0001	REP0001	REP0001
RECEIVER	2016	2016	2016	2016	2016	2016	2016	2016
ACCUMULATOR	1059	1059	1059	1059	1059	1059	1059	1059
REVERSING VALVE	1090	1090	1090	1090	1090	1090	1090	1090
DEFROST SWITCH	6600	6600	6600	6600	6600	6600	6600	6600
CON. PNL PLASTIC	PCP0010	PCP0010	PCP0010	PCP0010	PCP0010	PCP0010	PCP0010	PCP0010
CON. PNL LABEL	LBP0008	LBP0008	LBP0008	LBP0008	LBP0008	LBP0008	LBP0008	LBP0008
POTENTIOM KNOBS	6113	6113	6113	6113	6113	6113	6113	6113
AMBER LIGHTS	6281	6281	6281	6281	6281	6281	6281	6281
SWI, SPDT	6027	6027	6027	6027	6027	6027	6027	6027
SWI, DPDT	6026	6026	6026	6026	6026	6026	6026	6026
POTENTIOMETER	6105B	6105B	6105B	6105B	6105B	6105B	6105B	6105B
TRANSFORMER	6209	6209	6807	6209	6209	6209	6807	6209
PH. ROT. MONITOR	N/A	6035	6035	N/A	N/A	6035	6035	N/A
DOOR SWITCH	N/A	N/A	6801	6801	N/A	N/A	6801	6801
RUN CAPACITOR	ECP0003	ECP0003	ECP0003	ECP0003	60010	60010	ECP0004	ECP0003
CONTACTOR	6061	6147	6147	6061	6061	6147	6147	6061
FAN RELAY	ECP0001	ECP0001	ECP0001	ECP0001	ECP0001	ECP0001	ECP0001	ECP0001
WAT. PRESS SWI.	6248	6248	6248	6248	6248	6248	6248	6248
CPI DEFROST BRD	6169	6169	6169	6169	6169	6169	6169	6169
HW STAT BRD	6270	6270	6270	6270	6270	6270	6270	6270
CONTROL RELAY	6196	6196	6196	6196	6196	6196	6196	6196
TIME DELAY	6102A	6102A	6102A	6102A	6102A	6102A	6102A	6102A
10- POS. TERM. LUG	6318	6318	6318	6318	6318	6318	6318	6318
5- POS. OPTION BLK	6320	6320	6320	6320	6320	6320	6320	6320
FAN BLADE	3104	3104	3104	3104	3104	3104	3104	3104
FAN MOTOR	3114	3114	3103	3114	3114	3114	3103	3114
FAN TOP PLASTIC	7055	7055	7055	7055	7055	7055	7055	7055
FAN GRILLE	71019	71019	71019	71019	71019	71019	71019	71019
LOGO DISK	5319	5319	5319	5319	5319	5319	5319	5319
CON. PANEL ASSY.	ECA0209	ECA0209	ECA0209	ECA0209	ECA0209	ECA0209	ECA0209	ECA0209
ACCESS PANEL	HPA0216	HPA0216	HPA0217	HPA0217	HPA0216	HPA0216	HPA0217	HPA0217
FRONT PANEL	HPA0218	HPA0218	HPA0218	HPA0218	HPA0218	HPA0218	HPA0218	HPA0218
ELEC. ENC. COVER	HPA0214	HPA0214	HPA0215	HPA0215	HPA0214	HPA0214	HPA0215	HPA0215

Effective 01/20/2004

To order replacement parts, contact AquaCal Customer Support: (800) 786-7751

CONTACTING THE FACTORY

What We Need to Know When You Call Us

If you should need to call AquaCal for service, please have the following information ready:

Model: _____

Serial Number: _____

Installation Date: _____

Having the above information ready will speed up the service process and allow us to respond more quickly. A brief but concise description of what the unit is, or is not doing, will also help us to help you.

Please call up toll-free at: (800) 786-7751. We are here to serve you from 8 A.M. to 5 P.M. EST, Monday through Friday. If calling after hours, our voice mail system will handle your call. Be sure to leave your name, complete address, and telephone number.

If you prefer, you may FAX the information to: (727) 821-7471.

Thank You !





SWIMMING POOL HEAT PUMPS

2737 24th St. North
St. Petersburg, FL 33713
1-800-786-7751