



AUTOPILOT
SALT CHLORINE GENERATORS

Heat Pump

Quick Start Guide

Models: 035, 055, 075, 115, 110, 120, 121, 155, 156, & 175



For product manuals and further installation / operation procedures
visit www.AquaCal.com

Important
Read This Guide Before Installing or Operating Heat Pump

SECTION 1 - GENERAL INFORMATION

CONTACTING AQUACAL AUTOPILOT

Web	www.AquaCal.com
Phone	(727) 823-5642 8:00 a.m. to 5:00 p.m. Eastern time, Monday through Friday
Fax	(727) 821-7471

Please have your model and serial numbers available when contacting AquaCal AutoPilot for questions, service, or parts.

SAFETY

For personal safety, and to avoid damage to equipment, follow all safety instructions displayed in this guide. Repair and service of your heat pump must be performed by qualified service personnel. Failure to properly install, operate, maintain, or repair the heat pump will void factory warranty. Please note "WARNING" signals relate to personal safety, while "CAUTION" signals promote avoiding damage to equipment.

Follow all National Electric Codes (NEC) unless State or Local guidelines supersede. When installing and using your heat pump, basic safety precautions must always be followed, including the following:

 **WARNING** - Failure to heed the following may result in injury or death.

- Heat pumps contain no owner-repairable components.
- Electrical Installation should be by Licensed Electrician only.
- Service to the refrigerant circuit must be performed only by qualified HVAC Technicians.
- Heat pumps utilize high voltage and rotating equipment. Use caution when servicing.
- Heater contains refrigerant under pressure. Recover refrigerant before opening system.
- Prolonged immersion in water warmer than normal body temperature can cause fatal Hyperthermia. The use of alcohol, drugs, or medication can greatly increase the risk of fatal Hyperthermia.
- Persons having an adverse medical history, or pregnant women, should consult a physician before using a hot tub or spa. In addition, children and the extreme elderly should be supervised by a responsible adult.

 **CAUTION** - Failure to heed the following may result in equipment damage.

- Improper water chemistry can cause damage to pump, filter, pool shell, etc. To avoid equipment damage, maintain Pool/Spa water per standards detailed later in this manual.
- Water flow exceeding max flow requires a bypass. Damage due to excessive water flow will void warranty.

SAVE THESE INSTRUCTIONS

SPECIFICATIONS

Specification	Description
Electrical Service	See data plate attached to front cover or behind front access panel on equipment.
Water Flow Requirements	30 - 55 gallons per minute (gpm) ideal range. A heater bypass is required for water flow greater than 70 GPM flow. Exception: 035, 055, and 075 with a revision letter of B or higher have a 20-45 GPM range, with a max of 45 GPM.

Table 1

STANDARDS

Standards*	Title
Article 440	Standard for Safety for Electric Spas, Equipment Assemblies, and Associated Equipment.
Article 680	Standard for Safety for Swimming Pool Pumps, Filters and Chlorinators.
IEC 60335-1-2001	Household and similar electrical appliances - Safety - General requirements
IEC 60335-2-40 2006	Household and similar electrical appliances - Safety – Particular requirements for electrical heat pumps, air-conditioners and dehumidifiers.
NFPA 70	The electrical installation must conform to the current version of the NEC, and all applicable local and state codes.
UL1995	Heating and cooling equipment.

* Not all standards are applicable in all installations. Follow all local applicable codes.

Table 2

SECTION 2 - INSTALLATION

For commercial or complete installation instructions please, visit www.AquaCal.com for equipment manual.

EQUIPMENT CLEARANCES

Keep the area immediately adjacent to the heat pump clear of items such as shrubs and bushes, lawn furniture, chemicals containers, etc. These items can prevent air from circulating properly through the heater, and will result in inefficient operation and/or damage to the heat pump.

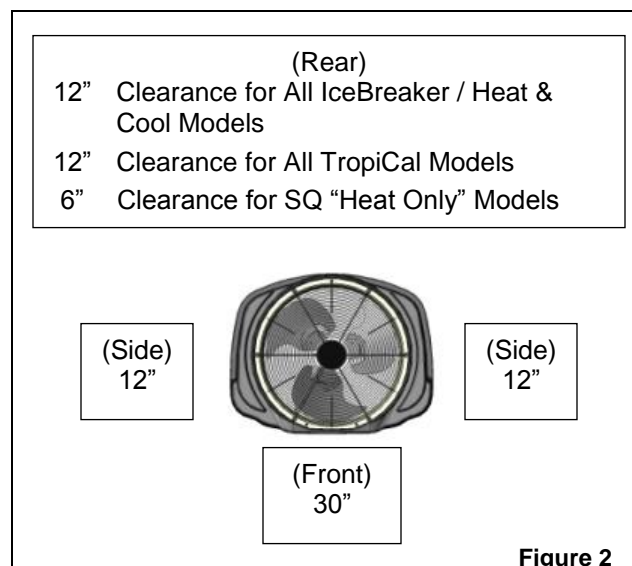
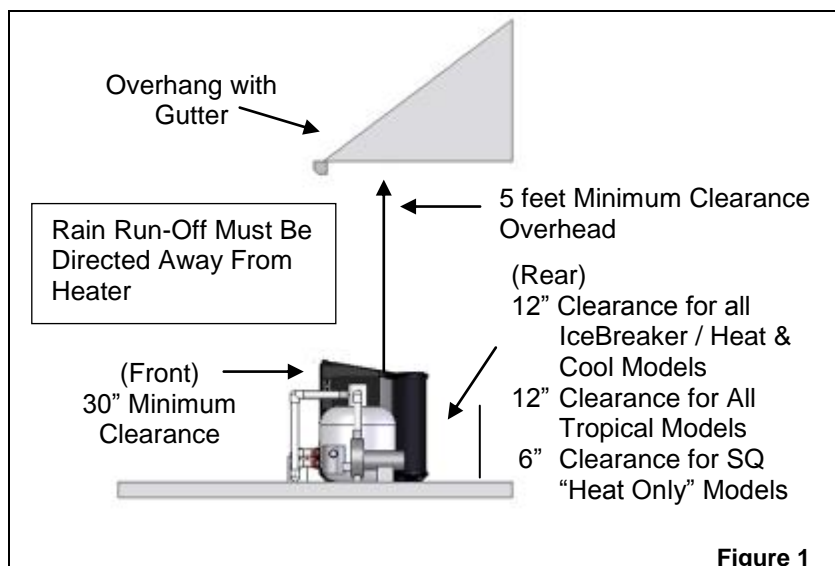

PLUMBING SCHEMATIC

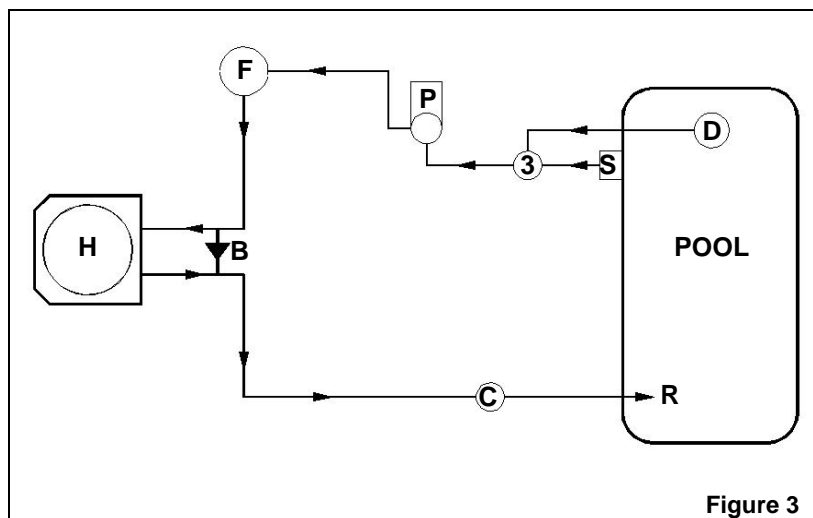

- 3 = Three-Way Valve
- B = Bypass Check Valve (5lb) for Water Flow Over Max Flow (see Specifications for details)
- C = Chlorinator
- D = Main Drain
- F = Filter
- H = Heat Pump
- P = Water Pump
- R = Return
- S = Skimmer

ELECTRICAL REQUIREMENTS

- 1) Locate the equipment power disconnect within 6-feet of the heater's electrical enclosure.
- 2) Never mount power disconnects directly to heat pump.
- 3) Only use copper conductors.
- 4) Use sequencing controllers when multiple heaters are installed on site.
- 5) Local codes and regulations may require the use of a ground fault interruption device (GFI Circuit Breaker). Nuisance tripping of these devices is common and not covered under the terms of the Manufacturer's warranty.
- 6) Review online product manual when connecting external controller devices to heat pump.

SECTION 3 - OPERATION

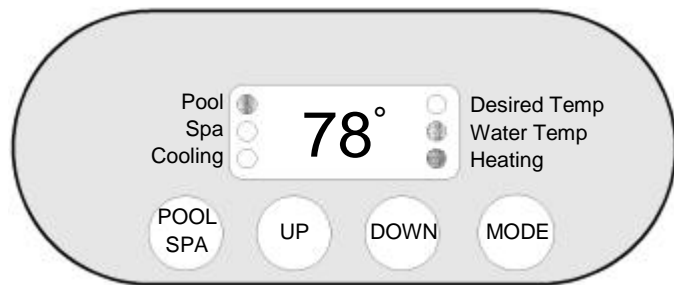

Figure 4

INDICATOR LIGHTS

LIGHTS	EXPLANATION	SUPPLEMENTAL INFORMATION
"Pool"	Pool Thermostat Selected	
"Spa"	Spa Thermostat Selected	
"Cooling"	Actively Cooling Water	Not applicable for Straight Heat models.
"Desired Temp"	Setting Desired Water Temperature	
"Water Temp"	Actual Water Temperature	
"Heating"	Actively Heating Water	

Table 3

BUTTONS

BUTTONS	EXPLANATION	SUPPLEMENTAL INFORMATION
"Pool / Spa"	Select between Pool and Spa	Please note – this does not turn off equipment. It only allows a user to toggle between the Pool thermostat and the Spa thermostat.
"Up"	Select to raise temperature set point or move up in a menu choice	
"Down"	Select to lower temperature set point or move down in a menu choice	
"Mode"	Select a mode	Modes available are "ACH", "COOL", "HEAT", and "OFF". Please note – "ACH" and "COOL" only available on some models.

Table 4

DISPLAY

MESSAGE	EXPLANATION	SUPPLEMENTAL INFORMATION
"000"	A user lockout code has been activated.	A numeric code is required before any temperature adjustment can be entered. Use the "UP" or "DOWN" arrow to enter code, then select "MODE" to temporarily unlock Heat Pump. If code is unknown, a re-set option is available in product manual. Manuals can be downloaded from www.AquaCal.com .
"ACH"	Auto-Change Over Mode	When this mode is active, the heat pump will automatically switch between heating and cooling modes to maintain a set temperature point within ± 3 degrees. Feature available for Heat & Cool units.
"COOL"	Cooling Mode	Heat Pump is set to cool the water. Feature available for Heat & Cool units.
"HEAT"	Heating Mode	Heat Pump is set to heat water.
"OFF"	Unit off	Heat Pump can be turned off by using "MODE" button or setting temperature below 45 degrees. Heat Pump will not allow a set temperature to be programmed until turned on again.
"xx°"	Current Water Temperature (Example 78°)	Temperature can be set from 45° F to 104° F. This can be displayed in Fahrenheit or Celsius depending on programming.
FLO	No water flow through Heat Pump	This can be a normal display depending on system settings. See "Troubleshooting" if needed.

Table 5

PROGRAMMING

Activity	Steps
Adjusting Temperature	Step 1: Select the "POOL / SPA" button to choose the thermostat to adjust. Step 2: Select the "UP" or "DOWN" button to increase or decrease the desired set temperature. Step 3: Once set, the current water temperature will be displayed. The Heat Pump will start to operate to meet the desired temperature. Please note a time delay will be experienced if Heat Pump has just been initialized. This delay is between 4 to 5 minutes.
Turning Heat Pump "ON"	Step 1: Confirm Heat Pump has power. Step 2: Select the "MODE" button. Step 2: Using the "UP" or "DOWN" arrow, select "ACH", "COOL", "HEAT", or "OFF". See section on Display for "MODE" usage.
Turning Heat Pump "OFF"	Step 1: Select the "MODE" button. Step 2: Using the "UP" or "DOWN" arrow, select "OFF" Please note – setting temperature below 45° F will also turn off Heat Pump.
Setting to "Celsius" or "Fahrenheit"	Step 1: Select and hold down both the "UP" and "DOWN" arrow keys simultaneously until the Celsius / Fahrenheit code (CF1) appears on the display. Step 2: Select the "UP" or "DOWN" arrow to select "1" for Fahrenheit or "2" for Celsius. Step 3: Allow display to time-out.
Switching from Pool to Spa	Select the "POOL / SPA" button.

Table 6

SECTION 4 - MAINTENANCE

POOL CHEMISTRY

Maintain pool water with the following chemical levels. Commercial applications may vary from depending on locale. All values show in PPM (Parts Per Million).

Chemical	Pool	Spa
Chlorine	1 to 3 parts per million (PPM)	1.5 to 3 PPM
Bromine	1 to 3 PPM	3 to 5 PPM
pH	7.4 to 7.8 PPM	7.2 to 7.8 PPM
Total Alkalinity	80 to 140 PPM	80 to 120 PPM
Calcium Hardness	200 to 400 PPM	200 to 400 PPM
Total Dissolved Solids	1,000 to 2,000 PPM	1,500 to 2,000 PPM

Table 7

WINTERIZING

In areas where freezing conditions are a rare occurrence, allow the filtration system to run continuously throughout the freeze period. Typically, during light freeze conditions, circulating (moving) water will not freeze. In areas where freezing conditions are prevalent and sustained, the heat pump must be winterized as follows:

- 1) Disconnect all electrical power to the heater; turn off circulating pump.
- 2) At the two (2) connection unions, disconnect the plumbing to the heater (removal is counter-clockwise).
- 3) If your unit has an external drain plug, remove plug. This plug would be located at lower, front corner of heater (position may vary between models). Allow water to drain out of the condenser. Replace the winterizing plug by threading the plug in clockwise until just snug, then apply an additional 1/8 turn.
- 4) If no drain plug is found, unit is self draining from unions. Check online manuals for appropriate winterizing procedures on heat pumps older than 2005.
- 5) To prevent insects and vermin from entering the plumbing during the winterized period, partially reconnect the two (2) plumbing connection unions: couple each union one or two threads; this will permit condensation to drain, but will prevent most insects and animals from entering the plumbing circuit.

START UP

To ready a winterized heat pump for use, simply retighten plumbing connection unions. Hand-tight is generally sufficient.

SECTION 5 - TROUBLESHOOTING**ERROR CODES**

SYMPTOM	RULE OUT	RESOLUTION
"FLO"		
Insufficient water flow through heater or circulation pump is off	Insufficient Water Flow	Step 1: Confirm water pump is on and water valves are in the correct position to allow water to flow through Heat Pump. If error persists, proceed to next step.
	Filtration Dirty	Step 2: Confirm filtration system is clean. Backwash if needed. If error persists, proceed to next step.
	Possible Water Pressure Switch	Step 3: Request Service
"CEr" Error		
Communication Fault	N/A	Request Service
"CSE" Error		
Control System Error	N/A	Request Service
"dPC" Error		
Defrost Sensor Shorted	N/A	Request Service
"dPO" Error		
Defrost Sensor Open	N/A	Request Service
"FS" Error		
Unit in defrost mode.	Normal defrost mode	Step 1: If error persists after air temperature is over 50° F, request service.
"HP" Error		
High Pressure.	Insufficient Water Flow	Step 1: Confirm water pump is on and water valves are in the correct position to allow water to flow through Heat Pump. If error persists, proceed to next step.
	Filtration Dirty	Step 2: Confirm filtration system is clean. Backwash if needed. If error persists, proceed to next step.
	Possible Refrigerant Issue	Step 3: Request Service
"HP5" Error		
Equipment has registered high pressure five times and locked.	Insufficient Water Flow and/or Filtration Dirty	Step 1: Follow steps outlined in "HP" error, then reset circuit breaker to clear error. If error persists, request service.
"LP" Error		
Refrigerant Issue	N/A	Request Service
"LP5" Error		
Refrigerant Issue	N/A	Request Service
"OTA"		
Over Temperature Alarm Temperature over 110° F (Unit Locked)	Other heating equipment	Check if alternate heater (such as a solar heater) is heating water leading to heat pump. If "yes", turn off alternate heater and check if error clears. If error persists, request service.
"PC" Error		
Water Temperature Sensor Shorted	N/A	Request Service
"PO" Error		
Water Temperature Sensor Open	N/A	Request Service

Table 8