

AquaCal AutoPilot Great Big Bopper Operation and Installation Manual



TABLE OF CONTENTS

SECTION 1 - GENERAL INFORMATION

1.1 Contacting AquaCal AutoPilot.....	1
1.2 Safety	1

SECTION 2 - OPERATION

2.1 Control Panel.....	3
2.1.a Indicator Lights	3
2.1.b Control Buttons	3
2.1.c LED Display	3
2.1.d User Level Programs	4
Turning Heat Pump On.....	4
Setting Operating Mode (“HEA”, “COO”, or “ACH”).....	4
Turning Heat Pump Off.....	4
Setting Thermostats.....	4
Selecting Celsius or Fahrenheit	4
Enabling Lockout Option.....	5
Unlocking Heat Pump	5
Disabling Lockout Option.....	5
2.2 Heating Water.....	6
2.3 Cooling Water.....	6
2.4 Heat Pump’s Defrost Operation	7

SECTION 3 - MAINTENANCE

3.1 Cleaning Equipment	9
3.2 Monitoring Conditions	10
3.2.a Pool Chemistry	10
3.2.b Clearances.....	10
3.2.c Water Flow.....	10
3.2.d Irrigation and Storm Run-Off	10
3.4 Winterizing.....	11
3.5 Preventive Maintenance	11

SECTION 4 - INSTALLATION

4.1 Equipment Specifications.....	13
4.1.a General.....	13
4.1.b Unit Dimensions.....	13
4.1.c Access Panels	14
4.2 Placing Heat Pump	14
4.2.a Indoor versus Outdoor Installation	14
4.2.b Positioning Clearances	14
4.2.c Controlling Irrigation and Rainwater Runoff	14
4.2.d Planning for Condensation.....	15
4.2.e Mounting Pad Requirements.....	15
4.2.f Anchoring Heat Pump to Pad.....	15
4.3 Plumbing	15
4.3.b Plumbing Diagrams.....	16

TABLE OF CONTENTS

4.3.c In-Line Chlorine Feeders.....	18
4.3.d Water Connections to Heat Pump.....	18
4.3.f Maintaining Ability to Winterize	19
4.3.g Water Flow Rates and Operating Pressures	19
4.3.h Water Flow (Pressure) Switch Adjustment	19
4.3.i Installations with In-floor Cleaning Systems	21
4.4 Wiring	21
4.4.a Standards	21
4.4.b General Requirements	21
4.4.c Grounding and Bonding	21
4.4.d Sizing the Electrical Service	21
4.4.e Ground-Fault Protection.....	22
4.4.f External Controls / Equipment.....	22
4.4.g Positioning Mode Jumper.....	23
4.5 Programming	24
4.5.a Program Displays.....	25
4.5.b Service Level Programs	25
Entering Service Menu	25
Deactivating Time Delay.....	25
Configuring for External Controller.....	25
Configuring for Remote Flow Switch.....	26
Calibrating Water Sensor.....	26
Calibrating Defrost Sensor.....	26
Adjusting Dead Band Differential	27
Re-Setting Heat Pump ("Back Door" Entry)	27
4.5.d Default Program Parameters	28
4.6 Optional Installation	28
4.6.a Pool and Spa Combination Heating	28
4.6.b Spa Heating Setback Option.....	28
SECTION 5 - TROUBLESHOOTING	
5.1 Symptom / Resolution Charts	29
Control Panel Not Working	29
Heat Pump Not Running.....	29
Heat Pump Running, Not Heating.....	30
Heat Pump Tripping Breaker	31
Heat Pump Won't Shut Off.....	31
Heat Pump Running, Not Cooling.....	31
Water Coming From Heat Pump.....	32
5.2 Fault Code Definitions	33
"dPO" Indicator	33
"PO" Indicator	33
"dPC" Indicator	33
"PC" Indicator	33
"HP" Indicator	33
"HP5" Indicator	33
"LP" Indicator	34

TABLE OF CONTENTS

“LP5” Indicator	34
“OtA” Indicator	34
“FLO” Indicator	34
“FS” Indicator.....	35
“CSE” Indicator.....	35
“CEr” Indicator	35
SECTION 6 - APPENDIX	
6.1 Available Accessories.....	37
6.2 Schematics.....	37
6.3 Connecting External Controllers	37

SECTION 1 - GENERAL INFORMATION

1.1 Contacting AquaCal AutoPilot

Web	www.AquaCal.com
Phone	(727) 823-5642 8-5 pm, Eastern M-F
Fax	(727) 821-7471

Please have your model and serial numbers available when contacting AquaCal AutoPilot for questions, service, or parts.

1.2 Safety

For personal safety, and to avoid damage to equipment, follow all safety instructions displayed on the equipment and within this manual. Repair and service of your heat pump must be performed by qualified service personnel. Should you suspect your equipment is not performing properly, refer to the section in this manual entitled: "Troubleshooting," to determine if a call for service is required. Warranties will be voided if the equipment has been improperly installed, maintained or serviced. Throughout this manual, safety signals have been placed where particular attention is required.

Safety Signals:

 **WARNING** - signal relates to personal safety.

 **CAUTION** - signal promotes avoiding damage to the equipment.

Follow all National Electric Codes (NEC) unless State or Local guidelines supersede. When installing and using your heat pump, basic safety precautions must always be followed, including the following:

-  **WARNING** - Failure to heed the following may result in injury or death.
- Repairs must be performed by a qualified technician. If service is deemed necessary, contact installing dealer or AquaCal AutoPilot Customer Support for a service center in your area.
 - Heat pump contains refrigerant under pressure. Repairs to the refrigerant circuit must not be attempted by untrained and/or unqualified individuals. Service must be performed only by qualified HVAC technicians. Recover refrigerant before opening system.
 - Improper water chemistry can present a serious health hazard. To avoid possible hazards, maintain pool / spa water per standards detailed later in this manual.

-  **CAUTION** - Failure to heed the following may result in equipment damage.
- Maintain proper water chemistry in order to avoid damage to pump, filter, pool shell, etc.
 - Do not use glue on the threaded portion of the equipment's unions. A glued-in-place union will prevent the equipment from being properly winterized.

SAVE THESE INSTRUCTIONS

SECTION 2 - OPERATION

2.1 Control Panel

The following information outlines how the control panel will operate for a standard installation. Control Buttons will operate differently for custom installations; such as a heat pump connected to an external controller. Please see appendix section entitled “Connecting External Controllers” for more information.

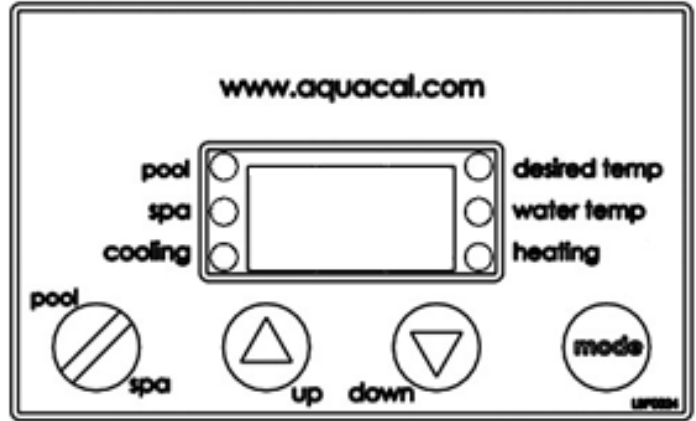

Figure 1

2.1.a Indicator Lights

“Pool”	Heat Pump is referencing the pool thermostat.
“Spa”	Heat Pump is referencing the spa thermostat.
“Cooling”	Indicates unit is cooling. Please note - both the compressor and the fan must be operating before this light will illuminate.
“Desired Temp”	Indicates temperature set point is displayed. This is displayed when “UP” or “DOWN” is selected.
“Water Temp”	Indicates current water temperature is displayed.
“Heating”	Indicates unit is heating. Please note - both the compressor and the fan must be operating before this light will illuminate.

Table 1

2.1.b Control Buttons

“Pool / Spa”	Select either the pool or the spa thermostat. (Inactive if unit under external control)
“Up”	Increase temperature set point.
“Down”	Decrease temperature set point.
“Mode”	Select heat pump operating mode.

Table 2

2.1.c LED Display

“XXX”	Heat Pump is on and displaying current water temperature.
“FLO”	No water flow is detected. Circulation pump is off or heat pump is not receiving correct water flow.
“OFF”	Heat pump has been turned off via the mode selector button or the temperature set point has been lowered below 45° F.
“FS”	Heat pump is in defrosting mode. See section entitled “Heat Pump’s Defrost Operation” on page 7 for more information.
“888”	Control program is initializing. Displays only as power is applied to the heat pump. The program version number will then be displayed.

Table 3

2.1.d User Level Programs

The heat pump allows for two levels of programming; User-level and Service-level programming. This section describes User-level programming.

STEPS	EXPLANATION
Turning Heat Pump On	
Turn power on at external fuse box or breaker disconnect.	<ul style="list-style-type: none"> • Controller performs a lamp test. The display reads "888". • Controller's software version is briefly displayed. • Controller displays as described in section entitled "LED Display" on page 3.
Setting Operating Mode ("HEA", "COO", or "ACH")	
Press "MODE" control button until "HEA" is selected.	Heat pump heats water to temperature set on thermostat.
Press "MODE" control button until "COO" is selected.	Heat pump cools water to temperature set on thermostat.
Press "MODE" button until "ACH" is selected.	Heat pump operates in either heating or cooling mode until reaching the temperature set on the thermostat. Once reached, the heat pump maintains the water temperature within four (4) degrees Fahrenheit of the temperature setting.
Turning Heat Pump Off	
Press "MODE" control button until "OFF" is selected.	<ul style="list-style-type: none"> • Heat pump functions, values, and programming become unavailable. The current water temperature is still displayed. • An alternate method of inactivating the heat pump is to lower the active thermostat below 45° F. This turns the thermostat off, leaving the heat pump itself available for programming.
Setting Thermostats	
Set heat pump to an active operating mode.	See "Setting Operating Mode ("HEA", "COO", or "ACH")" in this chart for more information.
Press "POOL/SPA" control button to select thermostat.	The "Pool" or "Spa" indicator light specifies which thermostat is currently being used.
Press "Up" or "Down" control button to select desired temperature.	<ul style="list-style-type: none"> • The "Desired Temp" indicator light illuminates. • The thermostat's temperature setting raises or lowers 1-degree per button key press. The thermostat can be adjustable from a minimum of 45° F to a maximum of 104°F. Please note - Setting the temperature below 45°F turns the thermostat off.
Wait 15-seconds to allow heat pump to exit programming mode.	<ul style="list-style-type: none"> • The "water temp" light turns on and the current water temperature is displayed. • If the desired water temperature is different than the current water temperature, the heat pump fan will activate. After a four minute time delay the heat pump's compressor will activate and the heating or cooling light will illuminate depending on the operating mode selected.
Selecting Celsius or Fahrenheit	
Press and hold "Up" and "Down" buttons simultaneously.	"CF1" (Celsius / Fahrenheit) code appears.
Press "Up" or "Down" button to select codes "0" or "1".	Code "0" = Temperature displays in Celsius. Code "1" = Temperature displays in Fahrenheit.
Wait 15-seconds to allow heat pump to exit programming mode.	

STEPS	EXPLANATION
Enabling Lockout Option	
Press and hold "Up" and "Down" buttons simultaneously until "CF1" is displayed.	If "LOC" is briefly displayed, followed by a "0", the heat pump is already locked. A numerical password is required to proceed. See "Unlocking Heat Pump" on page 5 for more information.
Press "Pool/Spa" button until "ELC" is displayed.	Any prior password can be viewed from this program.
Press "Up" button once to view any existing numerical password.	
if desired, press "Up or "Down" button to change or add a numerical password	The password can be any number from "00" to "99". Without knowledge of the correct password, control adjustments will not be possible.
Press "Pool/Spa" Button to lock in the password.	
Press "Pool/Spa" button until "ULC" is displayed.	
Press "Up" button till "1" is displayed.	Code "0" = User Lock disabled. Code "1" = User Lock enabled.
Press "Pool/Spa" Button to save selection.	
Wait 15-seconds to allow heat pump to exit programming mode.	The heat pump lock-out feature is now enabled and the heat pump itself is locked. Any future changes will now require a numerical password.
Unlocking Heat Pump	
Press "Up" or "Down" Button.	If the heat pump is locked, "LOC" is briefly displayed followed by a "0", prompting the entry of the correct password.
Press "Up" button to enter the password.	
Press "Pool/Spa" Button.	If the correct password has been entered, the heat pump is unlocked. The current water temperature is displayed and control settings are available.
	<ul style="list-style-type: none"> • The heat pump locks after being left idle for 15-seconds or after changing a program option. • Before changing multiple program options it is recommended that the lockout option be disabled. The lockout option can be re-enabled after all changes are completed
Disabling Lockout Option	
Press and hold "Up" and "Down" buttons simultaneously until "CF1" is displayed.	
Press "Pool/Spa" button until "ULC" is displayed	
Press "Down" button until "0" is displayed.	Code "0" = User Lock disabled. Code "1" = User Lock enabled.
Wait 15-seconds to allow heat pump to exit programming mode.	All programmable features are now available.

Table 4

2.2 Heating Water

- 1) Heat pump's mode is set to "HEA".
- 2) Thermostat is set to desired water temperature.
- 3) Water pump's time clock is overridden to 24-hour operation. This is only necessary for an initial startup. After the water reaches the desired temperature, the time clock can be reset to a normal time frame operation.
- 4) Sufficient time is provided for heat pump to operate. The following calculations determine how long it will take the heat pump to bring the water to temperature. The calculation is only an approximation and varies per site condition. Additional heat pump runtime is needed to compensate for cooling factors such as waterfalls, disappearing edges, fountains, etc.

HEATING TIME FORMULAS

1) POUNDS OF WATER								
<input style="width: 100%;" type="text"/> Length of Pool	X	<input style="width: 100%;" type="text"/> Width of Pool	X	<input style="width: 100%;" type="text"/> X 7.5 Gallons per Cubic Feet	X	<input style="width: 100%;" type="text"/> X 8.3 = <input style="width: 100%;" type="text"/> Pounds per Gallon Total Pounds of Water to Heat		
2) REQUIRED BTU'S								
		<input style="width: 100%;" type="text"/> Desired Temp	-	<input style="width: 100%;" type="text"/> Current Temp of Water	X	<input style="width: 100%;" type="text"/> = <input style="width: 100%;" type="text"/> Total Pounds of Water to Heat BTUs Required		
3) NUMBER OF HOURS								
				<input style="width: 100%;" type="text"/> BTUs Required	÷	<input style="width: 100%;" type="text"/> BTU Output of Heat pump	=	<input style="width: 100%;" type="text"/> Total Hours Required to Heat Water

Figure 2

2.3 Cooling Water

- 1) Heat pump's mode is set to "COO".
- 2) Thermostat is set to desired water temperature.
- 3) Water pump's time clock is overridden to 24-hour operation. After the water reaches the desired temperature, the time clock can be reset to a normal time frame operation.
- 4) Sufficient time is provided for heat pump to operate.

COOLING TIME FORMULAS

1) POUNDS OF WATER								
<input style="width: 100%;" type="text"/> Length of Pool	X	<input style="width: 100%;" type="text"/> Width of Pool	X	<input style="width: 100%;" type="text"/> X 7.5 Gallons per Cubic Feet	X	<input style="width: 100%;" type="text"/> X 8.3 = <input style="width: 100%;" type="text"/> Pounds per Gallon Total Pounds of Water to Cool		
2) REQUIRED BTU'S								
		<input style="width: 100%;" type="text"/> Current Temp of Water	-	<input style="width: 100%;" type="text"/> Desired Temp	X	<input style="width: 100%;" type="text"/> = <input style="width: 100%;" type="text"/> Total Pounds of Water to Heat BTUs Required		
3) NUMBER OF HOURS								
				<input style="width: 100%;" type="text"/> BTUs Required	÷	<input style="width: 100%;" type="text"/> 370,000 BTU Output of Heat pump	=	<input style="width: 100%;" type="text"/> Total Hours Required to Cool Water

Figure 3

2.4 Heat Pump's Defrost Operation



WARNING - Failure to heed the following may result in injury or death.
ROTATING FAN PROP HAZARD: fan may start during defrost cycle. Keep hands clear of fan blade at all times.

Frost can form on the heat pump evaporator coil under certain weather conditions. When enough frost has formed to inhibit heat pump operation, the heat pump starts a defrost cycle.

- 1) "FS" is displayed on the LED display
- 2) The heat pump cycles through 50-minutes of heating and 10-minutes of hot-gas defrost. A moderate amount of frost can form on the air coil during the 50-minute heating period. Steam can be seen coming off the evaporator during the 10-minutes of hot-gas defrost.
- 3) The fan operation is suspended during the 10-minute cycle permitting maximum heating of the air-coil. However, if discharge pressure rises the fan will continue to operate.

SECTION 3 - MAINTENANCE



WARNING - Failure to heed the following may result in injury or death. Possible electric shock hazard - Disconnect power to all electrical devices on pad when washing heat pump. Do not restore electrical power until equipment is completely dry.



CAUTION - Failure to heed the following may result in equipment damage. Do not use a pressure cleaner to wash heat pump. Damage to heat pump components, such as the heat pump's evaporator fins, will result. If using a hose-end spray nozzle adjust spray pattern to low strength only.

3.1 Cleaning Equipment

Clean and polish heat pump frequently to prevent damage to equipment. More frequent service is required for heat pumps located in sandy or coastal areas; where sand and salt spray can become detrimental factors to equipment.

Washing

- 1) Remove upper access panel. (the panel that does not contain the control pad)
- 2) Being careful not to bend the evaporator's fins, wash both sides of the evaporator coil and outside cabinet using a low pressure water hose. Brush any debris inside the cabinet towards the open access panel and remove from heat pump.
- 3) While the heat pump is still wet, use an approved cleaning agent and pump spray bottle to coat the exterior of the heat pump.
- 4) Avoiding the evaporator fins, use a detergent-dampened cloth to wipe the heat pump's exterior cabinet.
- 5) Flush all exterior surfaces and both sides of evaporator coil with fresh water using a low pressure water hose.
- 6) Again avoiding the evaporator fins, dry exterior cabinet using a soft cloth. Allow evaporator coil to air dry.
- 7) Confirm equipment pad is dry, and being sure not to over tighten screws, re-install access panel.

Polishing

- 1) Do not touch, or otherwise attempt to polish the evaporator. Polish the heat pump's cabinet panels using an approved polishing agent and following the manufacturer's instructions.
- 2) Rinse the heat pump panels with fresh water and wipe and buff panels using a dry soft cloth.
- 3) Allow heat pump interior and surrounding equipment to "air-dry" for several hours prior to restoring electrical power.

APPROVED CLEANING AGENTS
Fantastic
409
All Power Plain Detergent (3% solution)
Cascade (preferred if also cleaning the evaporator)
APPROVED POLISHING AGENTS
Simoniz Wax
Aero Wax
Glo-Coat
Armorall Protectant (for use on cabinet surfaces only; do NOT apply to evaporator).

Table 5

3.2 Monitoring Conditions

3.2.a Pool Chemistry



CAUTION - Failure to heed the following may result in equipment damage. Stop water flow when refinishing or acid washing pool. Failure to follow these instructions may damage equipment and voids heat pump warranty.



CAUTION - Failure to heed the following may result in equipment damage. To avoid damage to equipment, monitor and maintain chemistry within recommended levels.

Check water chemistry regularly and maintain within recommended levels as shown in Table 6. Standards for commercial applications vary in different areas. Follow all local applicable codes.

CHEMICAL	POOLS	SPAS
Chlorine	1.0 – 3.0 ppm	1.5 – 3.0 ppm
Bromine	2.0 – 4.0 ppm	3.0 – 5.0 ppm
pH	7.4 – 7.6 ppm	7.2 – 7.8 ppm
Total Alkalinity	80 – 140 ppm	80 – 120 ppm
Calcium Hardness	200 – 400 ppm	200 – 400 ppm
Total Dissolved Solids	1,000 – 2,000 ppm	1,500 ppm above start-up TDS in spas

Table 6

3.2.b Clearances

Maintain airflow clearances around heat pump for maximum product efficiency. See section entitled “Positioning Clearances” on page 14 for more information.

3.2.c Water Flow

Water flow through the heat pump may be reduced to a point where internal safety devices will shut off the heat pump (i.e.: “HP” or “HP5”). Maintain equipment as outlined below to prevent water flow issues:

- Operate water filtration devices per manufacturer's specifications. Dirty filters can cause reduced water flow to the heat pump. The higher the pressure on the filter gauge, the lower the flow rate.
- Keep baskets free of debris. Similar to a dirty filter, large amounts of debris in the pump and skimmer baskets can reduce water flow..
- Check for improper valve settings. A partially closed valve after the filter, or a full-open bypass around the heat pump, will cause insufficient water flow through heat pump.

3.2.d Irrigation and Storm Run-Off

Irrigation water spray can damage heat pump components. Regardless of water quality, it is important that irrigation be directed away from the heat pump. Prevent rainwater runoff from pouring directly into the heat pump. The heat pump is designed to withstand normal rainfall, but solid streams of water from roof drip-lines may eventually damage heat pump components. If the heat pump resides beneath a roof edge a rain leader (gutter) or rain shield is required.

3.4 Winterizing



CAUTION - Failure to heed the following may result in equipment damage.

- Failure to properly winterize heat pump may result in serious equipment damage. Freeze damage is not covered under the heat pump warranty.
- While the plumbing connections are in the winterized condition (not fully tightened), it is imperative pool/spa water not be circulated through the heat pump. Loss of water through loose plumbing connections may result in damage to circulating pump, pool/spa structure, and/or other equipment.

There are two freeze conditions requiring heat pump attention. A light-freeze is when ambient air temperature falls below 32 degrees Fahrenheit for less than 8 hours. A hard-freeze is when ambient air temperature falls below 32 degrees Fahrenheit for 8 or more hours.

Light-Freeze Conditions

Typically during light-freeze conditions circulating (moving) water will not freeze. Override time clocks and allow filtration system to run continuously during light-freeze conditions. In areas where freezing conditions are prevalent and sustained, the heat pump **MUST** be winterized for hard freeze conditions.

Hard-Freeze Conditions

- 1) Disconnect all electrical power to heat pump; turn “OFF” water circulation pump.
- 2) Disconnect the plumbing to the heat pump at connection unions, (removal is counter-clockwise).
- 3) Wait until water has completely drained from equipment. Expect to see a lot of water drain out at first, and then a small amount to continue to drain out over a long period.
- 4) After heat pump is fully drained, partially reconnect plumbing connection unions. (This prevents insects and vermin from entering the plumbing during the winterized period and still allows condensation to drain from the heat pump.)
- 5) When ready to use heat pump again, hand-tighten connection unions.

3.5 Preventive Maintenance



WARNING - Failure to heed the following may result in injury or death.

Annual inspection and service must be performed by a qualified pool and heat pump specialist in order to prevent physical injury or damage to equipment.

An annual inspection and maintenance program is strongly recommended starting one (1) year after installation of heat pump. See Figure 4 for recommended inspection checklist. AquaCal AutoPilot can perform this service in limited areas. Contact Customer Support for more information.

Preventive Maintenance 20-Point Checklist

<input checked="" type="checkbox"/>	Check Water Flow	<input checked="" type="checkbox"/>	Oil Fan Motor (As Applicable)
<input checked="" type="checkbox"/>	Clean Evaporator Coil	<input checked="" type="checkbox"/>	Check Fan Motor Amperage Draw
<input checked="" type="checkbox"/>	Check Relay Contacts	<input checked="" type="checkbox"/>	Check Pool & Spa Water Chemistry
<input checked="" type="checkbox"/>	Check Capacitor Values	<input checked="" type="checkbox"/>	Check and Clean Condensate Drains
<input checked="" type="checkbox"/>	Check Refrigerant Levels	<input checked="" type="checkbox"/>	Check Compressor Amperage Draw
<input checked="" type="checkbox"/>	Clean Heat Pump Cabinet	<input checked="" type="checkbox"/>	Check Water Pump Amperage Draw
<input checked="" type="checkbox"/>	Check Fan Blade Clearances	<input checked="" type="checkbox"/>	Acid Wash Source Coil (As Applicable)
<input checked="" type="checkbox"/>	Check Flow/Pressure Switch	<input checked="" type="checkbox"/>	Check Air Temperature Change Through Evaporator
<input checked="" type="checkbox"/>	Check Electrical Connections	<input checked="" type="checkbox"/>	Check Operating Controls and Temperature Sensors
<input checked="" type="checkbox"/>	Check Proper Voltage To Unit	<input checked="" type="checkbox"/>	Check Water Temperature Change Through Condenser

Figure 4

SECTION 4 - INSTALLATION

⚠ WARNING - Failure to heed the following may result in injury or death. Installation of this equipment by anyone other than a qualified installer can result in a safety hazard. The information contained throughout the “Installation” section is intended for use by qualified heat pump installation technicians, familiar with the swimming pool/spa service industry safety standards and methods.

⚠ CAUTION - Failure to heed the following may result in equipment damage. Failure to properly protect equipment against corrosive environments or atmospheres will adversely affect the life of the equipment and will void equipment warranty.

4.1 Equipment Specifications

4.1.a General

Electrical Service	See installation section entitled “Wiring” on page 21.
Water Flow Requirements	140-280 GPM
Weight	1550 POUNDS

Table 7

4.1.b Unit Dimensions

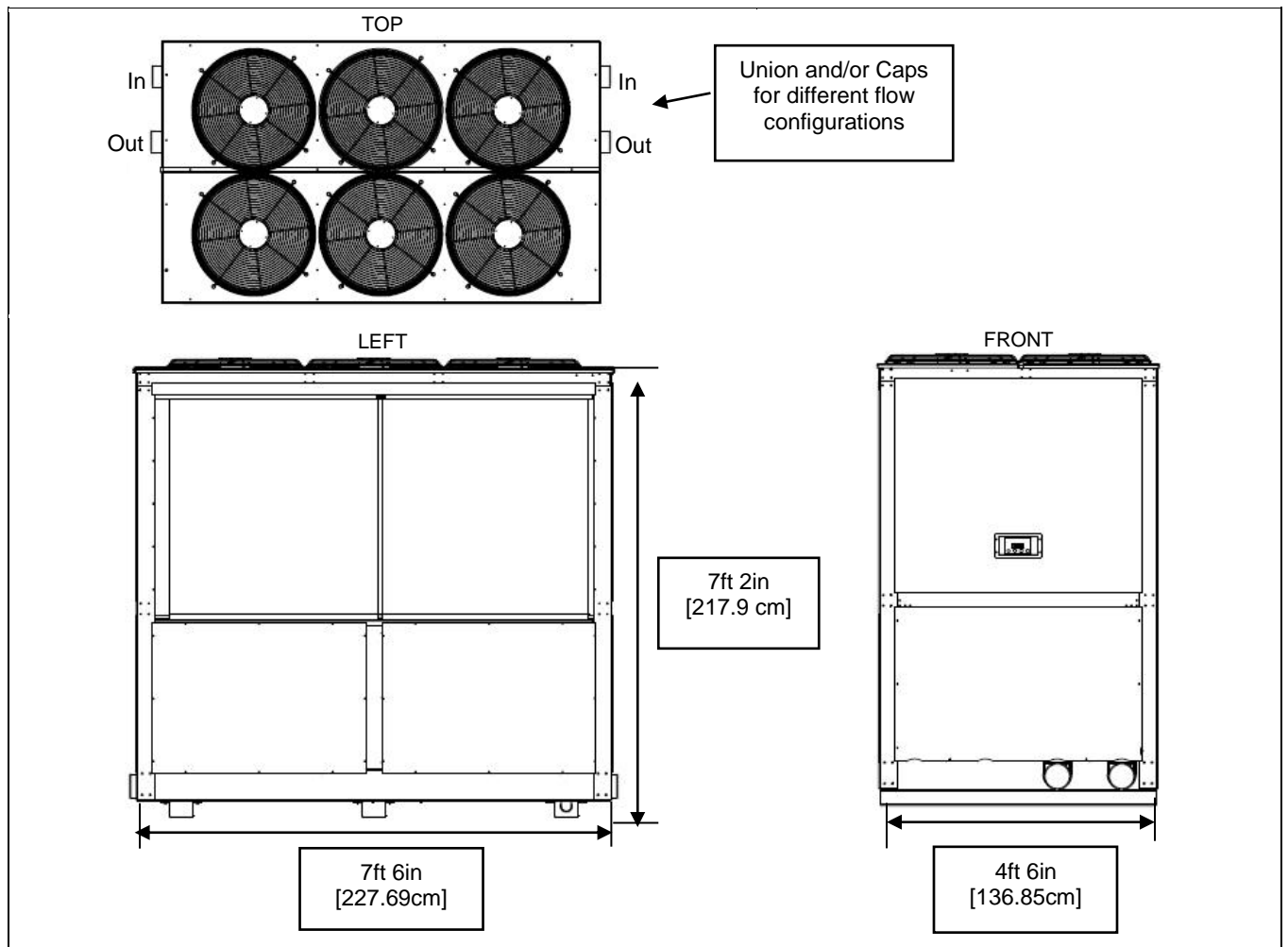

Figure 5

4.1.c Access Panels

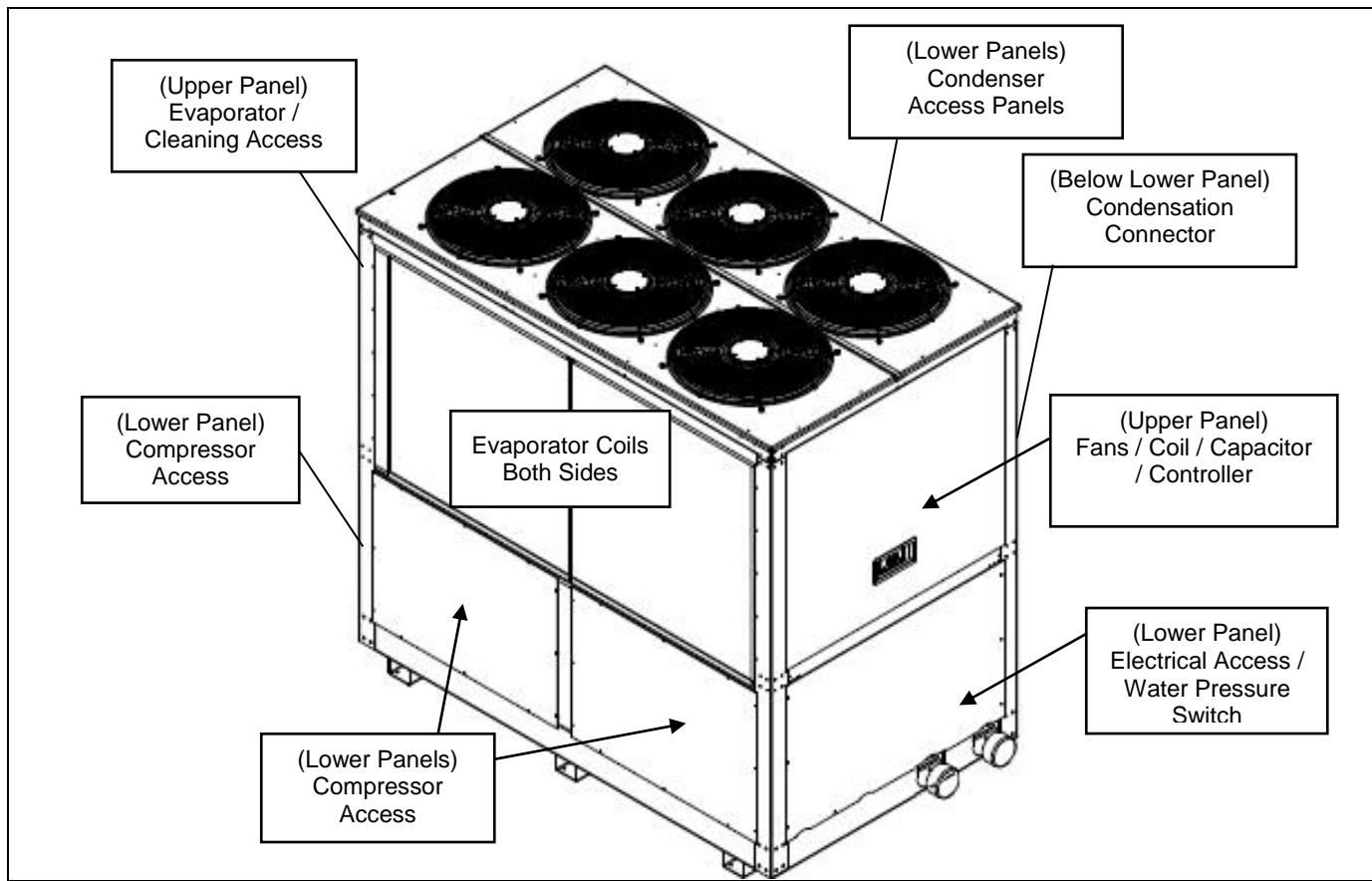

Figure 6

4.2 Placing Heat Pump

4.2.a Indoor versus Outdoor Installation

Outdoor heat pump installations are recommended. Indoor installations require specialized airflow controls and can be problematic. If no viable alternative exists, contact the AquaCal AutoPilot Engineering department for assistance prior to proceeding with an indoor installation.

4.2.b Positioning Clearances

Air flow clearances of three (3) feet on each side must be maintained for maximum efficiency of heat pump. Overhangs must be a minimum of ten (10) feet above equipment.

- Keep area immediately adjacent to heat pump clear of shrubs and bushes, lawn furniture, chemical containers, etc. These items prevent air from circulating fully through heat pump and result in inefficient and damaging heat pump operation. Proper clearances also provide service and maintenance personnel access to working parts of the heat pump.
- Do not block air from exiting the heat pump by place objects on top of the heat pump. Damage to the compressor and fan motor will result.
- Follow all applicable local, state, and national requirements relative to spacing from other objects or equipment.

4.2.c Controlling Irrigation and Rainwater Runoff

Avoid placing heat pump in direct rainwater runoff from roofs. If the roof slope directs runoff into the heat pump, a gutter or rain shield is required on the roof edge above the heat pump. Avoid water spraying onto the heat pump by re-locating or adjusting irrigation.

4.2.d Planning for Condensation

The heat pump can produce a large amount of condensation. This condensation must be directed away from the heat pump and disposed of according to local code requirements. A hose connection for this purpose is located below the lower access panel.

4.2.e Mounting Pad Requirements

The equipment pad is to be constructed of concrete, or other code-approved materials sufficient to support the weight of the heat pump. The equipment pad must meet all requirements of authorities having code-related jurisdiction.

The pad is to be elevated and placed to provide adequate drainage and support to the base of the heat pump.

The pad is to be essentially level and extend in all directions (at least) 6" beyond the base of the heat pump. Under no circumstances should the heat pump be installed directly onto the earth.

4.2.f Anchoring Heat Pump to Pad

Follow all relevant local, state, or national requirements regarding wind load anchoring. When anchoring is required, use AquaCal AutoPilot optional Hurricane Anchoring Kits.

AquaCal AutoPilot anchoring kits satisfy the very stringent Florida Building Code Section 301.13: Wind Anchoring Requirements. Contact AquaCal AutoPilot to obtain the correct anchoring kit for the heat pump being installed. Please have the heat pump model number ready when contacting AquaCal AutoPilot Parts Group.

As necessary, contact the AquaCal AutoPilot Technical Support Group for assistance in determining best method of compliance.

4.3 Plumbing



CAUTION - Failure to heed the following may result in equipment damage. Water flow exceeding 280-GPM may damage titanium condenser; such damage will not be covered under the equipment warranty. Install a bypass valve whenever water flow rate may exceed 280-GPM. Contact AquaCal AutoPilot Technical Support for guidance regarding testing for water flow rate.

Plumbing diagrams are provided in this section as a planning guide to the sequence of equipment, valves, fittings, etc. The basic plumbing configurations for typical installations are shown for both U-Flow and Z-Flow collection headers. For connection to pool water supply and return, each unit is shipped with 4" PVC fittings: 2 unions; 2 caps; and 4 couplings.

The heat pump must receive water flow within the specified minimum and maximum ranges. If the installation does not closely follow any of the supplied plumbing diagrams, AquaCal AutoPilot Technical Support is available for installation advice and guidance.

4.3.b Plumbing Diagrams

**PLUMBING EXAMPLE 1
(U-FLOW COLLECTION HEADER)**

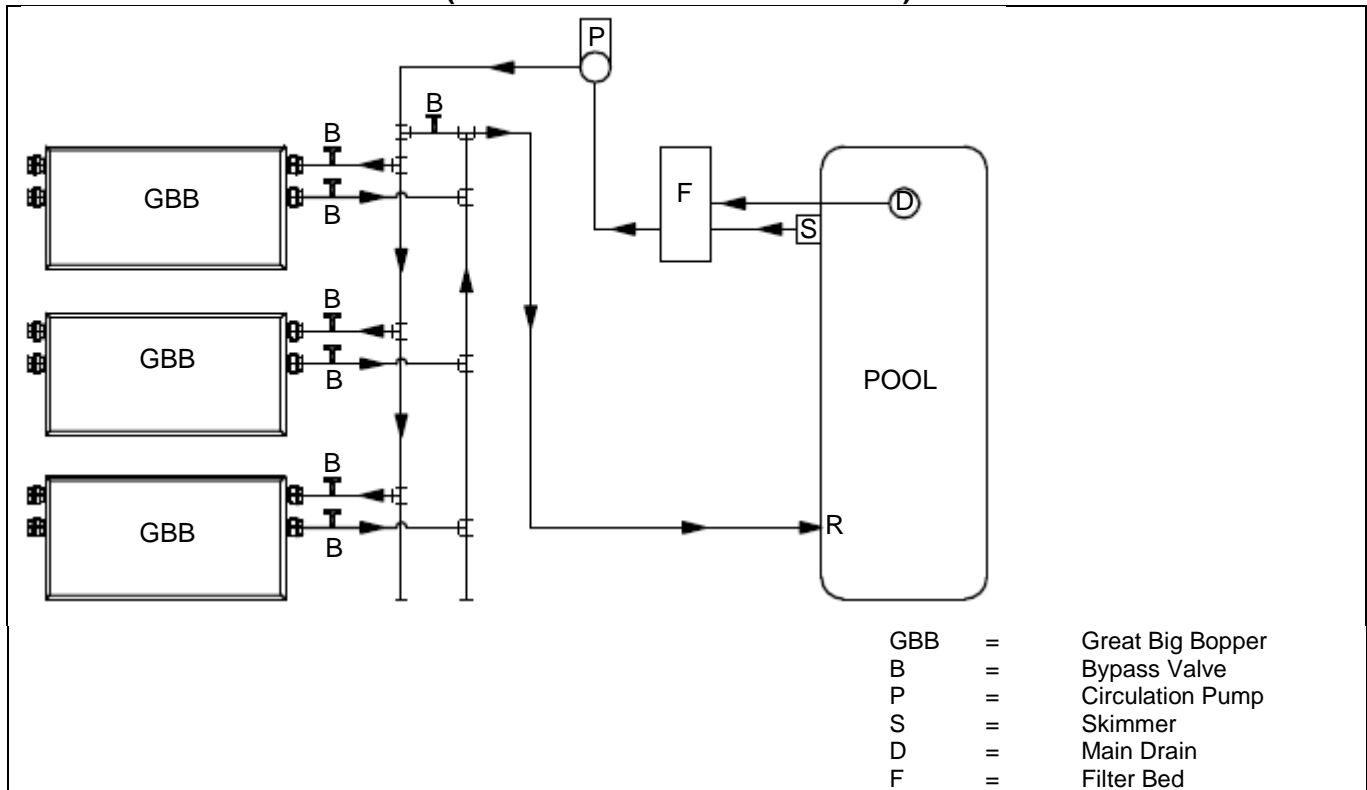

Figure 7

**PLUMBING EXAMPLE 2
(U-FLOW COLLECTION HEADER)**

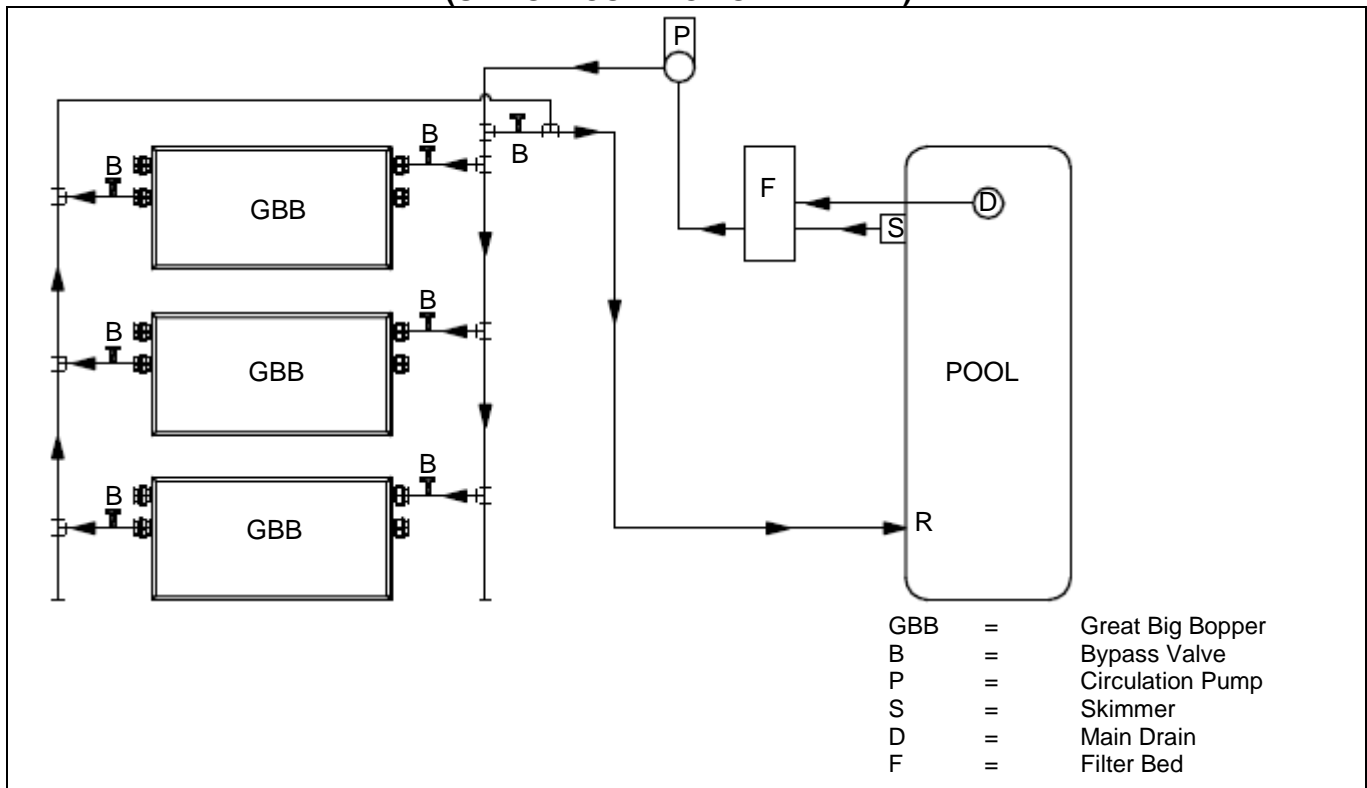

Figure 8

**PLUMBING EXAMPLE 3
(Z-FLOW COLLECTION HEADER)**

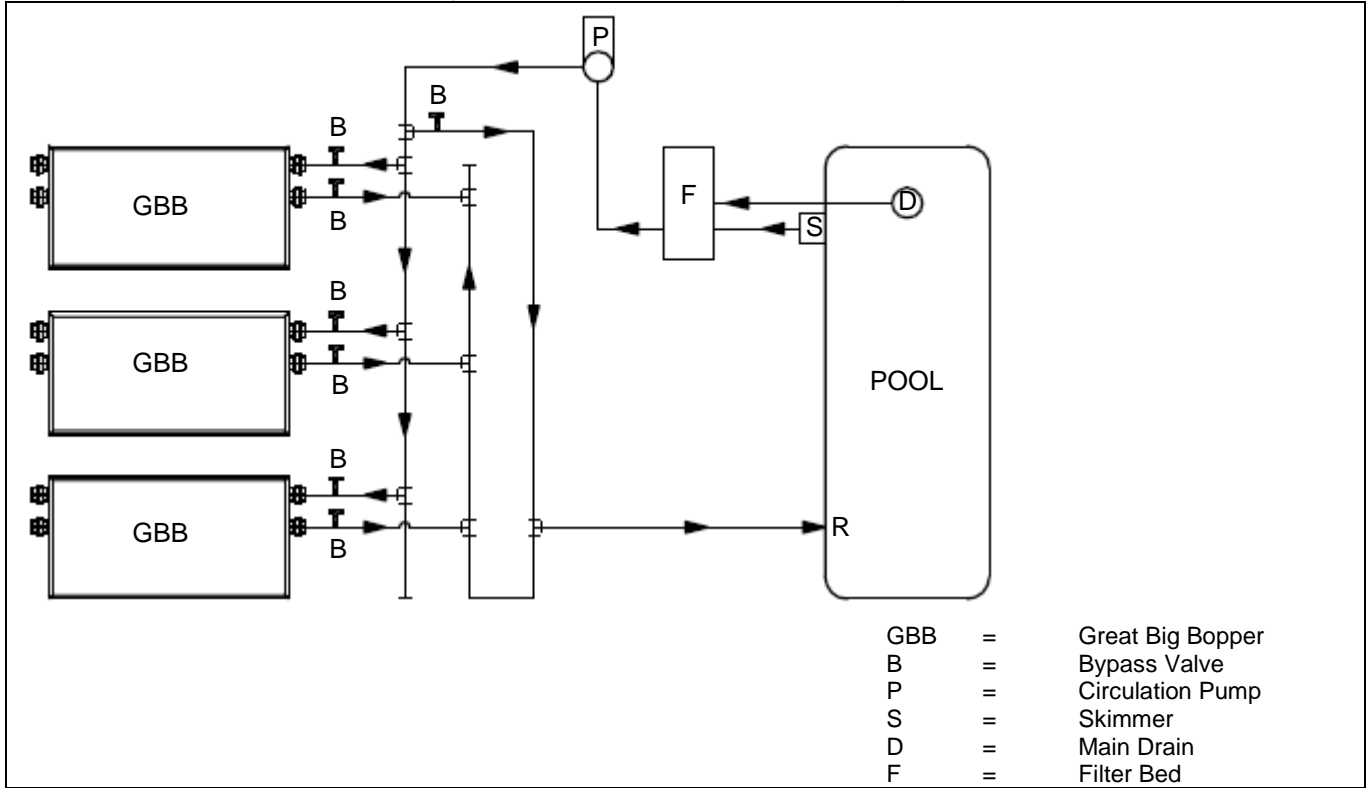

Figure 9

**PLUMBING EXAMPLE 4
(Z-FLOW COLLECTION HEADER)**

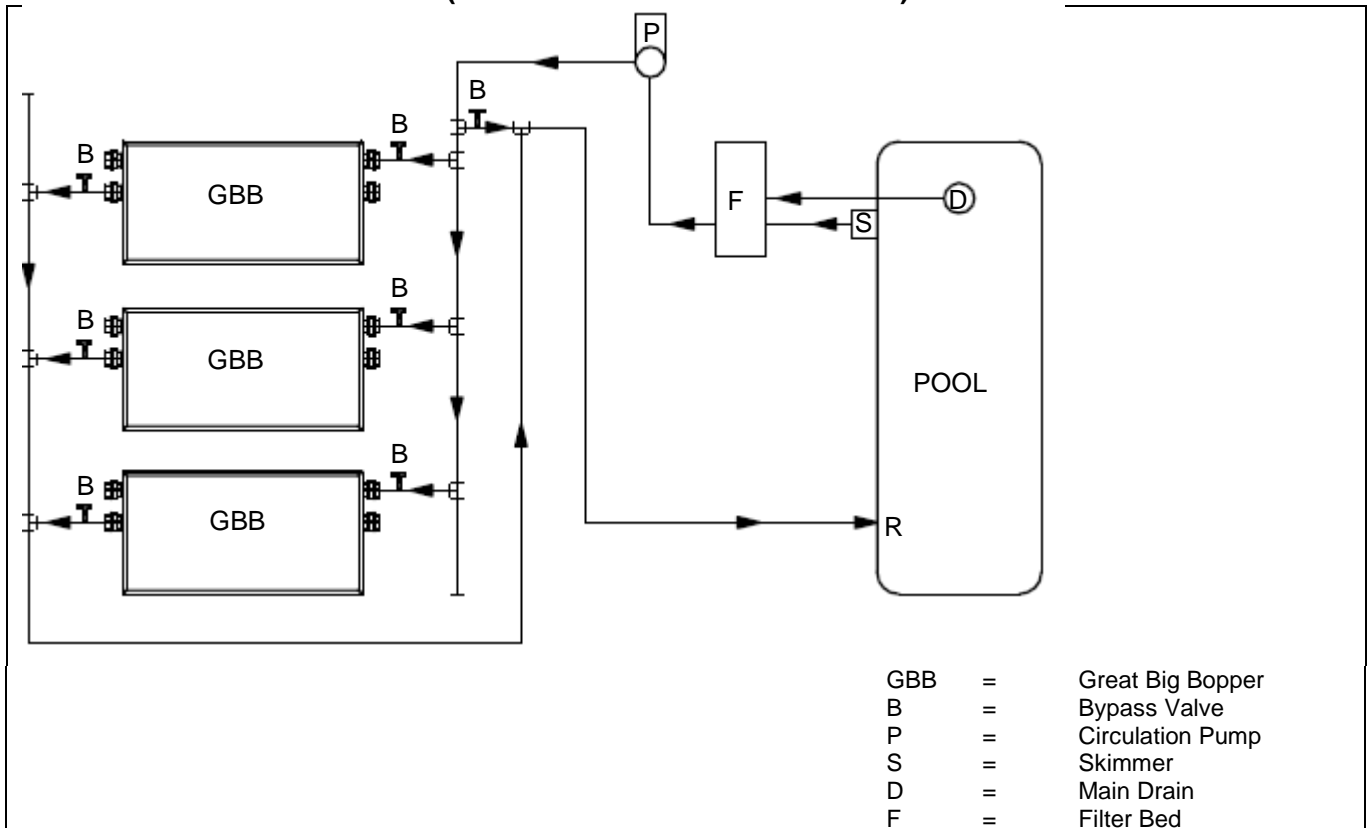

Figure 10

DO NOT PLUMB AS SHOWN HERE

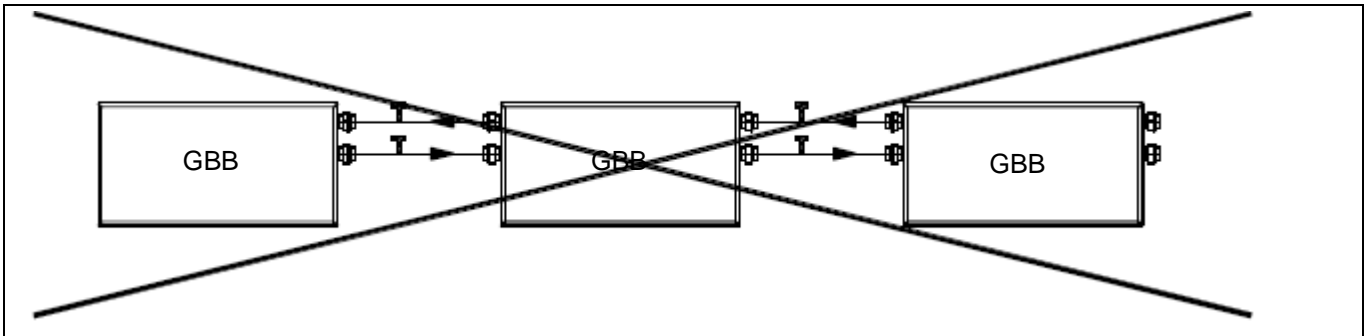

Figure 11

4.3.c In-Line Chlorine Feeders

Always place in-line chlorinators as low, and as far downstream from the heat pump as possible. If an erosion type feeder is used, always install a Hartford Loop to protect internal heat pump components.

4.3.d Water Connections to Heat Pump

The Great Big Bopper is supplied with 4" PVC plumbing unions. Connection to site plumbing is made via PVC solvent cement to the female slip socket of the plumbing unions.

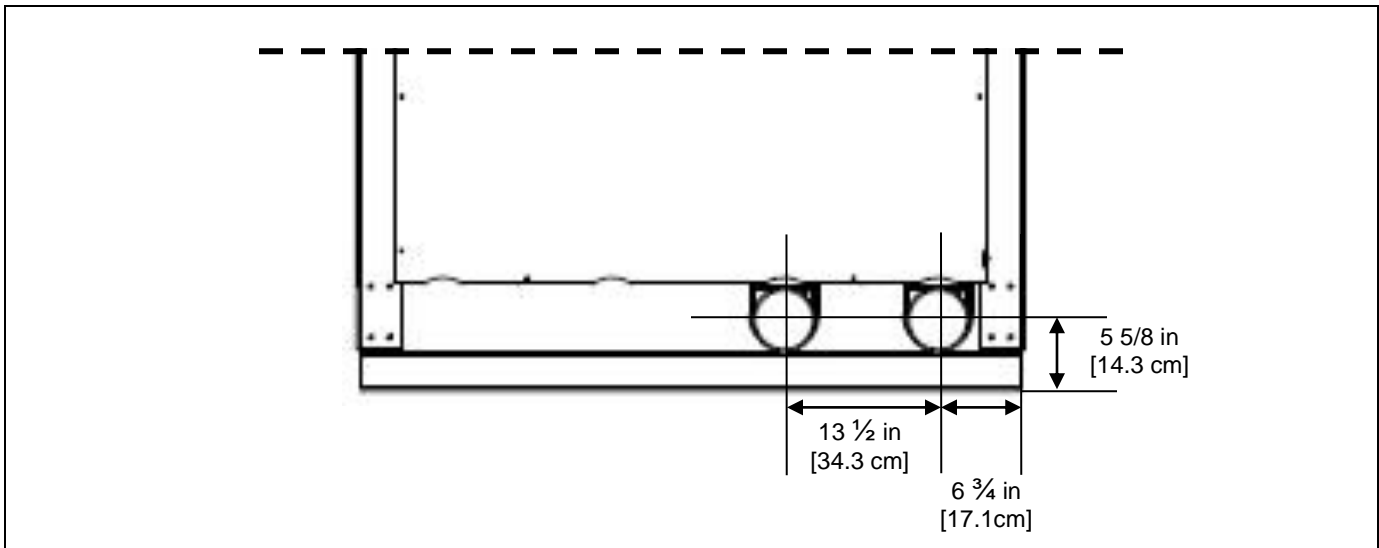

Figure 12

4.3.f *Maintaining Ability to Winterize*



- CAUTION** - Failure to heed the following may result in equipment damage.
Do not use glue on the threaded portion of the equipment's unions. A glued-in-place union will prevent the Great Big Bopper from being properly winterized.

The unions allow for easy disconnection and re-connection of the heat pump from/to the plumbing system during hard freeze conditions. Do not defeat the function of the unions by using glue on the threaded portion of the unions.

4.3.g *Water Flow Rates and Operating Pressures*



- CAUTION** - Failure to heed the following may result in equipment damage.
Water flow exceeding 280-GPM may damage titanium condenser; such damage will NOT be covered under the equipment warranty. Install a bypass valve whenever water flow rate may exceed 280-GPM. Contact AquaCal AutoPilot Technical Support for guidance regarding testing for water flow rate. The maximum static (or operating pressure) is 50 pounds-per-square-inch (PSI).

The Great Big Bopper heat pump is designed to operate with a flow rate of 200-280 gallons-per-minute (GPM). Design the plumbing system to maintain at least 200-GPM flow through the heat pump under worst case conditions (i.e.: filter fouled to 10 PSI rise). These specifications relate to the heat pump only. Code-specified whole system turnover rates must be satisfied.

4.3.h *Water Flow (Pressure) Switch Adjustment*



- WARNING** - Failure to heed the following may result in injury or death.
Water Pressure Switch adjustment procedure to be performed by experienced service personnel only; procedure must not be attempted by individuals lacking adequate electrical and mechanical experience.



- WARNING** - Failure to heed the following may result in injury or death.
Beware of ROTATING FAN PROP HAZARD. Fan may start during water switch adjustment. Keep hands clear of fan blade at all times.



- CAUTION** - Failure to heed the following may result in equipment damage.
If, after water pressure switch adjustment, the heat pump continues to operate with water pump off, readjust water pressure switch to ensure heat pump will not run without water flow.

If the heat pump abnormally turns on without water flow, a water pressure switch adjustment may be required. Confirm the following before attempting a water pressure switch adjustment:

- Water circulator pump is operating.
- Filter is clean.
- Water valves are set to flow water through the heat pump.
- "FLO" code is displayed (or displays intermittently).

Locate Water Pressure Switch:

- Remove heat pump access plate (lower panel - below the control panel access plate)
- Locate water pressure switch. The switch will be found attached outside of the electrical enclosure, at lower edge; exact location will vary by heat pump model.
- Identify type of switch to adjust ("Len Gordon" or "TecMark"). To determine which brand pressure switch is installed see Figure 13 and Figure 14. Follow the adjustment procedure for the appropriate switch.

- Should adjustment of water pressure switch prove unsuccessful, contact AquaCal AutoPilot Technical Support; site-specific factors may require the installation of an external flow switch.

“Len Gordon” Switch:

- 1) Locate black rectangular plastic tab, located on forward-facing side of the switch. See Figure 13. The black rectangle is a wheel lock tab.
- 2) Slide tab left to unlock the adjustment wheel.
- 3) With water pump operating and electrical power supplied to the heat pump, slowly rotate top of adjustment wheel towards you until “FLO” code (just) disappears.
- 4) Once adjustment has been completed, slide wheel locking tab fully back to right-hand locked position.
- 5) With electrical power remaining “ON” and heat pump operating, shut off power to circulating pump. If switch has been correctly adjusted, heat pump will shut off and “FLO” code will display when water pump stops.
- 6) Reinstall heat pump front cover.

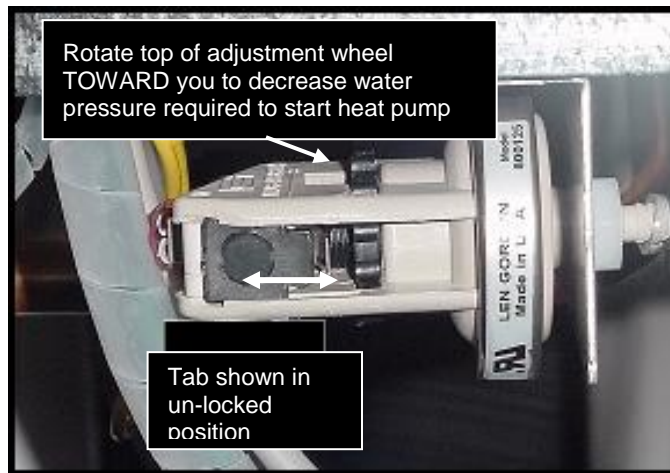

Figure 13

“TecMark” Switch:

- 1) TecMark switches do not have an adjustment wheel lock. See Figure 14.
- 2) With water pump operating, and electrical power supplied to heat pump, slowly rotate top of adjustment wheel away from you until “FLO” code (just) disappears.
- 3) With electrical power remaining “ON” to heat pump and heat pump operating, shut off power to circulating pump. If switch has been correctly adjusted, when water pump stops, heat pump will shut off and “FLO” code will display.
- 4) Reinstall heat pump front cover.



Figure 14

4.3.i Installations with In-floor Cleaning Systems

Where a cycling cleaning system is installed, AquaCal AutoPilot strongly recommends a water hammer suppression standpipe assembly within the plumbing circuit. For additional information, please contact AquaCal AutoPilot Customer Support.

4.4 Wiring



WARNING - Failure to heed the following may result in injury or death. The information contained in this section is intended for use by qualified electrical installation technicians, familiar with electrical service industry safety standards and methods.

4.4.a Standards

STANDARDS ¹	TITLE
Article 440	Standard for Safety for Electric Spas, Equipment Assemblies, and Associated Equipment.
Article 680	Standard for Safety for Swimming Pool Pumps, Filters and Chlorinators.
IEC 60335-1-2001	Household and similar electrical appliances - Safety - General requirements
IEC 60335-2-40 2006	Household and similar electrical appliances - Safety – Particular requirements for electrical heat pumps, air-conditioners and dehumidifiers.
NFPA 70	The electrical installation must conform to the current version of the NEC, and all applicable local and state codes.
UL1995	Heating and cooling equipment.

Table 8

4.4.b General Requirements

- Locate the equipment disconnect within 3-feet of the heat pump’s electrical enclosure, or as close to the heat pump as possible. Always satisfy applicable codes and standards.
- AquaCal AutoPilot heat pumps are designed for copper conductors, only. Do not use aluminum wire.
- Never mount a power-disconnect directly to the heat pump.
- In sizing power wiring, be especially aware of up-sizing requirements necessary due to wiring distances. Always satisfy applicable codes and standards.
- Multiple heat pumps installed at the same site generally require special automatic sequencing controllers to avoid excessive power drops at start-up. An “ASC” controller is available by calling AquaCal AutoPilot Customer Support. See “Available Accessories” on page 37 for more information.

4.4.c Grounding and Bonding

Follow local code requirements for properly grounding and bonding heat pump equipment.

4.4.d Sizing the Electrical Service

There are two (2) identical data plates on the heat pump; one located on the outside right front corner and one behind the front access panel of electrical enclosure. Refer to equipment data plate (for Figure 15) for specific information required to size electrical service and over-current protection of heat pump. Sizing is based on data plate information, wire size, wiring devices, and over-current protection per applicable local codes and standards.

¹ Not all standards are applicable in all installations. Follow all local applicable codes.

Data Plate Example

MINIMUM CIRCUIT AMPACITY	<input type="text"/>	MADE IN THE USA
ELEC. SERVICE: VOLTS	<input type="text"/>	PH <input type="text"/> HZ <input type="text"/>
MAXIMUM TIME DELAY FUSE OR HACR BREAKER	<input type="text"/>	
COMPRESSOR VOLTS	<input type="text"/>	R.L.A. <input type="text"/> L.R.A. <input type="text"/>
FAN MOTOR VOLTS	<input type="text"/>	H.P. <input type="text"/> F.L.A. <input type="text"/>
REFRIGERANT: Circuit 1 - Factory charged	<input type="text"/>	Only oz/Kg <input type="text"/>
REFRIGERANT: Circuit 2 - Factory charged	<input type="text"/>	Only oz/Kg <input type="text"/>
Tested to	<input type="text"/> psig High side /	<input type="text"/> psig Low side
OUTDOOR USE		
<p>AQUA CAL, INC A TEAM HORNER COMPANY 2737 24TH STREET NORTH ST. PETERSBURG, FL 33713 FACTORY SERVICE 727-823-5642</p>	MODEL NUMBER	<input type="text"/>
	IIIBAR CODEIII	
	SERIAL NUMBER	<input type="text"/>
	IIIBAR CODEIII	

Figure 15

4.4.e Ground-Fault Protection

Local codes and regulations may require the use of a ground fault interruption device (GFI Circuit Breaker). Nuisance tripping of these devices is common and not covered under the terms of the Manufacturer's warranty.

4.4.f External Controls / Equipment

The Great Big Bopper allows external equipment to control the heat pumps "ON" / "OFF" functionality. A direct connection for external controllers has been provided on the microprocessor board.

- 1) Connect the external controller to the terminal block of the microprocessor board using at least 18-gauge low voltage.
- 2) For a two-wire controller (which has a thermostat) – Connect to the "Y" and "Z" connections of the block labeled "X-Y-Z". See Figure 16.
- 3) For a three-wire controller (which does not have a thermostat) – Connect to the block labeled "FS-2".
- 4) Program the heat pump to accept an external controller's signal. See section entitled "Configuring for External Controller" on page 25 for more information.

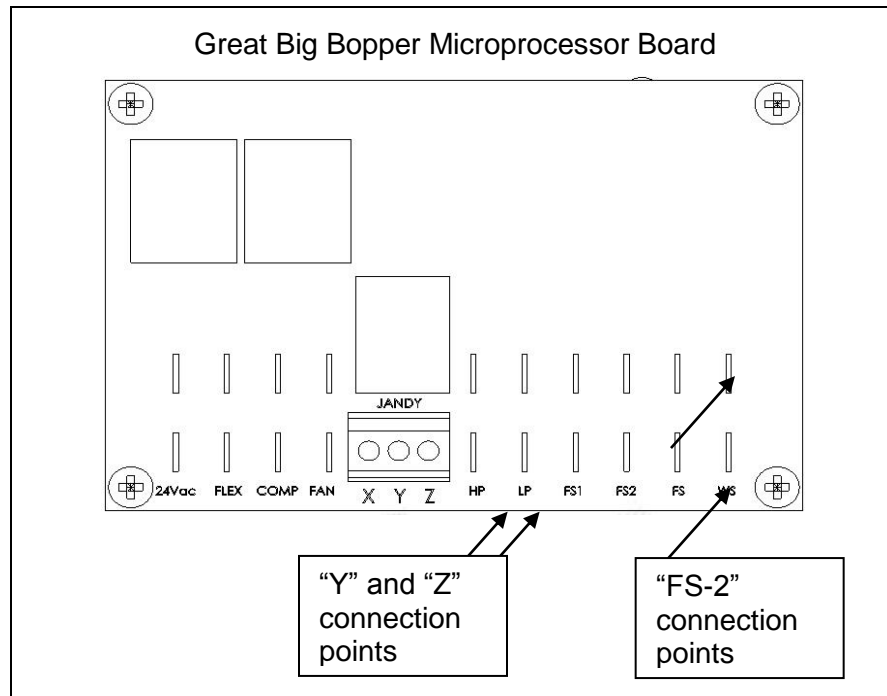

Figure 16

4.4.g Positioning Mode Jumper



WARNING - Failure to heed the following may result in injury or death. Risk of Electrical Shock- Ensure all electrical power to the heat pump has been disconnected prior to removing the heat pump front access panel. Leave electrical power disconnected throughout the following jumper repositioning procedure.



CAUTION - Failure to heed the following may result in equipment damage. This is NOT an owner or operator procedure. Repairs must not be attempted by untrained and/or unqualified individuals.

Default Position

The position of a jumper on the heat pump's microprocessor is set for "Heat-Cool". Altering this jumper setting will cause the heat pump to lose controller functionality and is not recommended. If needed, the heat pump jumper can be verified and repositioned.

Verifying Position

1. Apply electrical power to heat pump.
2. Review the available modes by repeatedly pressing the "MODE" button:
 - Heat only models display "OFF" and "HEA".
 - Heat-Cool models display "OFF", "HEA", "COO", and "AHC".
3. If the modes do not display correctly the jumper is placed in the wrong position.

Repositioning as Needed

- 1) Disconnect electrical power.
- 2) Unscrew control panel from front upper access panel. Gently twist and push control panel into hole in access panel.
- 3) Remove heat pump's upper front access panel.
- 4) Unscrew control panel assembly and gain access to control board.
- 5) Remove and reposition jumper located at the upper right hand corner of control board. See Figure 17. Jumper must cover middle and lower pin as shown for "Heat and Cool".

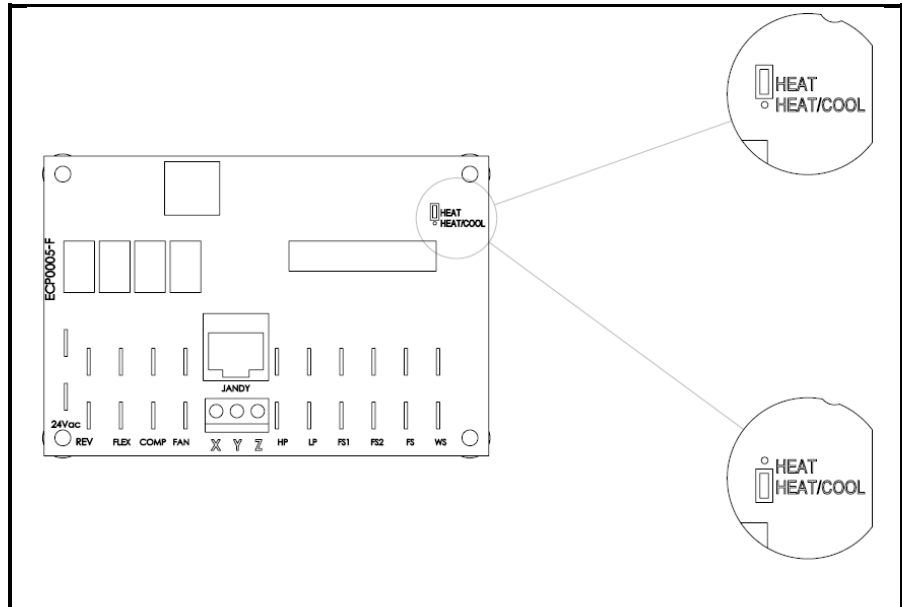

Figure 17

4.5 Programming



CAUTION - Failure to heed the following may result in equipment damage.

- Service Level Programming must only be attempted by authorized service centers. If adjustments are deemed necessary, contact installing dealer or AquaCal AutoPilot Customer Support. Un-authorized adjustments in the Service Menu (beyond the “LOC” menu) will void factory warranty.
- The time delay should only be de-activated for diagnostic convenience, and must be re-activated prior to placing heat pump back in service. Failure to reset time delay could result in permanent damage to the heat pump compressor.
- Using the back door entry will reset all settings to factory default; including any installer entered configuration. See section entitled “Re-Setting Heat Pump (“Back Door” Entry)” on page 27 for more information. Re-entry of all custom site condition settings will be required when using this re-set.

The heat pump allows for two levels of programming; User-level and Service-level programming. This section describes programming for site specific conditions in the Service-level programming.

The installer must insure the programming is compatible with any external controllers and confirm heat pump starts and operates per manufacturer’s specifications. Unless instructed by AquaCal AutoPilot Technical Support Group, the installer should not adjust sensor calibration or dead-band values.

4.5.a Program Displays

MESSAGE	DESCRIPTION
"CF1"	Select water temperature format; in either Celsius or Fahrenheit.
"ULC"	Enable heat pump lock out feature.
"ELC"	Select password to lock out heat pump access.
"LOC"	Access to site-dependent setup parameters. Factory code required. (Not intended for use by the owner)
"FS2"	Configure remote flow switch or automatic thermostat switch connected to heat pump.
"JAO"	Configure an external controller connected to the heat pump.
"dEL"	Deactivate time delay.
"tSC"	Calibrate water sensor.
"dSC"	Calibrate defrost sensor.
"dBS"	Adjust number of degrees water temperature must fall below set point before spa thermostat closes and calls for heat or cooling. (Dead Band Spa)
"dBP"	Adjust number of degrees water temperature must fall below set point before pool thermostat closes and calls for heat or cooling. (Dead Band Pool)

4.5.b Service Level Programs

STEPS	EXPLANATION
Entering Service Menu	
Press and hold "Up" and "Down" buttons simultaneously.	"CF1" code appears.
Press "Pool/Spa" button until "LOC" is displayed.	This is the entrance point for the Service Menu.
Use "Up" or "Down" button to enter factory access passcode.	The factory default code is "0".
Press the "Pool/Spa" button once.	Service level programs are now available. If left idle for 15-seconds, program will time-out and exit programming mode.
Deactivating Time Delay	
The time delay should only be de-activated by qualified HVAC technicians for diagnostic convenience, and must be re-activated prior to placing heat pump back in service. Failure to reset time delay feature could result in permanent damage to heat pump compressor.	
Enter Service Menu	If needed, see "Entering Service Menu" in this chart.
Press the "Pool/Spa" button until "dEL" is displayed.	This is the entrance point for the Time Delay Menu.
Press "Up" or "Down" button to select "0" or "1".	Select "0" to disable time delay. Select "1" to allow time delay to remain active.
Wait 15-seconds to allow heat pump to exit programming mode.	Configuration is complete.
Configuring for External Controller	
Enter Service Menu	If needed, see "Entering Service Menu" in this chart.
Press the "Pool/Spa" button until "JAO" is displayed.	This is the entrance point for the External Controller Interface.
Press the "Up" or "Down" button to select "0" or "1".	Select "0" for no external controller. Select "2" for two wire controller. Select "3" for three wire controller.
Wait 15-seconds to allow heat pump to exit programming mode.	Configuration is complete.

STEPS	EXPLANATION
Configuring for Remote Flow Switch	
It is assumed that a remote flow switch has been connected to the heat pump.	See "Connecting External Controllers" on page 37 for more information.
Enter Service Menu	If needed, see "Entering Service Menu" in this chart.
Press the "Pool/Spa" button until "FS2" is displayed.	This is the entrance point for the External Controller Interface.
Press the "Up" or "Down" button to select "0" or "1".	Select "0" for no switch. Select "1" to enable switch.
Wait 15-seconds to allow heat pump to exit programming mode.	Configuration is complete.
Calibrating Water Sensor	
If it is believed the displayed temperature does not match the actual temperature, follow the steps below to verify and adjust the controller as necessary. Be certain to use an accurate thermometer.	
Obtain an accurate water temperature reading.	<ul style="list-style-type: none"> • With circulating pump in operation and water moving through heat pump, place a reliable thermometer in water. Making sure to measurement water away from returns, determine the temperature of the water entering the heat pump. • Once measured, compare the water temperature to heat pump displayed water temperature. • If temperatures within 1°F, no calibration is necessary. • If temperature differs by 2° to 3°F, calibration is necessary. Proceed to next step.
Enter Service Menu	If needed, see "Entering Service Menu" in this chart.
Press the "Pool/Spa" button until "tSC" is displayed.	This is the entrance point for the water sensor calibration.
Press the "Up" or "Down" button to match the measure water temperature.	<ul style="list-style-type: none"> • The controller can be adjusted to plus or minus 10°F from the nominal displayed temperature. • Offset calibrations greater than 3°F should be avoided. Such large offsets generally indicate problems with either the method of water temperature measurement, a water sensor not properly inserted into the well, or other equipment issues. Do NOT attempt to mask such issues through offset calibration.
Wait 15-seconds to allow heat pump to exit programming mode.	Calibration is complete.
Calibrating Defrost Sensor	
Follow steps below to verify and adjust defrost operation.	
Press "MODE" Button until operating mode shows "OFF".	
Obtain an accurate temperature reading at suction line.	<ul style="list-style-type: none"> • Remove the heat pump front panel to gain access to the defrost sensor location. • Position a clamp-on, thermocouple-type temperature sensor onto the suction line; position the clamp immediately adjacent to the defrost sensor. • Connect the clamp-on thermocouple to a multi-meter designed to accept the input of the clamp-on device.
Allow heat pump to remain OFF for a minimum of 10-minutes.	
Enter Service Menu	If needed, see "Entering Service Menu" in this chart.
Press "Pool/Spa" button until "dSC" is displayed.	This is the entrance point for the defrost sensor calibration.

STEPS	EXPLANATION
Press "Up" or "Down" button once to display the current temperature value of the defrost sensor.	Compare controllers displayed defrost sensor temperature against reading obtained by clamp-on device. <ul style="list-style-type: none"> • If the defrost temperatures is within 1°F, no calibration is necessary. • If the temperatures differ by 2° to 3°F, calibration is necessary, proceed to next step.
Press "Up" or "Down" button to match temperature reading obtained by clamp-on device.	<ul style="list-style-type: none"> • The controller can be adjusted to plus or minus 10°F from the nominal displayed temperature. Please note - offset calibrations greater than 3°F, however, should be avoided. Such large offsets generally indicate problems with the method of defrost temperature measurement, a defrost sensor not properly attached to the suction line, or other equipment issues. Do NOT attempt to mask such issues through offset calibration.
Wait 15-seconds to allow heat pump to exit programming mode.	Front panel can be re-attached. Calibration is complete.
Set system controls to desired mode of operation.	If needed, see "Setting Operating Mode" on page 4.
Adjusting Dead Band Differential	
The dead band differential determines the number of degrees the water temperature must rise or fall below the set point before calling for heating or cooling. Unless instructed by AquaCal AutoPilot Technical Support Group, the installer <u>should not</u> adjust sensor calibration or dead-band values. The steps below outline the procedure.	
Enter Service Menu	If needed, see "Entering Service Menu" in this chart.
Press "Pool/Spa" button until "dBS" is displayed for Spa or "dBP" is displayed for Pool.	This is the entrance point for the Dead-band Differential adjustment menu.
Press "Up" button once to display current setting.	
Press "Up" or "Down" button to adjust differential in 1-degree increments.	The differential is adjustable in 1-degree increments from 1 to 5-degrees Fahrenheit. <ul style="list-style-type: none"> 1 degree = .5 degree above or .5 degrees below water temperature. 2 degree = 1 degree above or 1 degree below water temperature. 3 degree = 1.5 degree above or 1.5 degrees below water temperature, etc.
Wait 15-seconds to allow heat pump to exit programming mode.	Calibration is complete.
Re-Setting Heat Pump ("Back Door" Entry)	
The factory "Back Door Entry" will reset the service lock code back to the factory setting "50".	
Simultaneously Press "Pool/Spa" button and "Up" button until display shows "888". Release buttons.	CAUTION - Using this option will RESET ALL SETTINGS TO THE FACTORY DEFAULTS. This includes external controller configuration and will require re-entry of any site condition settings. See "Microprocessor Default Parameters" for a complete list of factory default parameters on page 28.

Table 9

4.5.d Default Program Parameters

The following options have been pre-programmed into the microprocessor.

CODE	DESCRIPTION	DEFAULT VALUE	RANGE
"CFI"	Celsius/Fahrenheit Selection.	1	0 = Celsius / 1 = Fahrenheit
"CFO"	Call Flex Options	0	This option is not used.
"dBP"	Pool Dead Band Differential	1°	1° TO 5°
"dBS"	Spa Dead Band Differential	1°	1° TO 5°
"dEL"	Time Delay	1	0 = "OFF" 1 = "ON"
"dSC"	Defrost Sensor Calibration	Factory Calibrated	Plus or minus 10°F
"ELC"	Enter Lock Code	50	00 - 99
"FS2"	Flow Switch / Auto T-Stat Switching Option	0	0 = "No Switch" 1 = "Enable Switch"
"JAO"	External Controller	0	0 = "No Controller" 2 = "Two Wire Controller" 3 = "Three Wire Controller"
"LOC"	Service Entry Point	50	00 - 99
"tSC"	Water Sensor Calibration	Factory Calibrated	Plus or minus 10°F
"ULC"	User Lock Code	0	0 = "User Lockout Disabled" 1 = "User Lockout Enabled"
	Operating Mode	"OFF"	Heat Only – "OFF" / "HEA" Heat and Cool – "OFF", "HEA", "COO", and ACH"
	Thermostat Settings (Pool and Spa)	"OFF"	

Table 10

4.6 Optional Installation

4.6.a Pool and Spa Combination Heating

The heat pump comes equipped with two thermostats; one for pool and one for spa. The water is maintained at the selected thermostat set point depending on the correct setting of the water isolation valves.



Pool / spa installations can be automated with an "External Flow Switch". This option changes the selector thermostat each time the pool or spa isolation valve is positioned. See "Available Accessories" on page 37 for more information.

4.6.b Spa Heating Setback Option

Turn off air blowers when heating a spa to prevent added heat loss and increasing required run time to heat spas.

When using heat pump to heat a spa only, the "POOL" thermostat can be used as a setback control: Set the "POOL" thermostat at a point 10-15° F below desired spa heat temperature and select the pool thermostat. This method allows the spa to be held at a heated temperature, but somewhat lower than normal spa-use temperatures. Using spa setback will result in reduced warm up periods over full cold starts. Use a spa cover when using this setback method.

SECTION 5 - TROUBLESHOOTING

-  **WARNING** - Failure to heed the following may result in injury or death. Repairs must not be attempted by untrained unqualified individuals. If service is deemed necessary, contact installing dealer or AquaCal AutoPilot Customer Support.
-  **WARNING** - Failure to heed the following may result in injury or death. Heat pump contains refrigerant under high pressure. Repairs to refrigerant circuit must not be attempted by untrained or unqualified individuals. Service must be performed only by qualified HVAC technicians. Recover refrigerant before opening system.
-  **CAUTION** - Failure to heed the following may result in equipment damage. Service by un-authorized personnel will void factory warranty.

5.1 Symptom / Resolution Charts

Please note – Troubleshooting charts are for Main Controller version 3.0.

SYMPTOM	RULE OUT	RESOLUTION
<i>Control Panel Not Working</i>		
	An external controller is being used	STEP 1: See section entitled “Connecting External Controller” on page 37 for more information on heat pump controller functionality when using external controllers.
		STEP 2: Call heat pump installer or AquaCal AutoPilot Customer Support for further assistance.
<i>Heat Pump Not Running</i>		
	No power to heat pump	STEP 1: Confirm heat pump display is illuminated. <ul style="list-style-type: none"> • If not, then confirm the main breaker (located at the power supply panel) and the disconnect switch (located near the heat pump) are both turned ON. • If yes, proceed to next step.
	Incorrect mode setting	STEP 2: Confirm correct mode is selected. See “Setting Operating Mode” on page 4. If heat pump still does not turn on, proceed to next step.
	Thermostat set incorrectly	STEP 3: Confirm that thermostat is set above / below ambient air temperature depending on mode setting. See “Setting Thermostats” on page 4. If heat pump still does not turn on, proceed to next step.
	Error displayed	STEP 5: If an error code is displayed, see appropriate fault code in this section. If no fault code is displayed, proceed to next step.

SYMPTOM	RULE OUT	RESOLUTION
	External controller being used	<p>STEP 6:</p> <ul style="list-style-type: none"> If an external controller is being used, confirm heat pump is set to accept the controller's signal. See section entitled "External Controls / Equipment" on page 22 and "Configuring for External Controller" on page 25 for more information. If heat pump is set correctly to accept an external controller's signal, then contact the installer of the external controller device or the device's manufacturer for further assistance.
		<p>STEP 7:</p> <p>Call heat pump installer or AquaCal AutoPilot Customer Support for further assistance.</p>
Heat Pump Running, Not Heating		
	Heat pump not moving heat	<p>STEP 1:</p> <p>Measure temperature of discharge air coming out of the top of the heat pump. If the discharge air is between 9° to 12° F colder than the ambient air temperature, then the heat pump <u>is</u> moving heat.</p>
	Incorrect mode setting	<p>STEP 2:</p> <p>Confirm heat pump mode is set to either "HEA" OR "ACH". See "Setting Operating Mode" on page 4 for more information.</p>
	Incorrect thermostat setting	<p>STEP 3:</p> <p>Confirm thermostat is set above the ambient air temperature. See "Setting Thermostats" on page 4 for more information.</p>
	External controller being used	<p>STEP 4:</p> <ul style="list-style-type: none"> If an external controller is being used, confirm heat pump is set to accept the controller's signal. See section entitled "External Controls / Equipment" on page 22 and "Configuring for External Controller" on page 25 for more information. If heat pump is set correctly to accept an external controller's signal, then contact the installer of the external controller device or the device's manufacturer for further assistance.
	Error condition exists	<p>STEP 5:</p> <p>If an error code is displayed, see appropriate fault code in this section. If no fault code is displayed, proceed to next step.</p>
	Heating wrong body of water	<p>STEP 6:</p> <p>Confirm valves are correctly positioned to heat correct body of water. If heating a spa that overflows into a pool, confirm the spa is isolated when being heated.</p>
	Insufficient run time	<p>See heating time formulas in section entitled "Heating Water" on page 6 for more information.</p>
	Water not retaining heat	<p>STEP 8:</p> <p>If heating a spa, turn off water jets to allow for quicker heating times. For pools, turn off water effects, such as slides, waterfalls, or fountains to allow water to retain heat more efficiently. Use of a liquid pool blanket product, such as "HeatsavrTM", can also compensate for excessive heat loss.</p>
		<p>STEP 9:</p> <p>Call heat pump installer or AquaCal AutoPilot Customer Support for further assistance.</p>

SYMPTOM	RULE OUT	RESOLUTION
Heat Pump Tripping Breaker		
	Weak breaker	<p>STEP 1: If breakers do not trip immediately, then issue is most likely a weak breaker. Have an electrician confirm breakers are in good condition and properly sized for heat pump.</p>
	Incorrect heat pump power sequence	<p>STEP 2: Multiple heat pumps installed at the same site require special automatic sequencing controllers to avoid excessive power drops at start-up. Call heat pump installer or AquaCal AutoPilot Customer Support for further assistance on this type of equipment. See "Automatic Sequencing Controller" in "Available Accessories" on page 37 for more information.</p>
	Faulty compressor	<p>STEP 3:</p> <ul style="list-style-type: none"> • With heat pump off, open access panels to view compressors. Turn on power to each heat pump and monitor as each compressors starts. They will power on in stages. Determine if breaker trips as a compressor turns on. • If fault occurs when a compressor turns on, service will be required to determine compressor issue and why compressor has failed. PLEASE NOTE – compressor failure is extremely rare. Compressor failure must be determined before compressor replacement is considered. Call heat pump installer or AquaCal AutoPilot Customer Support for further assistance on this type of repair.
Heat Pump Won't Shut Off		
	External controller being used improperly	<p>STEP 1:</p> <ul style="list-style-type: none"> • If an external controller is being used, confirm heat pump is set to accept the controller's signal. See section entitled "External Controls / Equipment" on page 22 and "Configuring for External Controller" on page 25 for more information. • Determine if external controller has its own thermostats. If yes, then heat pump mode must be set to "OFF". • If heat pump is set correctly to accept an external controller's signal to turn off, then contact the installer of the external controller device or the device's manufacturer for further assistance.
	Incorrect mode setting	<p>STEP 2: Confirm the heat pump mode is set to "OFF". See "Setting Operating Mode" on page 4 for more information.</p>
		<p>STEP 3: Call heat pump installer or AquaCal AutoPilot Customer Support for further assistance.</p>
Heat Pump Running, Not Cooling		
	Heat pump not moving heat out	<p>STEP 1: Measure the temperature of the discharge air coming out of the top of the heat pump. If the discharge air is between 9° to 12° F warmer than the ambient air temperature, then the heat pump <u>is</u> moving heat out of the water.</p>

SYMPTOM	RULE OUT	RESOLUTION
	Incorrect mode setting	STEP 2: Confirm the heat pump mode is set to either "COO" OR "ACH". See "Setting Operating Mode" on page 4 for more information.
	Incorrect thermostat setting	STEP 3: Confirm the thermostat is set below the ambient air temperature. See "Setting Thermostats" on page 4 for more information.
	An external controller is being used improperly	STEP 4: <ul style="list-style-type: none"> • If an external controller is being used, confirm heat pump is set to accept the controller's signal. See section entitled "External Controls / Equipment" on page 22 and "Configuring for External Controller" on page 25 for more information. • If heat pump is set correctly to accept an external controller's signal, then contact the installer of the external controller device or the device's manufacturer for further assistance.
	Error condition exists	STEP 5: If an error code is displayed, see appropriate fault code in this section. If no fault code is displayed, proceed to next step.
	Cooling wrong body of water	STEP 6: Confirm valves are correctly positioned to cool the correct body of water.
	Insufficient run time	STEP 7: Confirm the water pump is being run long enough to allow the heat pump to cool the water. See "Heating Water" on page 6 for more information.
		STEP 8: Call heat pump installer or AquaCal AutoPilot Customer Support for further assistance.
Water Coming From Heat Pump		
	Determine if water is from a leak or condensate	STEP 1: If using chlorine or bromine as a pool/spa sanitizer, use a test strip in water at heat pump to determine if sanitizer is present. If sanitizer is present, a leak may exist.
		STEP 2: Turn off heat pump, leaving water pump on. After several hours, determine if water is still coming from heat pump. If water is still coming from heat pump, then a leak may be present.
		STEP 3: Call heat pump installer or AquaCal AutoPilot Customer Support for further assistance.

Table 11

5.2 Fault Code Definitions

FAULT CODE	RULE OUT	RESOLUTION
<i>“dPO” Indicator</i>		
Defrost sensor is open	Cut or loose sensor wiring.	Defrost sensor requires replacement.
<i>“PO” Indicator</i>		
Water temperature sensor is open	Cut or loose sensor wiring.	Water temperature sensor requires replacement.
<i>“dPC” Indicator</i>		
Defrost sensor is shorted	Short circuit in the defrost sensor wiring or defective sensor.	Defrost sensor requires replacement.
<i>“PC” Indicator</i>		
Water temperature sensor is shorted	Short circuit in water sensor wiring or defective sensor.	Water temperature sensor requires replacement.
<i>“HP” Indicator</i>		
Refrigerant system’s high-pressure switch is open.	Low water flow.	STEP 1: See resolution for “FLO” Indicator. If error re-occurs, proceed to next step.
	Defective high-pressure switch or wiring.	STEP 2: Identify which refrigerant circuit is causing fault. Replace high-pressure switch for that circuit. If error re-occurs, proceed to next step.
	High refrigerant charge.	STEP 3: A qualified HVAC technician should confirm coolant charge is correct for both refrigerant circuits. See heat pump data plate for correct charge and verify charge. Please note – improperly charging the system can void manufacturer’s warranty.
<i>“HP5” Indicator</i>		
Heat Pump has locked out due to five (5) HP (high-pressure) faults during one call for heating or cooling.	Low water flow.	STEP 1: See resolution for “FLO” Indicator. Then re-set heat pump by turning power off, then back on. If error re-occurs, proceed to next step.
	Defective high-pressure switch or wiring.	STEP 2: Identify which refrigerant circuit is causing fault. Replace high-pressure switch for that circuit. If error re-occurs, proceed to next step.
	High refrigerant charge.	STEP 3: A qualified HVAC technician should confirm coolant charge is correct for both refrigerant circuits. See heat pump data plate for correct charge and verify charge. Please note – improperly charging the system can void manufacturer’s warranty.

FAULT CODE	RULE OUT	RESOLUTION
“LP” Indicator		
Refrigerant system’s low-pressure switch is open.	Defective low-pressure switch or wiring.	STEP 1: Identify which refrigerant circuit is causing fault. Replace high-pressure switch for that circuit. If error re-occurs, proceed to next step.
	Low refrigerant charge.	STEP 2: A qualified HVAC technician should confirm coolant charge is correct for both refrigerant circuits. See heat pump data plate for correct charge and verify charge. Please note – improperly charging the system can void manufacturer’s warranty.
		STEP 3: Call heat pump installer or AquaCal AutoPilot Customer Support for further assistance.
“LP5” Indicator		
Heat Pump has locked out due to five (5) LP (low-pressure) faults during one call for heating or cooling.	Defective low-pressure switch or wiring.	STEP 1: Identify which refrigerant circuit is causing fault. Replace high-pressure switch for that circuit. Then re-set heat pump by turning power off, then back on. If error re-occurs, proceed to next step. If error re-occurs, proceed to next step.
	Low refrigerant charge.	STEP 2: A qualified HVAC technician should confirm coolant charge is correct for both refrigerant circuits. See heat pump data plate for correct charge and verify charge. Please note – improperly charging the system can void manufacturer’s warranty.
		STEP 3: Call heat pump installer or AquaCal AutoPilot Customer Support for further assistance.
“OtA” Indicator		
Water temperature exceeded 110°F The unit locked out due to an over temperature alarm. It will not be reset until the water sensor drops to 100°F or lower.	Improper usage of other heating equipment	STEP 1: Determine if another heat pump (gas heater, solar heater, etc.) is heating water being sent directly to Great Big Bopper. This situation will need to be corrected before continuing to use Great Big Bopper.
	Incorrect reading from water temperature sensor.	STEP 2: Verify existing water temperature with an <u>accurate</u> external meter. If Great Big Bopper’s sensor is inaccurate, water temperature sensor requires replacement. If error re-occurs, proceed to next step.
		STEP 3: Call heat pump installer or AquaCal AutoPilot Customer Support for further assistance.
“FLO” Indicator		
Low or no water flow detected.	Water pump off or on too low a speed.	STEP 1: Confirm water pump on. Run at high speed to determine if error persists. If error re-occurs, proceed to next step.
	Valves in incorrect position.	STEP 2: Confirm water is not being diverted away from Great Big Bopper, or insufficient water balance exists. If error re-occurs, proceed to next step.

FAULT CODE	RULE OUT	RESOLUTION
		STEP 3: Call heat pump installer or AquaCal AutoPilot Customer Support for further assistance.
<i>“FS” Indicator</i>		
Heat pump in defrost mode.		This is a normal operation of heat pump. See “Heat Pump” on page 7 for more information.
<i>“CSE” Indicator</i>		
Control system error.	Defective control board.	STEP 1: Disconnect then reconnect power to reset control. If error re-occurs, proceed to next step.
		STEP 2: Control board requires replacement. If error re-occurs, proceed to next step.
		STEP 3: Call heat pump installer or AquaCal AutoPilot Customer Support for further assistance.
<i>“CEr” Indicator</i>		
Communication fault.	Loose or damaged cable	STEP 1: Check “Cat5” cable from control board to display assembly.
		STEP 2: Call heat pump installer or AquaCal AutoPilot Customer Support for further assistance.

Table 12

SECTION 6 - APPENDIX

6.1 Available Accessories

NAME	PART #	DESCRIPTION
EXTERNAL FLOW SWITCH KIT	0040S	<ul style="list-style-type: none"> Used for automatic pool/spa thermostat switching Use when the pool/spa elevation is higher than the heat pump. When using two-speed circulation pumps (and low-speed water pressure will not properly activate heat pump water pressure switch)
AUTOMATIC SEQUENCING CONTROLLER	ASC-2 (2 heat pumps) ASC-3 (3 heat pumps) ASC-4 (4 heat pumps) ASC-5 (5 heat pumps) ASC-6 (6 heat pumps) ASC-7 (7 heat pumps) ASC-8 (8 heat pumps) ASC-9 (9 heat pumps) ASC-10 (10 heat pumps)	An Automatic Sequencing Controller (ASC) prevents simultaneous startup of multiple heat pumps. Site voltage drop is minimized and utilities are not subjected to large in-rush demands of electrical current.
REMOTE CONTROLLER	STK0070	External microprocessor kit allows for full control of the heat pump from up to 100 feet from the equipment.

Table 13

6.2 Schematics

- “LTM0214” - model BB500 - 200-230 VAC, 60 Hz or 480 VAC, 60 Hz.
- “LTM0215” - model BB500 - 380-415 VAC, 50 Hz.

6.3 Connecting External Controllers

- “LTP0050” - connecting 2-wire and 3-wire external controllers.